

Stemin Machinefabriek b.v.  
Hanzeweg 3 • 7241 CR Lochem  
P.O. Box 32 • 7240 AA Lochem  
The Netherlands  
T (+) 31 (0) 573 25 20 43  
F (+) 31 (0) 573 25 71 13  
info@stemin.nl • www.stemin.nl



## VEBOFLEX-N



Inhaltsverzeichnis

Table of Contents

Beschreibung		Description	3 / 4
Sicherheitsfaktoren		Safety Factors	5 / 6
Wahl der Kupplung		Coupling Selection	7
Nennleistungen		Nominal Power Ratings	8
Technische Daten		Technical Data	9
Abmessungen	Standard <b>N</b> Standard	Dimensions	10 / 11 12 / 13
	mit Bremstrommel <b>N-BTG</b> with brakedrum		14 / 15
	mit anschraubbarer Bremstrommel <b>N-BTA</b> with bolted-on brakedrum		14 / 15
	mit anschraubbarer radial ausbaubarer Brems Scheibe <b>N-BSR</b> with bolted-on radial replaceable brakedisc		16
Fragebogen zur Auslegung		Questionnaire for Selection	17
Montageanleitung		Installation Instructions	18 / 19

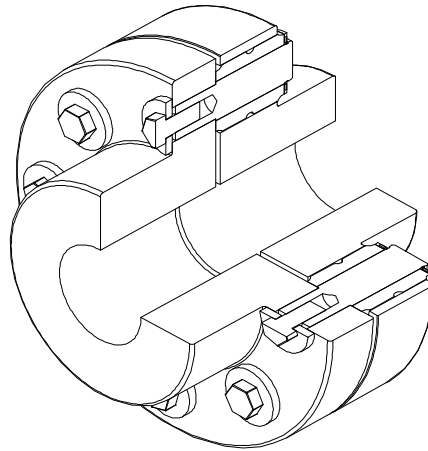

Das Recht auf Vervielfältigungen, Nachdruck und Übersetzung behalten wir uns vor. Maß- und Konstruktions-änderungen vorbehalten.

All rights of duplication, reprinting and translation are reserved. We reserve the right to modify dimensions and constructions without prior notice.

Druckschrift Nr. 02.02.10.222.08.02/02

Publication No. 02.02.10.222.08.02/02

## Allgemeines

Die VEBOFLEX-N ist eine elastische, robuste und durchschlagsichere Bolzenkupplung und stellt eine ideale Übertragung für die Leistung zwischen Getriebe und Antriebsmaschinen oder ähnlichen Anlagen dar.

Die Baureihe der VEBOFLEX-N umfasst 30 Baugrößen für Nenndrehmomente von 150 bis 552.000 Nm.

## Dynamische Eigenschaften

Die VEBOFLEX-N ist eine Kupplung mit einer progressiven Kennlinie; die dynamische Drehsteifigkeit ( $C_{Tdyn}$ ) steigt bei zunehmender Belastung der Kupplung.

Bei Nulllast ist die Drehfedersteife der VEBOFLEX-N relativ klein und es ergibt sich damit ein günstiges Verhältnis von Betriebsdrehzahl zur kritischen Drehzahl.

## General

The VEBOFLEX-N is an elastic, robust and at the same time fail safe pin and bush coupling. The VEBOFLEX-N can be employed in applications like - between gearboxes and driven-machinery or other similar configurations.

The 30 standard coupling sizes cover a nominal torque - range of 150 to 552.000 Nm.

## Dynamic Properties

The VEBOFLEX-N is a coupling with progressive characteristics, i.e. the dynamic torsional stiffness ( $C_{Tdyn}$ ) increases with increasing coupling load.

Under no-load conditions the torsional stiffness of the VEBOFLEX-N is relatively small which results in a favourable ratio between operating speed and critical speed.

## Bauformen

## Types

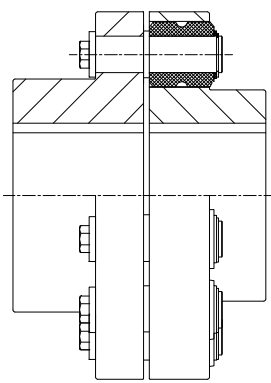
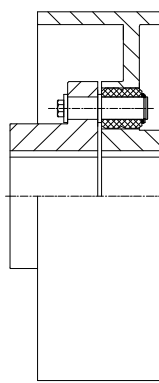
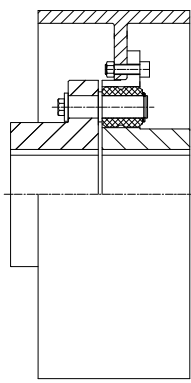
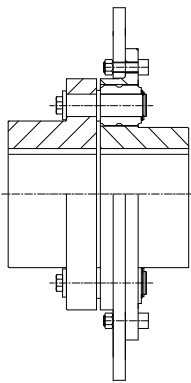
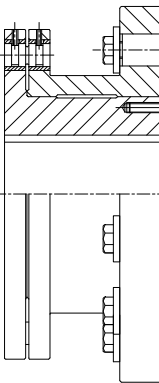
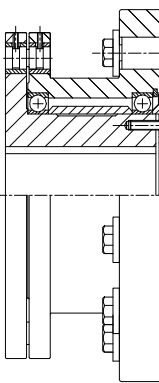
		
<p>Standard <b>N</b> Standard</p>	<p>mit Bremstrommel <b>N - BTG (DIN 15431)</b> with brakedrum</p>	<p>mit anschraubarer Bremstrommel <b>N - BTA (DIN 15431)</b> with bolted-on brakedrum</p>
		
<p>mit anschraubarer radial ausbaubarer Bremsscheibe <b>N - BSR (DIN 15432)</b> with bolted-on radial replaceable brake disc</p>	<p>mit Brechbolzen <b>N - BB *</b> with safety pins</p>	<p>mit Brechbolzen und Lagerung <b>N - BBW *</b> with safety pins and bearings</p>

\* auf Anfrage lieferbar / available on request

### Werkstoff für Metallteile

Die Teile der VEBOFLEX-N werden aus EN-GJL-250 hergestellt.

### Werkstoff für elastische Elemente

Die elastischen Elemente werden aus NBR (Acryl-Butadien-Kautschuk) angefertigt.

NBR ist ölbeständig und abriebfest, mit einem zulässigen Temperaturbereich von -20 bis +80 °C. und wird in der Shorehärte 80 °Shore A geliefert.

### Ermittlung der Kupplungsgröße

Bei der Auswahl der VEBOFLEX-N Kupplung hat man folgende zwei Alternativen :

1. Bestimmung der Kupplungsgröße unter Zugrundelegung des Antriebsmomentes. Die Ermittlung der Kupplungsgröße erfolgt entsprechend der "DIN-740 - Blatt 2".
2. Die Auslegung der Kupplung kann auch durch uns erfolgen. Die für die Auslegung benötigten technischen Daten tragen Sie bitte in **Seite 17** ein und senden uns diese zu.

### Auswuchten

Die Kupplungsteile der Bauform N ≤ Größe 260 werden in einer Ebene bei  $V \leq 36$  m/s und  $n_{\max} = 1.500$  min<sup>-1</sup>, nach VDI-2060 (ISO-1940), gewuchtet; ab Größe 260 auf Anfrage und nur mit Fertigbohrung.

Für alle Größen: Wuchten in zwei Ebenen wird empfohlen wenn es für die Laufruhe der Maschinenanlage erforderlich ist. Wuchten der Naben in zwei Ebenen ist nur möglich an Kupplungen mit Fertigbohrungen und, falls gewünscht, Nut und Stellschraube.

### Paßfedern und Bohrungen

Das Bohrungstoleranzfeld laut ISO H7 für rundstirnige Paßfeder und Nut nach DIN 6885/1.

### Massenträgheitsmoment und Masse

Die Massenträgheitsmomente (J - kg.m<sup>2</sup>) und Gewichte (M - kg) gelten für mittlere Bohrungen.

### Oberflächenbehandlung

Die Kupplungsteile der Bauform N ≤ Größe 3000 werden in Normalausführung mangan-phosphatiert. Die Vorteile einer Manganphosphat-Schicht sind die gute Korrosionsbeständigkeit und die ausgezeichnete Festigkeit gegen Abnutzung.

Diese Art der Oberflächenbehandlung ist umweltfreundlich; die behandelten Oberflächen können ohne weitere Behandlungen auch lackiert werden.

Kupplungsteile der Bauform N > 3000 werden eingeölt.

### Material for Metal Parts

The metal parts of the VEBOFLEX-N are manufactured out of EN-GJL-250.

### Material for Elastic Elements

The elastic material used for the elastic elements is NBR (Acrylonitrile-Butadiene-Rubber).

NBR is oil- and abrasion-resistant, which can be employed within a temperature range of -20 to +80 °C and is supplied in the hardness 80 °Shore A.

### Selection of the Coupling

If one is planning to select the right VEBOFLEX-N coupling there are two possible routes to follow:

1. The coupling can be selected providing that the maximum torque of the engine is known. Whenever doing this we urge you to comply to the instructions as outlined in the **DIN-740 - "Blatt - 2"**.
2. The selection can also be carried out by us. The for the selection necessary data can be sent to us after completing the form as per **Page 17**.

### Balancing

The coupling parts type N ≤ size 260 are generally balanced in one plane at  $V \leq 36$  m/s and  $n_{\max} = 1.500$  rpm according to VDI-2060 (ISO-1940), from size 260 on request and only with finished bore.

For all sizes: when required the coupling parts can be balanced in two planes. Balancing of the hubs in two planes is only possible with finished bore and when necessary keyway and setscrew.

### Keyways and Bores

Bore tolerance range according to ISO H7 and round headed parallel key and keyway according to DIN 6885/1.

### Mass Moment of Inertia and Mass

The mass moments of inertia (J - kg.m<sup>2</sup>) and masses (M - kg) refer to couplings with medium-sized bores.

### Surface Protection

The coupling parts type N ≤ size 3000 are treated with manganese phosphate. During this process a protective coating is created with the following properties: excellent corrosion protection and abrasion resistance.

The other advantages of this process are: it is not harmful to the environment and a manganese phosphated product can be painted without any additional preparation.

Coupling parts type N > 3000 are dipped in oil.

### S<sub>k</sub> - SICHERHEITSAKTOR (Tabelle 1)

Diese Betriebsfaktoren sind empirische Werte die auf AGMA und ISO Angaben und eigener Erfahrung basieren. Sie gelten für normale Betriebsbedingungen und für als Kraftmaschine verwendete Elektromotoren.

Sie können die Sicherheitsfaktoren der Tabelle 2 (Seite 6) nutzen, falls Ihre Applikation in den unteren Tabellen nicht aufgeführt ist. Liegt die Betriebsdauer < 3 Stunden pro Tag oder ist die antreibende Maschine ein 1-Zylinder Verbrennungsmotor, wenden Sie sich bitte an Ihren Lieferanten.

### S<sub>k</sub> - SAFETY FACTOR (Table 1)

These servicefactors are empirical based on AGMA and ISO specifications and our experience. They apply for normal operating conditions and for electric motors as prime movers.

Refer to the safety factors listed in table 2 (page 6) for driven machinery not listed in the table below. When the operating hours are < 3 hours per day or when a 1-cylinder combustion engine is used, please consult your supplier.

Stunden / Hours				Stunden / Hours					
3			3-10			24			
<b>GUMMI-INDUSTRIE</b>	<b>3</b>	<b>3-10</b>	<b>24</b>	<b>RUBBER INDUSTRY</b>	<b>TEXTILINDUSTRIE</b>	<b>3</b>	<b>3-10</b>	<b>24</b>	<b>TEXTILE INDUSTRY</b>
Chargenmischer	1,75	1,75	1,75	batch mixers	Kalender	1,25	1,25	1,50	Calanders
Fließmischer	1,50	1,50	1,50	continious mixers	Karden	1,25	1,25	1,50	Cards
Mischwalzen - 2 Glättwalzen	1,50	1,50	1,50	mixing-mill - 2 smooth rolls	Färbereimaschinen	1,25	1,25	1,50	Dyeing machinery
Refiner - 2 Walzen	1,50	1,50	1,50	refiner - 2 rolls	Webstühle	1,25	1,25	1,50	Looms
Kalender	1,50	1,50	1,50	Calenders	Raumaschinen	1,25	1,25	1,50	Nappers
					Schlichtmaschinen	1,25	1,25	1,50	Slashers
					Spinnmaschinen	1,25	1,25	1,50	Spinners
<b>ZUCKERINDUSTRIE</b>	<b>3</b>	<b>3-10</b>	<b>24</b>	<b>SUGAR INDUSTRY</b>	<b>NAHRUNGSMITTEL INDUSTRIE</b>	<b>3</b>	<b>3-10</b>	<b>24</b>	<b>FOOD INDUSTRY</b>
Rübenschnitzelmaschinen	2,00	2,00	2,00	beet slicer	Getreidekocher	1,00	1,00	1,25	cereal cooker
Schnitzler	1,50	1,50	1,50	cane knives	Knetmaschinen	1,25	1,25	1,50	dough mixer
Zuckerbrecher	1,50	1,50	1,50	crushers	Mühlen	1,25	1,25	1,50	meal grinders
Zuckermühlen (Abtrieb)	1,75	1,75	1,75	mills (Drive-N)	Schnitzelmaschinen	1,35	1,35	1,50	slicers
<b>WALZWERKE</b>	<b>3</b>	<b>3-10</b>	<b>24</b>	<b>METALL ROLLING MILLS</b>	<b>WALZWERKE</b>	<b>3</b>	<b>3-10</b>	<b>24</b>	<b>METALL ROLLING MILLS</b>
Schleppzangenziehbank und Hauptantriebe	1,25	1,25	1,50	draw bench carriage and main drive	Brammen-Schubmaschinen	1,50	1,50	1,50	slab pushers
Auslaufrollgang - Gruppenantrieb	1,50	1,50	1,50	runout table - group drives	Scheren	2,00	2,00	2,00	shears
Auslaufrollgang - Einzelantrieb	2,00	2,00	2,00	runout table - single drives	Drahtziehmaschinen	1,25	1,25	1,50	wire drawing
Reversier-Blockwalzwerk	2,00	2,00	2,00	reversing	Drahtwicklungsmaschinen	1,25	1,50	1,50	wire winding
<b>PAPIER INDUSTRIE</b>	<b>3</b>	<b>3-10</b>	<b>24</b>	<b>PAPER MACHINES</b>	<b>METALLBEARBEITUNGS- MASCHINEN</b>	<b>3</b>	<b>3-10</b>	<b>24</b>	<b>METALL WORKING MACHINES</b>
Rührwerke	1,50	1,50	1,50	mixer	Wickler und Abwickelhaspeln	1,00	1,00	1,25	coilers and uncoilers
Holländer	1,50	1,50	1,50	beater	Kantenschneider	1,00	1,25	1,50	edge trimmers
Kalender	1,25	1,25	1,25	calanders	Richtmaschinen	1,25	1,25	1,50	flatteners
Spanmaschinen	2,00	2,00	2,00	chipper	Biegemaschinen	1,00	1,00	1,25	loopers
Gautschwalzen	1,25	1,25	1,25	couch rolls	Klemmwalzen	1,25	1,25	1,50	pinch rolls
Schneidemaschinen	2,00	2,00	2,00	cutter	Schrotthacker	1,25	1,25	1,50	scrap shoppers
Extruder	1,50	1,50	1,50	extruder	Blechscheren	2,00	2,00	2,00	shears
Leimpresen	1,25	1,25	1,25	size press	Rollenschneidemaschinen	1,00	1,25	1,50	slitters
Glättzylinder	1,25	1,25	1,25	yankee dryers					
<b>LÜFTER</b>	<b>3</b>	<b>3-10</b>	<b>24</b>	<b>FANS</b>	<b>ZEMENTINDUSTRIE</b>	<b>3</b>	<b>3-10</b>	<b>24</b>	<b>MILLS - ROTARY TYPE</b>
Zentrifugalgebläse	1,00	1,00	1,25	centrifugal	Stabrohrmühlen				ball & rod
Kühltürme	(1)	(1)	(1)	cooling towers	- geradeverzahntes Hohlrad	2,00	2,00	2,00	- spur ring gear
Druckgebläse	1,25	1,25	1,25	forced draft	- spiralverzahntes Hohlrad	1,50	1,50	1,50	- helical ring gear
Saufzuggebläse	1,50	1,50	1,50	induced draft	- kein Übertragungselement	2,00	2,00	2,00	- direct connected
Industrie- und Grubengebläse	1,50	1,50	1,50	industrial and mining	Zementofen	1,50	1,50	1,50	cement kilns
					Trockner und Kühler	1,50	1,50	1,50	dryers & coolers
<b>BESCHICHTER</b>	<b>3</b>	<b>3-10</b>	<b>24</b>	<b>FEEDERS</b>	<b>BAGGER</b>	<b>3</b>	<b>3-10</b>	<b>24</b>	<b>DREDGES</b>
Plattenbänder	1,00	1,25	1,50	apron	Seiltrommel	1,25	1,25	1,50	cable reels
Bandförderer	1,00	1,25	1,50	belt	Förderer	1,25	1,25	1,50	conveyors
Abstreichtische	1,00	1,00	1,25	disc	Schneidköpke	2,00	2,00	2,00	cutter head drive
Rüttelschuhe	1,50	1,75	2,00	reciprocating	Pumpen	2,00	2,00	2,00	pumps
Schneckenauflieger	1,00	1,25	1,50	screws	Rechen	1,75	1,75	2,00	screens drives
					Stapler	1,25	1,25	1,50	stackers
					Seilwinden	1,25	1,25	1,50	winchies
<b>KLÄRANLAGEN</b>	<b>3</b>	<b>3-10</b>	<b>24</b>	<b>SEWAGE DISPOSAL EQUIPMENT</b>	<b>PUMPEN</b>	<b>3</b>	<b>3-10</b>	<b>24</b>	<b>PUMPS</b>
Grobrechen	1,25	1,25	1,25	bar screens	Kreiselpumpen	1,00	1,00	1,25	centrifugal
Beschicker	1,25	1,25	1,25	chemical feeders	Dosierpumpen	1,25	1,25	1,50	proportioning
Entwässerungssieb	1,50	1,50	1,50	dewatering screens	Verdrängerpumpen				reciprocating
Schwimmschlammgewinnung	1,50	1,50	1,50	scm breakers	einfach wirkend, 3 oder > Zylinder	1,25	1,25	1,50	single acting, 3 or > cylinder
langsame und schnelle Mischer	1,50	1,50	1,50	slow or rapid mixers	doppelt wirkend, 2 oder > Zylinder	1,25	1,25	1,50	double acting, 2 or > cylinder
Klarschlammabescheider	1,25	1,25	1,25	sludge collectors	Drehkolbenpumpen	1,00	1,00	1,25	rotary - gear type
Eindicker	1,50	1,50	1,50	thickeners	Zahnradpumpen	1,00	1,00	1,25	rotary - lobe
Saugfilter	1,50	1,50	1,50	vacuum filters	Flügelumpen	1,00	1,00	1,25	rotary - vane
<b>HEBEWERKE</b>	<b>3</b>	<b>3-10</b>	<b>24</b>	<b>ELEVATORS</b>	<b>EXTRUDER</b>	<b>3</b>	<b>3-10</b>	<b>24</b>	<b>EXTRUDERS</b>
Senkrechtförderer	1,50	1,50	1,50	elevators	Kunststoff	1,25	1,25	1,25	plastics
Fahrtreppen	1,25	1,25	1,25	escalators	Gummi	1,50	1,50	1,50	rubber
<b>FÖRDERANLAGEN</b>	<b>3</b>	<b>3-10</b>	<b>24</b>	<b>CONVEYORS</b>	<b>KOMPRESSOREN</b>	<b>3</b>	<b>3-10</b>	<b>24</b>	<b>COMPRESSORS</b>
mit gleichförmiger Belastung mit ungleichförmiger Belastung	1,00	1,00	1,25	uniformly loaded or fed heavy load	radialer Turboverdichter	1,00	1,25	1,25	Centrifugal lobe
- ungleichmässige Beschichtung	1,00	1,25	1,50	- not uniformly fed	Nockenkompressor	1,00	1,25	1,50	reciprocating - > 1-cylinder
- Rüttler	1,50	1,75	2,00	- reciprocating or shaker	Kolbenkompressor - > 1-Zylinder	1,50	1,50	1,75	reciprocating - 1-cylinder
					Kolbenkompressor - 1-Zylinder	1,75	1,75	2,00	
<b>GEBLÄSE</b>	<b>3</b>	<b>3-10</b>	<b>24</b>	<b>BLOWERS</b>	<b>RÜHRWERKE</b>	<b>3</b>	<b>3-10</b>	<b>24</b>	<b>AGITATORS</b>
Zentrifugal	1,00	1,00	1,25	centrifugal	reine Flüssigkeiten	1,00	1,00	1,25	pure liquids
Strahlen	1,00	1,25	1,50	lobe	flüssige und feste Stoffe	1,00	1,25	1,50	liquids and solids
Schaukel	1,00	1,25	1,50	vane	Flüssigkeiten mit veränderlichen Dichte	1,00	1,25	1,50	liquids with variable density
<b>VERSCHIEDENES</b>	<b>3</b>	<b>3-10</b>	<b>24</b>	<b>SEVERAL</b>	<b>VERSCHIEDENES</b>	<b>3</b>	<b>3-10</b>	<b>24</b>	<b>SEVERAL</b>
GENERATOREN	1,00	1,00	1,25	GENERATORS	BETONMISCHER	1,25	1,25	1,50	MIXERS - CONCRETE
HAMMERMÜHLEN	1,00	1,00	1,25	HAMMERMILLS	KRANANLAGEN		(1)		CRANES

(1) - Auf Anfrage / on request

### Sicherheitsfaktor ( $S_k$ ) - Tabelle 2

### Safety Factor ( $S_k$ ) - Table 2

	Elektromotor / Verbr. Motor $\geq 4$ Zylinder  electric motor / comb. engine $\geq 4$ cylinder	Verbr. Motor 2 - 3 Zylinder  comb. engine 2 - 3 cylinder	Verbr. Motor 1 Zylinder  comb. engine 1 cylinder
leichte Antriebe (z.B. Transportanlagen) light duty (e.g. conveyer belts)	1.0	1.3	1.7
mittlere Antriebe (z.B. industrielle Waschmaschinen) medium duty (e.g. washing machines)	1.3	1.7	2.0
schwere Antriebe (z.B. Bagger) heavy duty (e.g. dredging engines)	1.7	2.0	2.3
sehr schwere Antriebe (z.B. Hammermühlen) extra heavy duty (e.g. hammer mills)	2.0	2.3	2.7

### Sicherheitsfaktor für täglichen Betriebsdauer ( $S_b$ )

### Safety Factor for Daily Operating time ( $S_b$ )

Stunden / hours	Faktor / factor
< 2	0,90
2 - 8	1,00
8 - 16	1,15
> 16	1,25

### Anlauffaktor ( $S_z$ )

### Start-up Factor ( $S_z$ )

Faktor der die zusätzliche Belastung durch die Anfahrhäufigkeit Z (/Stunde) wie folgt berücksichtigt:

Factor which considers the additional loading caused by the start-up frequency Z (/hour) as follows:

Z $\leq$ 120	120 < Z $\leq$ 240	Z > 240
1,0	1,3	Rückfrage beim Hersteller Contact Manufacturer

### Temperaturfaktor ( $S_T$ )

### Temperature Factor ( $S_T$ )

Faktor der das Absinken der Festigkeit von gummielastischen Werkstoffen bei Wärmeeinfluß berücksichtigt. Die Temperatur  $\vartheta$  bezieht sich auf die unmittelbare Umgebung der Kupplung. Bei Einwirkung von Strahlungswärme ist dies besonders zu berücksichtigen.

Factor which accounts for the reduction of the strength of the elastic materials under the effect of heat. The temperature  $\vartheta$  refers to the immediate surroundings of the coupling. This is of particular importance in the case of radiation heat.

J ( $^{\circ}$ C)	$S_T$ (PUR)
- 20 $\leq$ $\vartheta$ < + 30	1,0
+ 30 $\leq$ $\vartheta$ < + 40	1,1
+ 40 $\leq$ $\vartheta$ < + 60	1,2
+ 60 $\leq$ $\vartheta$ < + 80	1,3

### Drehzahlfaktor ( $S_n$ )

### Rotational Speed Factor ( $S_n$ )

Faktor der den zulässigen radialen und winkligen Wellenversatz bei erhöhter Drehzahl berücksichtigt.

Factor which accounts for the permissible radial and angular shaft displacement at increasing rotational speed.

Drehzahl / Speed (min $^{-1}$ )	$S_n$
500	1,0
1.000	1,0
1.500	1,0
2.000	0,8
2.500	0,6
3.000	0,4

### ERMITTLUNG DER KUPPLUNGSGRÖßE

Die Ermittlung der Kupplungsgröße erfolgt nach der DIN-740 - Blatt 2

### COUPLING SELECTION

The selection is according to the instructions as outlined in the DIN-740 - Blatt 2

Eine VEBOFLEX-N Kupplung für den Antrieb einer Pumpe - zwischen Elektromotor und Getriebe und zwischen Getriebe und Pumpe:		A VEBOFLEX-N coupling for driving a pump - to be mounted between electricmotor and gearbox and between gearbox and pump:	
Elektromotor	$P_m = 1.400 \text{ kW}$	Electricmotor	$P_m = 1.400 \text{ kW}$
Wellen - Ø	$d_m = 140 \text{ mm}$	Shaft - Ø	$d_m = 140 \text{ mm}$
Drehzahl	$n_m = 1.500 \text{ min}^{-1}$	Speed	$n_m = 1.500 \text{ min}^{-1}$
Getriebe	$P_g = 1.290 \text{ kW}$	Gearbox	$P_g = 1.290 \text{ kW}$
Wellen - Ø - Eingang	$d_{g1} = 85 \text{ mm}$	Shaft - Ø - Input	$d_{g1} = 85 \text{ mm}$
Wellen - Ø - Ausgang	$d_{g2} = 220 \text{ mm}$	Shaft - Ø - Output	$d_{g2} = 220 \text{ mm}$
Drehzahl	$n_g = 67 \text{ min}^{-1}$	Speed	$n_g = 67 \text{ min}^{-1}$
Pumpe	$P_p = 800 \text{ kW}$	Pump	$P_p = 800 \text{ kW}$
Drehzahl	$n_p = 67 \text{ min}^{-1}$	Speed	$n_p = 67 \text{ min}^{-1}$
Wellen - Ø	$d_p = 250 \text{ mm}$	Shaft - Ø	$d_p = 250 \text{ mm}$
Tägliche Betriebsdauer	10 Stunden	Daily operating time	10 hours
Anläufe je Stunde	1	Starts per hour	1
Umgebungstemperatur	25 °C	Ambient temperatur	25 °C
<b>Beispiel / Example</b> <b>zwischen Elektromotor und Getriebe / between electricmotor and gearbox</b>			
$T(\text{Nm}) = S_k \times S_b \times S_z \times S_{\vartheta} \times \frac{9.550}{n_m (\text{min}^{-1})} \times P_g (\text{kW}) \leq T_{kN} (\text{Nm})$ $=$ $T(\text{Nm}) = 1,3 \times 1,15 \times 1,0 \times 1,0 \times \frac{9.550}{1.500 (\text{min}^{-1})} \times 1.290 (\text{kW}) = 12.278 \text{ Nm} \leq T_{kN} (\text{Nm})$			
<b>Gewählte Kupplung</b>	<b>VEBOFLEX-N 1560</b>		<b>Selected coupling</b>
<b>Beispiel / Example</b> <b>zwischen Getriebe und Pumpe / between gearbox and pump</b>			
$T(\text{Nm}) = S_k \times S_b \times S_z \times S_{\vartheta} \times \frac{9.550}{n_p (\text{min}^{-1})} \times P_p (\text{kW}) \leq T_{kN} (\text{Nm})$ $=$ $T(\text{Nm}) = 1,3 \times 1,15 \times 1,0 \times 1,0 \times \frac{9.550}{67 (\text{min}^{-1})} \times 800 (\text{kW}) = 170.474 \text{ Nm} \leq T_{kN} (\text{Nm})$			
<b>Gewählte Kupplung</b>	<b>VEBOFLEX-N 17400</b>		<b>Selected coupling</b>
Bitte beachten, ob die maximale Bohrung geeignet ist für den Wellen - Ø. Wenn nicht, wählen Sie die nächst größere Kupplung.		Check that the maximum bore is suitable for the shaft - Ø. If not, select the next larger coupling size.	

### Nennleistungen (kW) - n (Drehzahl - min<sup>-1</sup>)

Übertragbare Leistung (kW) bei den angegebenen Drehzahlen (min<sup>-1</sup>) - **Achtung** - bei Verwendung dieser Tabelle soll der Sicherheitsfaktor  $S_k$  vorher berücksichtigt werden.

### Nominal power ratings (kW) - n (speed - min<sup>-1</sup>)

Transmittable power (kW) at the following range of speeds (min<sup>-1</sup>) - **Note** - before using this table the required power rating should be multiplied with the relevant service factor  $S_k$ .

		nom. Drehmoment / nom. torque (Nm)																															
		150	260	390	580	1000	1300	1700	2600	4200	5500	7100	10100	15600	22000	30000	38200	47000	65000	86000	105000	122000	152000	174000	210000	271000	322000	349000	423000	483000	552000		
		max. Drehzahl / max. speed (min <sup>-1</sup> )																															
		4450	3950	3650	3500	2900	2600	2550	1950	1850	1700	1600	1350	1200	1110	980	890	810	900	830	770	720	680	650	620	550	530	510	490	470	450		
n (min <sup>-1</sup> )		15	26	39	58	100	130	170	260	420	550	710	1010	1560	2200	3000	3820	4700	6500	8600	10500	12200	15200	17400	21000	27100	32200	34900	42300	48300	55200		
		(kW)																															
10	0.16	0.27	0.41	0.61	1.05	1.36	1.78	2.72	4.40	5.76	7.43	10.6	16.3	23.0	31.4	40.0	49.2	68.1	90.1	110	128	159	182	220	284	337	365	443	506	578			
12.5	0.20	0.34	0.51	0.76	1.31	1.70	2.23	3.40	5.50	7.20	9.29	13.2	20.4	28.8	39.3	50.0	61.5	85.1	113	137	160	199	228	275	355	421	457	554	632	723			
16	0.25	0.44	0.65	0.97	1.68	2.18	2.85	4.36	7.04	9.21	11.9	16.9	26.1	36.9	50.3	64.0	78.7	109	144	176	204	255	292	352	454	539	585	709	809	925			
20	0.31	0.54	0.82	1.21	2.09	2.72	3.56	5.45	8.80	11.5	14.9	21.2	32.7	46.1	62.8	80.0	98.4	136	180	220	255	318	364	440	568	674	731	886	1.012	1.156			
25	0.39	0.68	1.02	1.52	2.62	3.40	4.45	6.81	11.0	14.4	18.6	26.4	40.8	57.6	78.5	100.0	123	170	225	275	319	398	455	550	709	843	914	1.107	1.264	1.445			
31.5	0.49	0.86	1.29	1.91	3.30	4.29	5.61	8.58	13.9	18.1	23.4	33.3	51.5	72.6	99.0	126	155	214	284	346	402	501	574	693	894	1.062	1.151	1.395	1.593	1.821			
40	0.63	1.09	1.63	2.43	4.19	5.45	7.12	10.9	17.6	23.0	29.7	42.3	65.3	92.1	126	160	197	272	360	440	511	637	729	880	1.135	1.349	1.462	1.772	2.023	2.312			
50	0.79	1.36	2.04	3.04	5.24	6.81	8.90	13.6	22.0	28.8	37.2	52.9	81.7	115	157	200	246	340	450	550	639	796	911	1.099	1.419	1.686	1.827	2.215	2.529	2.890			
63	0.99	1.72	2.57	3.83	6.60	8.58	11.2	17.2	27.7	36.3	46.8	66.6	103	145	198	252	310	429	567	693	805	1.003	1.148	1.385	1.788	2.124	2.302	2.790	3.186	3.641			
80	1.26	2.18	3.27	4.86	8.38	10.9	14.2	21.8	35.2	46.1	59.5	84.6	131	184	251	320	394	545	720	880	1.022	1.273	1.458	1.759	2.270	2.697	2.924	3.543	4.046	4.624			
100	1.57	2.72	4.08	6.07	10.5	13.6	17.8	27.2	44.0	57.6	74.3	106	163	230	314	400	492	681	901	1.099	1.277	1.592	1.822	2.199	2.838	3.372	3.654	4.429	5.058	5.780			
125	1.96	3.40	5.10	7.59	13.1	17.0	22.3	34.0	55.0	72.0	92.9	132	204	288	393	500	615	851	1.126	1.374	1.597	1.990	2.277	2.749	3.547	4.215	4.568	5.537	6.322	7.225			
160	2.51	4.36	6.53	9.72	16.8	21.8	28.5	43.6	70.4	92.1	119	169	261	369	503	640	787	1.089	1.441	1.759	2.044	2.547	2.915	3.518	4.540	5.395	5.847	7.087	8.092	9.248			
200	3.14	5.45	8.17	12.1	20.9	27.2	35.6	54.5	88.0	115	149	212	327	461	628	800	984	1.361	1.801	2.199	2.555	3.183	3.644	4.398	5.675	6.743	7.309	8.859	10.115	11.560			
224	3.52	6.10	9.15	13.6	23.5	30.5	39.9	61.0	98.5	129	167	237	366	516	704	896	1.102	1.525	2.017	2.463	2.862	3.565	4.081	4.926	6.356	7.553	8.186	9.922	11.329	12.947			
280	4.40	7.62	11.4	17.0	29.3	38.1	49.8	76.2	123	161	208	296	457	645	880	1.120	1.378	1.906	2.521	3.079	3.577	4.457	5.102	6.157	7.946	9.441	10.232	12.402	14.161	16.184			
315	4.95	8.58	12.9	19.1	33.0	42.9	56.1	85.8	139	181	234	333	515	726	990	1.260	1.550	2.144	2.837	3.463	4.024	5.014	5.739	6.927	8.939	10.621	11.512	13.952	15.931	18.207			
400	6.28	10.9	16.3	24.3	41.9	54.5	71.2	109	176	230	297	423	653	921	1.257	1.600	1.969	2.723	3.602	4.398	5.110	6.366	7.288	8.796	11.351	13.487	14.618	17.717	20.230	23.120			
500	7.85	13.6	20.4	30.4	52.4	68.1	89.0	136	220	288	372	529	817	1.152	1.571	2.000	2.461	3.403	4.503	5.497	6.387	7.958	9.110	10.995	14.188	16.859	18.272						
630	9.90	17.2	25.7	38.3	66.0	85.8	112	172	277	363	468	666	1.029	1.451	1.979	2.520	3.101	4.288	5.673	6.927	8.048	10.027	11.479										
730	11.5	19.9	29.8	44.3	76.4	99.4	130	199	321	420	543	772	1.192	1.682	2.293	2.920	3.593	4.969	6.574	8.026													
750	11.8	20.4	30.6	45.5	78.5	102	134	204	330	432	558	793	1.225	1.728	2.356	3.000	3.691	5.105	6.754														
800	12.6	21.8	32.7	48.6	83.8	109	142	218	352	461	595	846	1.307	1.843	2.513	3.200	3.937	5.445															
950	14.9	25.9	38.8	57.7	99.5	129	169	259	418	547	706	1.005	1.552	2.188	2.984																		
980	15.4	26.7	40.0	59.5	103	133	174	267	431	564	729	1.036	1.601	2.258	3.079																		
1.000	15.7	27.2	40.8	60.7	105	136	178	272	440	576	743	1.058	1.634	2.304																			
1.120	17.6	30.5	45.7	68.0	117	152	199	305	493	645	833	1.185	1.830																				
1.250	19.6	34.0	51.0	75.9	131	170	223	340	550	720	929	1.322																					
1.430	22.5	38.9	58.4	86.8	150	195	255	389	629	824	1.063																						
1.600	25.1	43.6	65.3	97.2	168	218	285	436	704	921	1.190																						
1.750	27.5	47.6	71.5	106	183	238	312	476	770																								
2.000	31.4	54.5	81.7	121	209	272	356																										
2.500	39.3	68.1	102	152	262	340	445																										
2.940	46.2	80.0	120	179																													
3.150	49.5	85.8	129	191																													
3.500	55.0	95.3	143	213																													
4.000	62.8																																
5.000																																	

**TECHNISCHE ECKDATEN**

**zulässige Wellenversätze**

Die aufgeführten Verlagerungswerte gelten bei Nenndrehmomente, stoßfreiem Betrieb, Drehzahl = 1.500 min<sup>-1</sup> und Umgebungstemperatur - 20°C bis + 80°C.

Zulässiger Versatz ist  $\Delta K_{r,zul} \cdot S_n$  bzw.  $\Delta K_{w,zul} \cdot S_n$  ( $S_n$  - Seite 6).  $\Delta K_r$  und  $\Delta K_w$  können gleichzeitig auftreten. Die %-Summe der beiden vorhandenen Versätze  $\Delta K_{a,vorh}$  und  $\Delta K_{w,vorh}$  ist maximal 100%.

**TECHNICAL DETAILS**

**permissible shaft misalignment**

The listed displacement values apply at nominal torque, under shock-free operating conditions, nominal speed = 1.500 min<sup>-1</sup> and ambient temperatures - 20°C to + 80°C.

Permissible displacement is  $\Delta K_{r,zul} \cdot S_n$  or  $\Delta K_{w,zul} \cdot S_n$  ( $S_n$  - Page 6).  $\Delta K_r$  and  $\Delta K_w$  could occur simultaneously. The %-sum of the two measured displacements  $\Delta K_{a,vorh}$  and  $\Delta K_{w,vorh}$  should not exceed 100%.

$\frac{\Delta K_{r,vorh}}{\Delta K_{r,zul}} \times 100\% + \frac{\Delta K_{w,vorh}}{\Delta K_{w,zul}} \times 100\% \leq 100\%$	$\Delta K_{r,zul} / \Delta K_{w,zul} =$ zulässige Versätze / permissible displacements $\Delta K_{r,vorh} / \Delta K_{w,vorh} =$ vorhandene Versätze / measured displacements
--	--

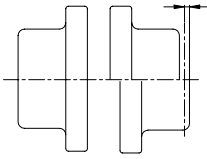
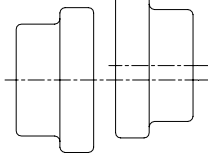
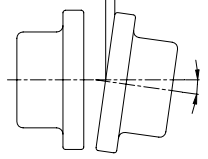
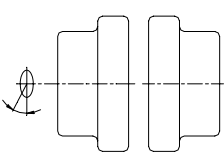
axialer Wellenversatz $\Delta K_a$ (mm) axial shaft displacement	radialer Wellenversatz $\Delta K_r$ (mm) radial shaft displacement	winkliger Wellenversatz $\Delta K_w$ (mm / °) angular shaft displacement	Verdrehwinkel $\alpha$ (°) torsional angle
			

Größe Size	Nennmoment $T_{KN}$ nominal torque	max Drehmoment $T_{kmax}$ max torque	max Drehzahl $n_{max}$ max speed	Verdrehwinkel Nennmoment $\alpha$ torsional angle nominal torque	Verdrehwinkel max. Moment $\alpha$ torsional angle max. torque	axialer Wellenversatz $\Delta K_a$ axial misalignment	radialer Wellenversatz $\Delta K_r$ radial misalignment	winkliger Wellenversatz $\Delta K_w$ angular misalignment
	(Nm)		(min <sup>-1</sup> )	(°)		(mm)		(°)
15	150	300	4.450	1,1	1,4	± 1,0	0,5	± 0,35 0,33
26	260	520	3.950	1,1	1,4	± 1,0	0,5	± 0,35 0,29
39	390	780	3.650	1,1	1,4	± 1,0	0,5	± 0,35 0,27
58	580	1.160	3.500	1,1	1,4	± 1,0	0,5	± 0,35 0,25
100	1.000	2.000	2.900	1,1	1,4	± 1,0	0,5	± 0,35 0,21
130	1.300	2.600	2.600	1,1	1,4	± 1,0	0,5	± 0,35 0,19
170	1.700	3.400	2.550	1,1	1,4	± 1,0	0,5	± 0,35 0,19
260	2.600	5.200	1.950	1,1	1,4	± 1,5	1,0	± 0,50 0,20
420	4.200	8.400	1.850	1,1	1,4	± 1,5	1,0	± 0,50 0,19
550	5.500	11.000	1.700	1,1	1,4	± 1,5	1,0	± 0,50 0,18
710	7.100	14.200	1.600	1,1	1,4	± 2,0	1,0	± 0,50 0,17
1010	10.100	20.200	1.350	1,1	1,4	± 2,0	1,0	± 0,65 0,18
1560	15.600	31.200	1.200	1,1	1,4	± 2,0	1,0	± 0,65 0,17
2205	22.000	44.000	1.110	1,1	1,4	± 2,5	1,0	± 0,65 0,15
3000	30.000	60.000	1.090	1,1	1,4	± 2,5	1,0	± 0,85 0,17
3820	38.200	76.400	990	1,1	1,4	± 2,5	1,0	± 0,85 0,16
4700	47.000	94.000	890	1,1	1,4	± 3,0	1,0	± 0,85 0,14
6500	65.000	130.000	890	1,1	1,4	± 3,0	1,5	± 1,00 0,17
8600	86.000	172.000	830	1,1	1,4	± 3,0	1,5	± 1,00 0,16
10500	105.000	210.000	770	1,1	1,4	± 3,0	1,5	± 1,00 0,15
12200	122.000	244.000	720	1,1	1,4	± 3,0	1,5	± 1,00 0,14
15200	152.000	304.000	680	1,1	1,4	± 3,0	2,0	± 1,00 0,13
17400	174.000	348.000	650	1,1	1,4	± 3,0	2,0	± 1,00 0,12
21000	210.000	420.000	620	1,1	1,4	± 3,0	2,0	± 1,00 0,12
27100	271.000	542.000	550	1,1	1,4	± 3,0	2,0	± 1,00 0,10
32300	322.000	646.000	530	1,1	1,4	± 3,0	2,0	± 1,00 0,10
34900	349.000	698.000	510	1,1	1,4	± 3,0	2,0	± 1,00 0,09
42300	423.000	846.000	490	1,1	1,4	± 3,0	2,0	± 1,00 0,09
48300	483.000	966.000	470	1,1	1,4	± 3,0	2,0	± 1,00 0,08
55200	552.000	1.104.000	450	1,1	1,4	± 3,0	2,0	± 1,00 0,08

Bauart N

Type N

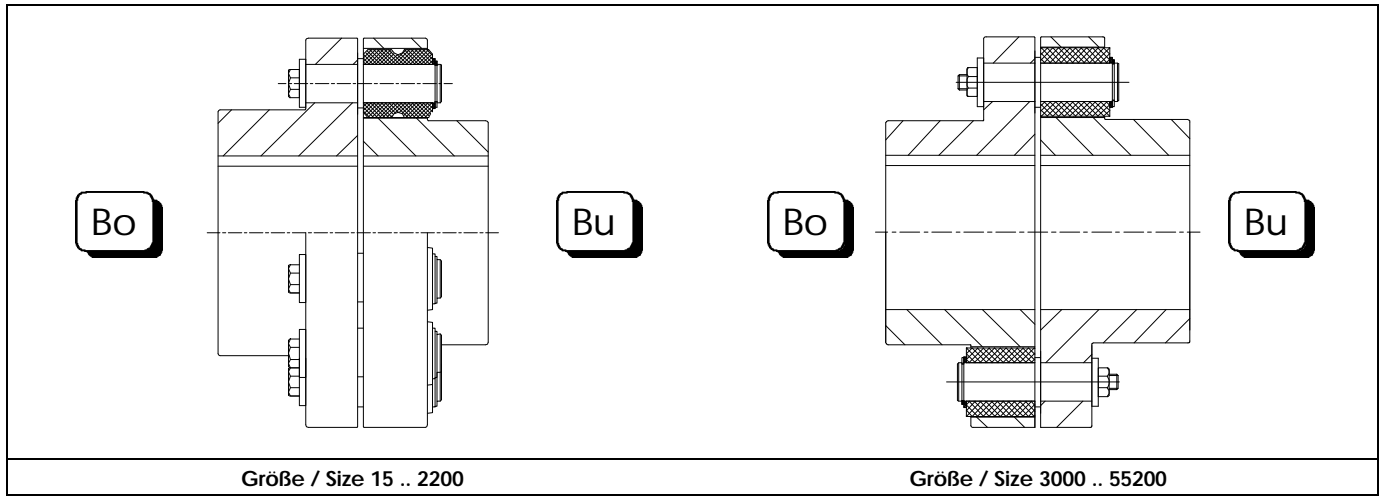

Größe Size	Masse		Massenträgheit		Größe Bolzen/Gummi size pin /rubber	Anzahl Bolzen quantity pins
	M <sub>bo</sub>	M <sub>bu</sub>	J <sub>bo</sub>	J <sub>bu</sub>		
	mass		mass moment of inertia			
	(kg)		(kg.m <sup>2</sup> )			
15	2,1	1,9	0,0025	0,0032	1	3
26	3,0	2,7	0,0041	0,0052	1	5
39	4,1	3,7	0,0055	0,0071	1	6
58	4,8	4,2	0,0069	0,0088	1	9
100	9,4	8,5	0,0142	0,0184	1	13
130	11,9	10,8	0,0282	0,0329	2	11
170	13,4	12,0	0,0311	0,6361	2	14
260	27,5	24,8	0,1442	0,1857	3	6
420	32,3	28,0	0,1677	0,2128	3	10
550	42,4	37,2	0,2452	0,3128	3	12
710	47,4	41,0	0,2941	0,3758	3	15
1010	87,3	77,0	0,8730	1,1674	4	9
1560	114,0	99,0	1,2090	1,6134	4	13
2205	155,0	135,0	1,7624	2,3637	4	17
3000	192,0	192,0	4,7423	4,7423	5	14
A	131,0	131,0	4,6304	4,6304	5	14
B	108,0	108,0	4,6064	4,6064	5	14
3820	197,0	197,0	7,1198	7,1198	5	16
A	167,0	167,0	6,9596	6,9596	5	16
B	135,0	135,0	6,6682	6,6682	5	16
4700	260,0	260,0	9,9979	9,9979	5	18
A	228,0	228,0	9,6126	9,6126	5	18
B	182,0	182,0	9,1005	9,1005	5	18
6500	332,0	332,0	15,6207	15,6207	6	10
A	276,0	276,0	15,1795	15,1795	6	10
B	233,0	233,0	14,8023	14,8023	6	10
8600	397,0	397,0	20,6983	20,6983	6	12
A	331,0	331,0	20,0060	20,0060	6	12
B	274,0	274,0	19,6328	19,6328	6	12
10500	494,0	494,0	27,6129	27,6129	6	14
A	443,0	443,0	26,3333	26,1333	6	14
B	381,0	381,0	26,0032	26,0032	6	14
C	330,0	330,0	25,7388	25,7388	6	14
12200	554,0	554,0	36,1301	36,1301	6	16
A	492,0	492,0	35,4471	35,4471	6	16
B	428,0	428,0	35,0075	35,0075	6	16
C	374,0	374,0	34,7002	34,7002	6	16

Ausführung A-B-C sind auf Anfrage lieferbar

Execution A-B-C are available on request

Bauart N

Type N

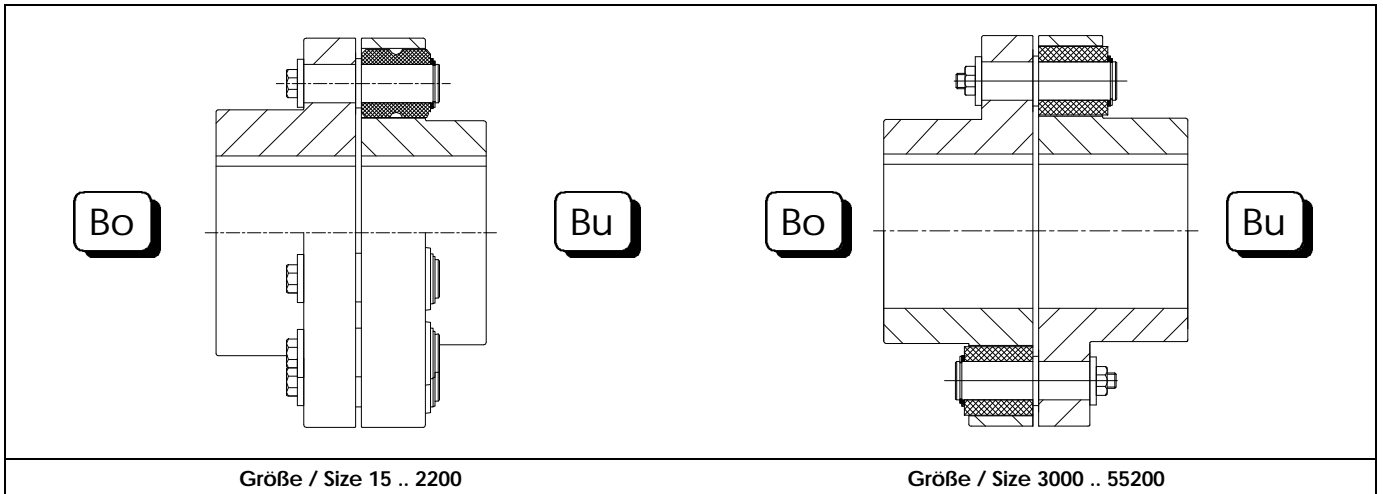

Größe Size	Masse		Massenträgheit		Größe Bolzen/Gummi	Anzahl Bolzen
	M <sub>Bo</sub>	M <sub>Bu</sub>	J <sub>Bo</sub>	J <sub>Bu</sub>		
	mass		mass moment of inertia		size pin /rubber	quantity pins
	(kg)		(kg.m <sup>2</sup> )			
<b>15200</b>	641,0	641,0	50,0555	50,0555	7	10
A	561,0	561,0	48,2634	48,2634	7	10
B	447,0	447,0	47,1652	47,1652	7	10
C	392,0	392,0	46,4578	46,4578	7	10
<b>17400</b>	698,0	698,0	58,2694	58,2694	7	12
A	601,0	601,0	56,9113	56,9113	7	12
B	432,0	432,0	55,3331	55,3331	7	12
C	412,0	412,0	54,7662	54,7662	7	12
<b>21000</b>	841,0	841,0	71,6177	71,6177	7	12
A	730,0	730,0	69,3871	69,3871	7	12
B	640,0	640,0	68,2800	68,2800	7	12
C	555,0	555,0	67,6551	67,6551	7	12
<b>27100</b>	1.021,0	1.021,0	111,0308	111,0308	7	14
A	910,0	910,0	108,7113	108,7113	7	14
B	807,0	807,0	106,2991	106,2991	7	14
C	712,0	712,0	103,8978	103,8978	7	14
<b>32300</b>	1.074,0	1.074,0	149,2661	149,2661	7	16
A	921,0	921,0	143,7840	143,7840	7	16
B	877,0	877,0	140,0778	140,0778	7	16
C	804,0	804,0	136,1354	136,1354	7	16
<b>34900</b>	1.149,0	1.149,0	170,3095	170,3095	7	16
A	1.007,0	1.007,0	163,9110	163,9110	7	16
B	876,0	876,0	158,7148	158,7148	7	16
C	759,0	759,0	152,2400	152,2400	7	16
<b>42300</b>	1.380,0	1.380,0	232,7185	232,7185	7	18
A	966,0	966,0	226,1477	226,1477	7	18
B	906,0	906,0	223,0033	223,0033	7	18
C	853,0	853,0	219,2514	219,2514	7	18
<b>48300</b>	1.613,0	1.613,0	298,0246	298,0246	7	18
A	1.438,0	1.438,0	292,4123	292,4123	7	18
B	1.270,0	1.270,0	286,3971	286,3971	7	18
C	1.118,0	1.118,0	282,3273	282,3273	7	18
<b>55200</b>	1.681,0	1.681,0	376,2763	376,2763	7	20
A	1.485,0	1.485,0	368,5047	368,5047	7	20
B	1.329,0	1.329,0	361,4518	361,4518	7	20
C	1.189,0	1.189,0	357,3766	357,3766	7	20

Ausführung A-B-C sind auf Anfrage lieferbar

Execution A-B-C are available on request

Bauart N

Type N

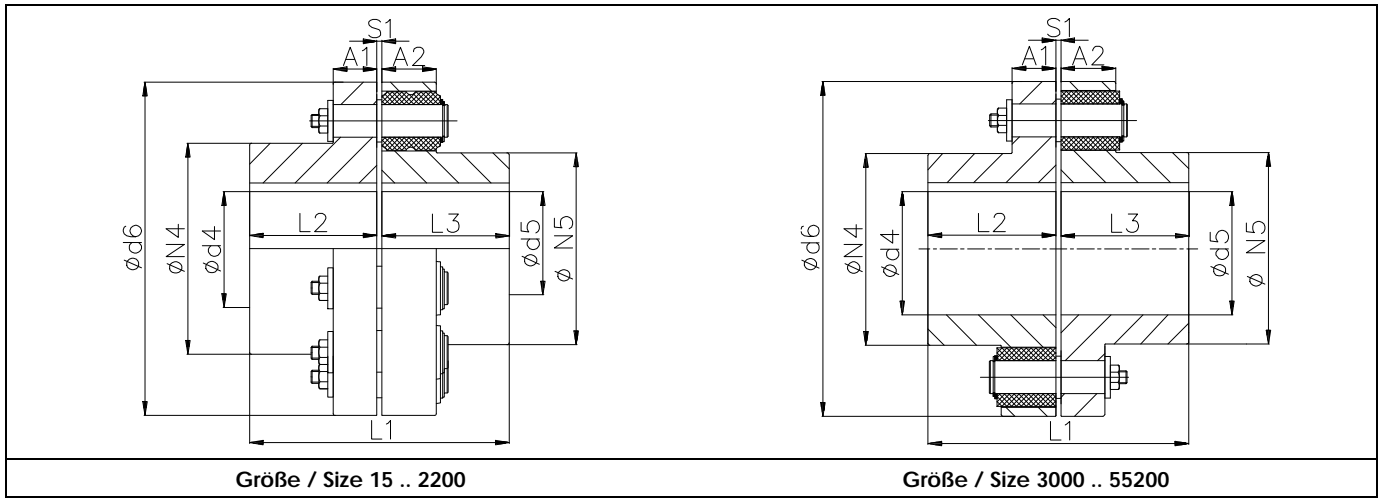

Größe / Size 15 .. 2200

Größe / Size 3000 .. 55200

Größe	Vor-bohrung	max Bohrung	Vor-bohrung	max Bohrung	$d_6$	$L_1$	$L_2$	$L_3$	$L_1$	$L_2$	$L_3$	$N_4$	$N_5$	$A_1$	$A_2$	$S_1$
	$d_4$		$d_5$													
Size	Vor-bohrung	max Bohrung	Vor-bohrung	max Bohrung	(mm)											
15	0	38	0	38	123	92	45		106	52	61	61	15	20	2	
26	0	48	0	48	139	112	55		130	64	77	77	15	20	2	
39	0	55	0	55	150	132	65		142	70	88	88	15	20	2	
58	0	60	0	60	158	142	70		152	75	96	96	15	20	2	
100	0	80	0	80	190	182	90		200	99	128	128	15	20	2	
130	0	85	0	85	210	193	95		211	104	136	136	20	24	3	
170	0	90	0	90	215	203	100		221	109	144	144	20	24	3	
260	0	110	0	110	285	225	110		275	135	176	176	30	40	5	
420	0	115	0	115	295	265	130		315	155	184	184	30	40	5	
550	0	130	0	130	325	285	140		345	170	208	208	30	40	5	
710	0	140	0	140	340	285	140		345	170	224	224	30	40	5	
1010	0	165	0	165	415	346	170		406	200	264	264	40	56	6	
1560	90	180	90	180	450	406	200		466	230	288	288	40	56	6	
2205	100	200	100	200	495	466	230		526	260	320	320	40	56	6	
3000	105	210	105	210	560	428	210		488	240	336	336	68	68	8	
A	0	160	0	160	560	428	210		488	240	256	256	68	68	8	
B	0	110	0	110	560	428	210		488	240	176	176	68	68	8	
3820	110	220	110	220	620	498	245		558	275	352	352	68	68	8	
A	80	170	80	170	620	498	245		558	275	272	272	68	68	8	
B	0	120	0	120	620	498	245		558	275	192	192	68	68	8	
4700	120	240	120	240	675	588	290		648	320	384	384	68	68	8	
A	90	190	90	190	675	588	290		648	320	304	304	68	68	8	
B	0	140	0	140	675	588	290		648	320	224	224	68	68	8	
6500	130	260	130	260	685	589	290		649	320	416	416	100	100	9	
A	100	210	100	210	685	589	290		649	320	336	336	100	100	9	
B	0	160	0	160	685	589	290		649	320	256	256	100	100	9	
8600	145	290	145	290	735	609	300		679	335	464	464	100	100	9	
A	120	235	120	235	735	609	300		679	335	376	376	100	100	9	
B	90	180	90	180	735	609	300		679	335	288	288	100	100	9	
10500	155	305	155	305	790	709	350		779	385	488	488	100	100	9	
A	130	265	130	265	790	709	350		779	385	424	424	100	100	9	
B	110	225	110	225	790	709	350		779	385	360	360	100	100	9	
C	90	185	90	185	790	709	350		779	385	296	296	100	100	9	
12200	160	315	160	315	845	709	350		779	385	504	504	100	100	9	
A	130	275	130	275	845	709	350		779	385	440	440	100	100	9	
B	110	235	110	235	845	709	350		779	385	376	376	100	100	9	
C	90	195	90	195	845	709	350		779	385	312	312	100	100	9	

Geeignet für Axialdruckscheiben ähnlich zu DIN 28135

(1)

suitable for axial pressure plates similar to DIN 28135

AUF ANFRAGE LIEFERBAR

AVAILABLE ON REQUEST

Ausführung A-B-C sind auf Anfrage lieferbar

Execution A-B-C are available on request

Bauart N

Type N

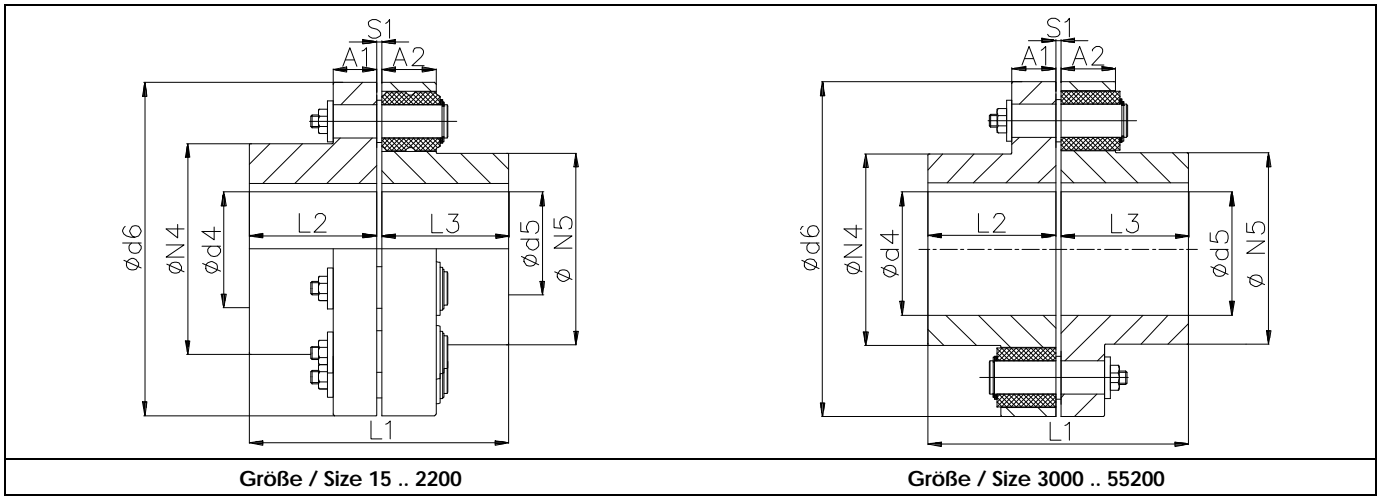

Größe Size	Vor-bohrung d <sub>4</sub>		max Bohrung d <sub>5</sub>		d <sub>6</sub>	L <sub>1</sub>	L <sub>2</sub>	L <sub>3</sub>	L <sub>1</sub>	L <sub>2</sub>	L <sub>3</sub>	N <sub>4</sub>	N <sub>5</sub>	A <sub>1</sub>	A <sub>2</sub>	S <sub>1</sub>
	Vor-bohrung	max Bohrung	Vor-bohrung	max Bohrung												
(mm)																
<b>15200</b>	165	325	165	325	905	710	350		790	390	520	520	105	105	10	
A	140	285	140	285	905	710	350		790	390	456	456	105	105	10	
B	120	245	120	245	905	710	350		790	390	392	392	105	105	10	
C	100	205	100	205	905	710	350		790	390	328	328	105	105	10	
<b>17400</b>	175	345	175	345	940	710	350		790	390	552	552	105	105	10	
A	150	305	150	305	940	710	350		790	390	488	488	105	105	10	
B	130	265	130	265	940	710	350		790	390	424	424	105	105	10	
C	110	225	110	225	940	710	350		790	390	360	360	105	105	10	
<b>21000</b>	180	360	180	360	990	830	410		910	450	576	576	105	105	10	
A	160	320	160	320	990	830	410		910	450	512	512	105	105	10	
B	140	280	140	280	990	830	410		910	450	448	448	105	105	10	
C	120	240	120	240	990	830	410		910	450	384	384	105	105	10	
<b>27100</b>	195	385	195	385	1.105	830	410		930	460	616	616	105	105	10	
A	170	345	170	345	1.105	830	410		930	460	552	552	105	105	10	
B	150	305	150	305	1.105	830	410		930	460	488	488	105	105	10	
C	130	265	130	265	1.105	830	410		930	460	424	424	105	105	10	
<b>32300</b>	205	410	205	410	1.190	950	470		1.040	515	656	656	105	105	10	
A	180	370	180	370	1.190	950	470		1.040	515	592	592	105	105	10	
B	160	330	160	330	1.190	950	470		1.040	515	528	528	105	105	10	
C	140	290	140	290	1.190	950	470		1.040	515	464	464	105	105	10	
<b>34900</b>	215	425	215	420	1.230	930	460		1.030	510	680	680	105	105	10	
A	190	385	190	385	1.230	930	460		1.030	510	616	616	105	105	10	
B	170	345	170	345	1.230	930	460		1.030	510	552	552	105	105	10	
C	150	305	150	305	1.230	930	460		1.030	510	488	488	105	105	10	
<b>42300</b>	225	450	225	450	1.330	950	470		1.040	515	720	720	105	105	10	
A	200	410	200	410	1.330	950	470		1.040	515	656	656	105	105	10	
B	180	370	180	370	1.330	950	470		1.040	515	592	592	105	105	10	
C	160	330	160	330	1.330	950	470		1.040	515	528	528	105	105	10	
<b>48300</b>	235	470	235	470	1.415	1.030	510		1.130	560	752	752	105	105	10	
A	210	430	210	430	1.415	1.030	510		1.130	560	688	688	105	105	10	
B	190	390	190	390	1.415	1.030	510		1.130	560	624	624	105	105	10	
C	170	350	170	350	1.415	1.030	510		1.130	560	560	560	105	105	10	
<b>55200</b>	240	480	240	480	1.500	950	470		1.050	520	768	768	105	105	10	
A	220	440	220	440	1.500	950	470		1.050	520	704	704	105	105	10	
B	200	400	200	400	1.500	950	470		1.050	520	640	640	105	105	10	
C	180	360	180	360	1.500	950	470		1.050	520	576	576	105	105	10	

Geeignet für Axialdruckscheiben ähnlich zu DIN 28135 (1) suitable for axial pressure plates similar to DIN 28135  
 AUF ANFRAGE LIEFERBAR AVAILABLE ON REQUEST  
 Ausführung A-B-C sind auf Anfrage lieferbar Execution A-B-C are available on request

**Bauart N-BTG/BTA**

**Type N-BTG/BTA**

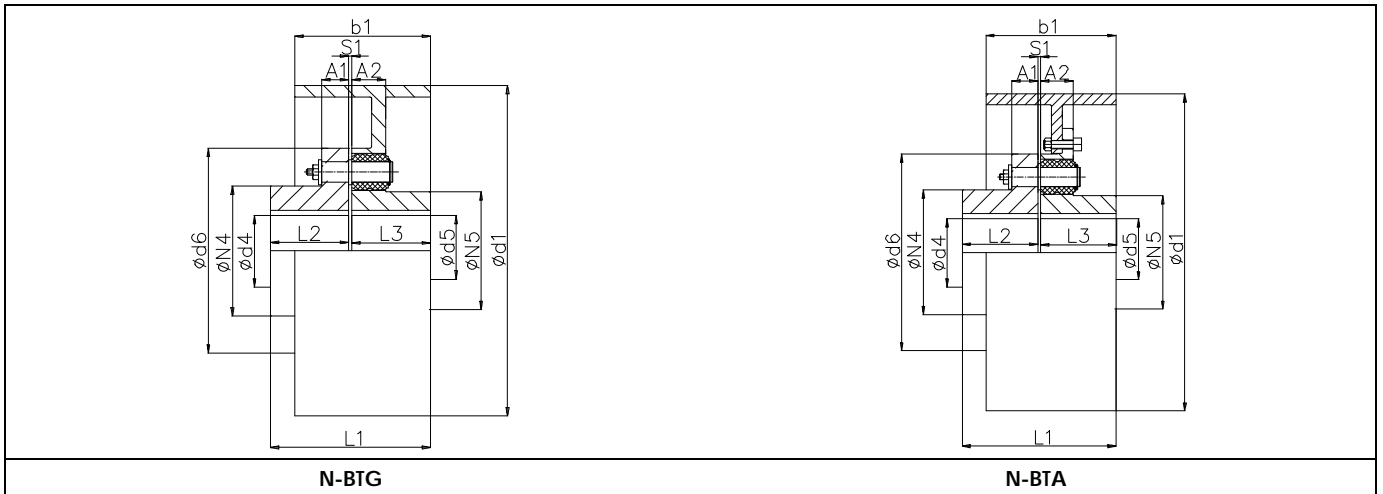

Größe Size	Bremsstrommel		Vor- bohrung	max Bohrung	Vor- bohrung	max Bohrung									
	d <sub>1</sub> x b <sub>1</sub> BTG	d <sub>1</sub> x b <sub>1</sub> BTA	d <sub>4</sub>	d <sub>4</sub>	d <sub>5</sub>	d <sub>5</sub>	d <sub>6</sub>	L <sub>1</sub>	L <sub>2</sub>	L <sub>3</sub>	N <sub>4</sub>	N <sub>5</sub>	A <sub>1</sub>	A <sub>2</sub>	S <sub>1</sub>
	brakedrum		pilot bore	max bore	pilot bore	max bore									
	(mm x mm)		(mm)												
15	200 x 075 250 x 095	200 x 075 250 x 095	0	38	0	38	123	92	45	45	61	61	15	20	2
26	200 x 175 250 x 095	200 x 175 250 x 095	0	48	0	48	139	112	55	55	77	77	15	20	2
39	200 x 075 250 x 095 315 x 118	- 250 x 095 315 x 118	0	55	0	55	150	132	65	65	88	88	15	20	2
58	200 x 075 250 x 095 315 x 118	- 250 x 095 315 x 118	0	60	0	60	158	142	70	70	96	96	15	20	2
100	250 x 095 315 x 118 400 x 150	- 315 x 118 400 x 150	0	80	0	80	190	182	90	90	128	128	15	20	2
130	250 x 095 315 x 118 400 x 150	315 x 118 400 x 150	0	85	0	85	210	193	95	95	136	136	20	24	3
170	250 x 095 315 x 118 400 x 150	- 315 x 118 400 x 150	0	90	0	90	215	203	100	100	144	144	20	24	3
260	315 x 118 400 x 150 500 x 190	- 400 x 150 500 x 190	0	110	0	110	285	225	110	110	176	176	30	40	5
420	400 x 150 500 x 190	400 x 150 500 x 190	0	115	0	115	295	265	130	130	184	184	30	40	5
550	400 x 150 500 x 190 630 x 236	- 500 x 190 630 x 236	0	130	0	130	325	285	140	140	208	208	30	40	5
710	400 x 150 500 x 190 630 x 236	- 500 x 190 630 x 236	0	140	0	140	340	285	140	140	224	224	30	40	5
1010	500 x 190 630 x 236 710 x 265	- 630 x 236 710 x 265	0	165	0	165	415	346	170	170	264	264	40	56	6
1560	500 x 190 630 x 236 710 x 265	- 630 x 236 710 x 265	90	185	90	185	450	406	200	200	288	288	40	56	6

**Bauart N-BTG/BTA**

**Type N-BTG/BTA**

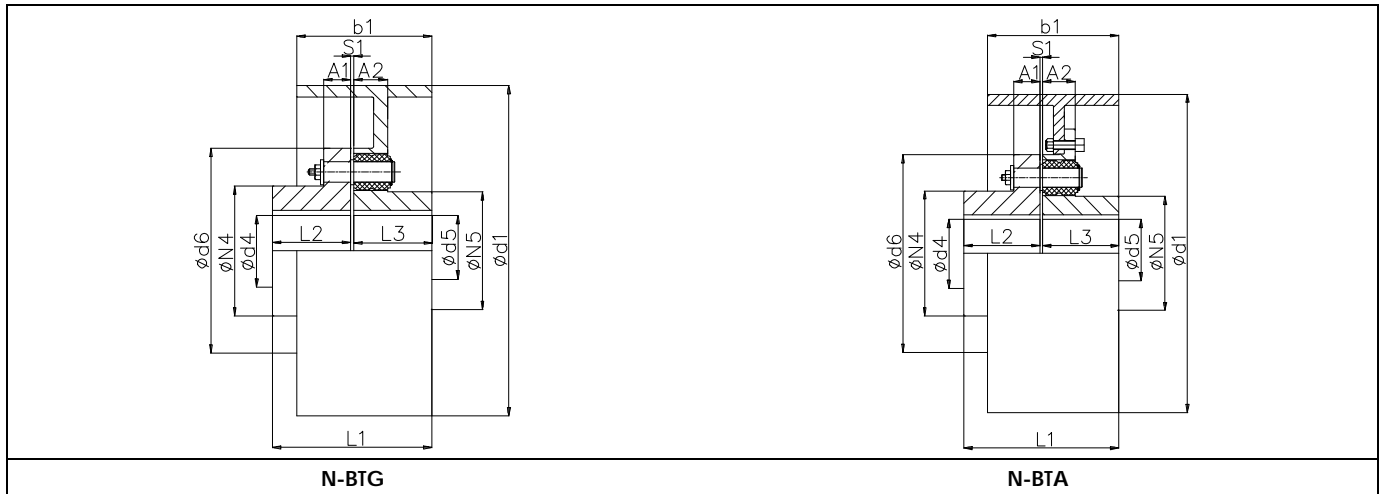

Größe Size	Brems- trommel	Nenn- moment	max Drehzahl	Masse		Massenträgheits- moment		Größe Bolzen	Anzahl Bolzen
	<b>d<sub>1</sub> x b<sub>1</sub> BTG/BTA</b>	<b>T<sub>kN</sub></b>	<b>n<sub>max</sub></b>	<b>M<sub>bo</sub></b>	<b>M<sub>bu</sub></b>	<b>J<sub>bo</sub></b>	<b>J<sub>bu</sub></b>		
	brake drum	nominal torque	max speed	mass		mass moment of inertia		size pin	quantity pins
	(mm x mm)	(Nm)	(min <sup>-1</sup> )	(kg)		(kg.m <sup>2</sup> )			
<b>15</b>	200 x 075	150	3.450	2,1	7,2	0,0025	0,0383	1	3
	250 x 095		2.750		12,8		0,1082		
<b>26</b>	200 x 175	260	3.450	3,0	7,7	0,0041	0,0404	1	5
	250 x 095		2.750		13,2		0,1103		
<b>39</b>	200 x 075	390	3.450	4,1	8,4	0,0055	0,0422	1	6
	250 x 095		2.750		13,9		0,1121		
	315 x 118		2.750		21,7		0,2780		
<b>58</b>	200 x 075	580	3.450	4,8	8,7	0,0069	0,0439	1	9
	250 x 095		2.750		14,2		0,1138		
	315 x 118		2.750		22,0		0,2797		
<b>100</b>	250 x 095	1.000	2.750	9,4	17,5	0,0142	0,1234	1	13
	315 x 118		2.200		25,7		0,2893		
	400 x 150		1.700		39,5		0,7455		
<b>130</b>	250 x 095	1.300	2.750	11,9	18,9	0,0282	0,1379	2	11
	315 x 118		2.200		27,0		0,3038		
	400 x 150		1.700		40,9		0,7600		
<b>170</b>	250 x 095	1.700	2.750	13,4	19,8	0,0311	0,1411	2	14
	315 x 118		2.200		27,9		0,3070		
	400 x 150		1.700		41,8		0,7633		
<b>260</b>	315 x 118	2.600	2.200	27,5	36,8	0,1442	0,4566	3	6
	400 x 150		1.700		50,7		0,9129		
	500 x 190		1.400		80,8		2,5663		
<b>420</b>	400 x 150	4.200	1.700	32,3	53,2	0,1677	0,9399	3	10
	500 x 190		1.400		83,3		2,5933		
	630 x 236		1.100		129,7		6,3786		
<b>550</b>	400 x 150	5.500	1.700	42,4	65,7	0,2452	1,2473	3	12
	500 x 190		1.400		90,4		2,6944		
	630 x 236		1.100		129,7		6,3786		
<b>710</b>	400 x 150	7.100	1.700	47,4	68,2	0,2941	1,3092	3	15
	500 x 190		1.400		93,0		2,7564		
	630 x 236		1.100		132,3		6,4406		
<b>1010</b>	500 x 190	10.100	1.400	87,3	123,9	0,8730	3,5479	4	9
	630 x 236		1.100		167,8		7,2322		
	710 x 265		950		200,2		11,0213		
<b>1560</b>	500 x 190	15.600	1.400	114,4	141,8	1,2090	3,9940	4	13
	630 x 236		1.100		185,8		7,6783		
	710 x 265		950		218,2		11,4674		

Bauart N-BSR - Metrisch

Type N-BSR - Metric

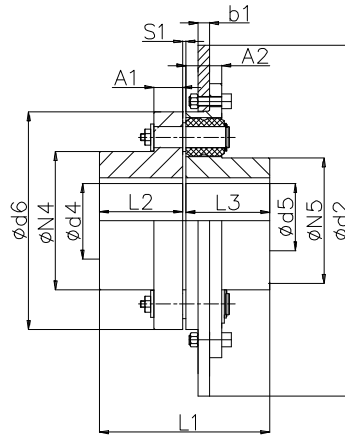

N-BSR

Größe Size	Brems-scheibe brake disc		Vor-bohrung pilot bore	max Bohrung max bore	Vor-bohrung pilot bore	max Bohrung max bore	d <sub>6</sub>	L <sub>1</sub>	L <sub>2</sub>	L <sub>3</sub>	N <sub>4</sub>	N <sub>5</sub>	A <sub>1</sub>	A <sub>2</sub>	S <sub>1</sub>
	d <sub>2</sub> x b <sub>1</sub>		d <sub>4</sub>	d <sub>4</sub>	d <sub>5</sub>	d <sub>5</sub>	(mm)								
	(mm x mm)		(mm)												
15	250 x 15	315 x 30	0	38	0	38	123	92	45	45	61	61	15	20	2
26	315 x 30	400 x 30	0	48	0	48	139	112	55	55	77	77	15	20	2
39	315 x 30	400 x 30	0	55	0	55	150	132	65	65	88	88	15	20	2
58	315 x 30	400 x 30	0	60	0	60	158	142	70	70	96	96	15	20	2
100	400 x 30	500 x 30	0	80	0	80	190	182	90	90	128	128	15	20	2
130	400 x 30	500 x 30	0	85	0	85	210	193	95	95	136	136	20	24	3
170	500 x 30	630 x 30	0	90	0	90	215	203	100	100	144	144	20	24	3
260	630 x 30	710 x 30	0	110	0	110	285	225	110	110	176	176	30	40	5
420	630 x 30	710 x 30	0	115	0	115	295	265	130	130	184	184	30	40	5
550	630 x 30	710 x 30	0	130	0	130	325	285	140	140	208	208	30	40	5
710	630 x 30	710 x 30	0	10	0	10	340	285	140	140	224	224	30	40	5
1010	800 x 30	900 x 30	0	165	0	165	415	346	170	170	264	264	40	56	6
1560	-	900 x 30	90	180	90	180	450	406	200	200	288	288	40	56	6

Größe Size	Brems-scheibe brake disc	Nenn-moment nominal torque	max Drehzahl max speed	Masse mass		Massenträgheits-moment mass moment of inertia		Größe Bolzen size pin	Anzahl Bolzen quantity pins
	d <sub>2</sub> x b <sub>1</sub>	T <sub>kN</sub>	n <sub>max</sub>	M <sub>bo</sub>	M <sub>bu</sub>	J <sub>bo</sub>	J <sub>bu</sub>		
	(mm x mm)	(Nm)	(min <sup>-1</sup> )	(kg)		(kg.m <sup>2</sup> )			
15	250 x 15 315 x 30	150	2.750 2.750	2,1	5,9 16,1	0,0025	0,0422 0,2071	1	3
26	315 x 30 400 x 30	260	2.750 1.700	3,0	16,3 26,6	0,0041	0,2061 0,5402	1	5
39	315 x 30 400 x 30	390	2.750 1.700	4,1	16,7 27,0	0,0055	0,2052 0,5393	1	6
58	315 x 30 400 x 30	580	2.750 1.700	4,8	16,8 27,1	0,0069	0,2043 0,5384	1	9
100	400 x 30 500 x 30	1.000	1.700 1.400	9,4	29,6 44,8	0,0142	0,5336 1,3161	1	13
130	400 x 30 500 x 30	1.300	1.700 1.400	11,9	30,5 45,7	0,0282	0,5345 1,3170	2	11
170	500 x 30 630 x 30	1.700	1.400 1.100	13,4	46,5 71,4	0,0311	1,3161 3,3313	2	14
260	630 x 30 710 x 30	2.600	1.100 950	27,5	78,4 96,6	0,1442	3,3863 5,4345	3	6
420	630 x 30 710 x 30	4.200	1.100 950	32,3	80,5 98,7	0,1677	3,3927 5,4409	3	10
550	630 x 30 710 x 30	5.500	1.100 950	42,4	86,6 104,8	0,2452	3,4177 5,4659	3	12
710	630 x 30 710 x 30	7.100	1.100 950	47,4	88,6 106,8	0,2941	3,4329 5,4811	3	15
1010	800 x 30 900 x 30	10.100	850 750	87,3	156,2 185,0	0,8730	9,2242 14,4515	4	9
1560	900 x 30	15.600	750	114,4	202,3	1,2090	14,6570	4	13

### ANTRIEBSMASCHINE

### DRIVE - R MACHINE

Hersteller / Type Manufacturer / Typ				
Nennleistung	$P_m$		kW	nominal input
Nenn Drehzahl	$n_m$		min <sup>-1</sup>	nominal speed
Wellen Ø	$d_m$		mm	shaft Ø
Nut (DIN 6885/1)	-		mm	keyway (DIN 6885/1)
Wellenlänge	$l_m$		mm	shaftlength
Nenn Drehmoment	$T_{m\text{ nenn}}$		Nm	nominal torque
max Anlauf Drehmoment	$T_m$		Nm	max starting torque
Massenträgheitsmoment	$J_m$		kg.m <sup>2</sup>	mass moment of inertia
max Drehmoment	$T_{m\text{ max}}$		Nm	max torque
Zahl der stündlichen Anläufe	$Z$		pro Std / per hr	number of starts/stops per hour
Belastung in 2 Drehrichtungen (ja / nein)				bidirectional load (yes / no)

### GETRIEBE

### GEARBOX

Hersteller / Type Manufacturer / Typ				
Nennübersetzung	$i$		-	nominal ratio
Nennleistung	$P_g$		kW	nominal power rating
Nenn Drehzahl	$n_g$		min <sup>-1</sup>	nominal speed
Wellen - Ø - Antrieb	$d_{g1}$		mm	shaft Ø - input
Nut (DIN 6885/1)	-		mm	keyway (DIN 6885/1)
Wellenlänge - Antrieb	$l_{g1}$		mm	shaftlength - input
Wellen - Ø - Abtrieb	$d_{g2}$		mm	shaft Ø - output
Nut (DIN 6885/1)	-		mm	keyway (DIN 6885/1)
Wellenlänge - Abtrieb	$l_{g2}$		mm	shaftlength - output
Nenn Drehmoment	$T_g$		Nm	nominal torque

### ABTRIEBSMASCHINE

### DRIVE - N MACHINE

Art System				
Hersteller / Type Manufacturer / Typ				
Nennleistung	$P_w$		kW	nominal output
Massenträgheitsmoment	$J_w$		kg.m <sup>2</sup>	mass moment of inertia
Nenn Drehzahl	$n_w$		min <sup>-1</sup>	nominal speed
Wellen Ø	$d_w$		mm	shaft Ø
Nut (DIN 6885/1)	-		mm	keyway (DIN 6885/1)
Wellenlänge	$l_w$		mm	shaftlength

### KUPPLUNG

### COUPLING

max axialer Wellenversatz	$DK_a$		mm	max axial shaft displacement
max radialer Wellenversatz	$DK_r$		mm	max radial shaft displacement
max winkliger Wellenversatz	$DK_w$		°	max angular shaft displacement
Umgebungstemperatur (min - max)	$T_{min} - T_{max}$	-	°C	ambient temperature (min - max)
Belastung (leicht / mittel / schwer)				shock load (small / moderate / heavy)
max Einbaulänge	$l_{1max}$		mm	max build-in length
max Einbau Ø	$d_{6max}$		mm	max build-in Ø
Radial ausbaubare Elemente (ja / nein)				radial mounting of elastic elements (yes / no)
Typgenehmigung (ja / nein)				type approval (yes / no)
Wuchten (ja / nein)				balancing (yes / no)
Material (GJL250 / GJS400 / Stahl / anders)				material (GJL250 / GJS400 / Steel / others)

### MONTAGEANLEITUNG

### A

### INSTALLATION INSTRUCTIONS

#### Allgemeine Montagehinweise

#### A.1

#### General Notes

Beachten Sie, daß während Montage oder Wartungsarbeiten die Anlage nicht unbeabsichtigt eingeschaltet werden kann. Nach dem Maschinenschutzgesetz muß der Käufer alle umlaufenden Maschinenteile gegen unbeabsichtigtes Berühren schützen. Zur Erleichterung der Montage können das Bolzen- und Büchsenteil kurzzeitig bis 150°C erwärmt werden. Das Bolzenteil mit montierten Gummielementen darf kurzzeitig bis 90°C erwärmt werden.

Prior to performing any installation or maintenance work (including inspections) it is essential that the power supply is isolated and that no movement is allowed of any rotating machinery. In order to comply with the laws regarding guarding of rotating parts, the buyer must ensure that adequate protection is provided over the coupling and other rotating parts. For easy assembly pin and bush parts can be heated up to 150°C maximum, without elements. The pin part, including elements, can be heated up to 90°C (during a short period).

#### Teilleiste VEBOFLEX-N

#### A.2

#### Part List VEBOFLEX-N

Pos	Bolzenteil	Anzahl	Bild 1. Einbauzeichnung VEBOFLEX-N	Pos	pin part	number
1	Welle	1			1	shaft
2	Schraube	Tabelle 2	2		bolt	Table 2
3	Stützscheibe	Tabelle 2	3		washer	Table 2
4	Stellschraube	1	4		set screw	1
5	Bolzenteil	1	5		pin part	1
6	Bolzen	Tabelle 2	6		pin	Table 2
7	Element	Tabelle 2	7		element	Table 2
8	Unterlegscheibe	Tabelle 2	8		washer	Table 2
9	Sicherungsring	Tabelle 2	9		retaining ring	Table 2
Pos	Büchsenteil	Anzahl	Figure 1. Assembly VEBOFLEX-N	Pos	pin part	number
10	Büchsenteil	1		10	bush part	1
11	Stellschraube	1		11	set screw	1
12	Welle	1		12	shaft	1

Tabelle 1. Teilleiste

Table 1. Part List

- Falls unmontiert, Elemente [7] auf Bolzen [6] montieren zusammen mit Unterlegscheiben [8] und Sicherungsringen [9].
- Falls Übergangs- oder Presspassung, Bolzenteil [5] und Büchsenteil [10] erwärmen.
- Bolzenteil [5] auf Welle [1] ziehen.
- Stellschraube [4] im Bolzenteil [5] anziehen.
- Büchsenteil [10] auf Welle [12] ziehen.
- Stellschraube [11] in Büchsenteil [10] anziehen.
- Abstand S1 laut Tabelle 4. überprüfen.
- Wellenversätze laut Tabelle 4. überprüfen.
- Falls unmontiert, Bolzen [6] in Bolzenteil [5] montieren zusammen mit Stützscheiben [3] und Schrauben [2].
- Schrauben [2] anziehen mit Momentschlüssel laut Tabelle 2.

- Mount, if necessary, the elements [7] onto pins [6] together with washers [8] and retaining rings [9].
- In case of transition or tight fit, heat up pin part [5] and the bush part [10].
- Mount pin part [5] onto shaft [1].
- Tighten set screw [4] in pin part [5].
- Mount bush part [10] onto shaft [12].
- Tighten set screw [11] in bush part [10].
- Check distance S1 according to Table 4.
- Check alignment according to Table 4.
- Mount, if necessary, pins [6] into pin part [5] together with washer [3] and bolts [2].
- Tighten bolts [2] according to Table 2.

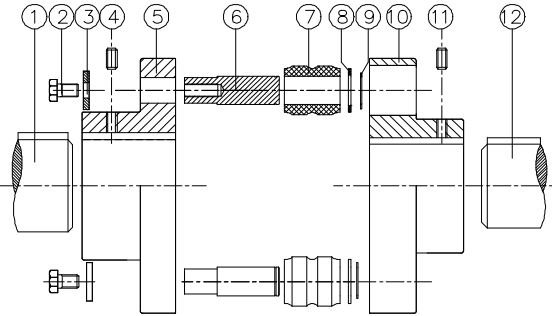
#### Bolzen

#### A.3

#### Pins

Größe	Bolzen größe	Anzahl Bolzen	Schraube DIN 933 / G 8.8	Anziehmoment der Schrauben	Größe	Bolzen größe	Anzahl Bolzen	Schraube DIN 933 / G 8.8	Anziehmoment der Schrauben
Size	[-] pin type	[-] number of pins	[-] bolt type DIN 933 / G 8.8	[Nm] tightening torque of the bolts	Size	[-] pin type	[-] number of pins	[-] bolt type DIN 933 / G 8.8	[Nm] tightening torque of the bolts
15	1	3	M 6 x 12	2,5	3820	5	16	M 12 x 35	60,0
26	1	5	M 6 x 12	2,5	4700	5	18	M 12 x 35	60,0
39	1	6	M 6 x 12	2,5	6500	6	10	M 16 x 45	125,0
58	1	9	M 6 x 12	2,5	8600	6	12	M 16 x 45	125,0
100	1	13	M 6 x 12	2,5	10500	6	14	M 16 x 45	125,0
130	2	11	M 6 x 16	3,0	12200	6	16	M 16 x 45	125,0
170	2	14	M 6 x 16	3,0	15200	7	10	M 24 x 60	510,0
260	3	6	M 8 x 20	12,0	17400	7	12	M 24 x 60	510,0
420	3	10	M 8 x 20	12,0	21000	7	12	M 24 x 60	510,0
550	3	12	M 8 x 20	12,0	27100	7	14	M 24 x 60	510,0
710	3	15	M 8 x 20	12,0	32300	7	16	M 24 x 60	510,0
1010	4	9	M 12 x 25	42,0	34900	7	16	M 24 x 60	510,0
1560	4	13	M 12 x 25	42,0	42300	7	18	M 24 x 60	510,0
2205	4	17	M 12 x 25	42,0	48300	7	18	M 24 x 60	510,0
3000	5	14	M 12 x 35	60,0	55200	7	20	M 24 x 60	510,0

Tabelle 2. Bolzen

Table 2. Pins

**! Die Schrauben müssen zusätzlich gesichert werden mit Loctite 243 !**

**! The bolts have to be additionally secured with Loctite 243 !**

### AUSRICHTHINWEISE

#### Position

Bei allen Bauformen muß der Abstand 'S1' (Bild 2.) eingehalten und gemessen werden und möglichst genau auf die in Tabelle 4. angegebenen Werte eingestellt werden (Meßuhr, Lineal, Schieblehre, Tiefenmaß).

Bild 2.  
Position S1

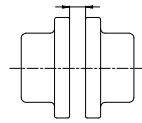

Figure 2.  
Position S1

### ALIGNMENT INSTRUCTIONS

#### Position

For all designs the distance between both hubs should be kept at 'S1' (Figure 2.) and has to be measured. It has to be adjusted - as exact as possible - to the value 'S1' as shown in table 4. (ruler, slide gauge, depth gauge, clock gauge).

#### Ausrichten

Nach der Montage sollen die radialen, axialen und winkligen Wellenversätze gemessen werden, mit Lasermeßgerät oder Meßuhr, Lineal, Meßschieber und Endmaßen. Die in Tabelle 4. angegebenen Werte für Ausrichttoleranzen sind als Richtwerte anzusehen, da das tatsächliche Ausgleichsvermögen der Kupplung sehr stark von der Drehzahl und der Belastung abhängt. Eine genaue Ausrichtung der Kupplungshälften erhöht die Lebensdauer der elastischen Kupplungselemente und Lager in der Anlage. Wir empfehlen, die Bolzen nach dem Ausrichten der Kupplungshälften zu montieren.

#### B.2

After installation the axial, radial and angular misalignment should be measured with laser or dial gauge, dial blocks and straightedge. It should be noted that the values in Table 4. should not be exceeded as the actual capability of the coupling to accommodate for misalignment is a function of the speed and the application. The greater the degree of accuracy of initial alignment the greater the length of trouble free life of the elastic elements and the bearings of the driver and driven machinery. We advise you to install the pins after alignment of the coupling half bodies.

Die aufgeführten Verlagerungswerte gelten bei Nenndrehmomente, stoßfreiem Betrieb, Drehzahl = 1.500 min<sup>-1</sup> und Umgebungstemperatur - 20°C bis + 80°C. Zulässiger Versatz ist ΔK<sub>r,zul</sub>·S<sub>n</sub> bzw. ΔK<sub>w,zul</sub>·S<sub>n</sub> (S<sub>n</sub> - Tabelle 3.). ΔK<sub>r</sub> und ΔK<sub>w</sub> können gleichzeitig auftreten. Die %-Summe der beiden vorhandenen Versätze ΔK<sub>r,vorh</sub> und ΔK<sub>w,vorh</sub> ist maximal 100%.

The listed displacement values apply at nominal torque, under shock-free operating conditions, nominal speed = 1.500 min<sup>-1</sup> and ambient temperatures - 20°C to + 80°C. Permissible displacement is ΔK<sub>r,zul</sub>·S<sub>n</sub> or ΔK<sub>w,zul</sub>·S<sub>n</sub> (S<sub>n</sub> - Table 3.). ΔK<sub>r</sub> and ΔK<sub>w</sub> could occur simultaneously. The %-sum of the two measured displacements ΔK<sub>r,vorh</sub> and ΔK<sub>w,vorh</sub> should not exceed 100%.

$$\frac{\Delta K_{r,vorh}}{\Delta K_{r,zul}} \times 100\% + \frac{\Delta K_{w,vorh}}{\Delta K_{w,zul}} \times 100\% \leq 100\%$$

ΔK<sub>r,zul</sub> / ΔK<sub>w,zul</sub> = zulässige Versätze (Tabelle 4.) / permissible displacements (table 4.)  
ΔK<sub>r,vorh</sub> / ΔK<sub>w,vorh</sub> = vorhandene Versätze / measured displacements

Drehzahl/Speed (min <sup>-1</sup> )	S <sub>n</sub>	axial / axial	radial / radial	winklig / angular
500	1,0			
1.000	1,0			
1.500	1,0			
2.000	0,8			
2.500	0,6			
3.000	0,4			

Tabelle /Table 3. Bild 3. Ausrichten Figure 3. Alignment

Größe Size	Abstand S1 distance	axial	radial	winklig	winklig	Größe Size	Abstand S1 distance	axial	radial	winklig	winklig
		DK <sub>a</sub> axial	DK <sub>r</sub> radial	DK <sub>w</sub> angular	DK <sub>w</sub> angular			DK <sub>a</sub> axial	DK <sub>r</sub> radial	DK <sub>w</sub> angular	DK <sub>w</sub> angular
		[mm]						[mm]			
15	2	± 1,0	0,5	± 0,35	0,33	3820	8	± 2,5	1,0	± 0,85	0,16
26	2	± 1,0	0,5	± 0,35	0,29	4700	8	± 3,0	1,0	± 0,85	0,14
39	2	± 1,0	0,5	± 0,35	0,27	6500	9	± 3,0	1,5	± 1,00	0,17
58	2	± 1,0	0,5	± 0,35	0,25	8600	9	± 3,0	1,5	± 1,00	0,16
100	2	± 1,0	0,5	± 0,35	0,21	10500	9	± 3,0	1,5	± 1,00	0,15
130	3	± 1,0	0,5	± 0,35	0,19	12200	9	± 3,0	1,5	± 1,00	0,14
170	3	± 1,0	0,5	± 0,35	0,19	15200	10	± 3,0	2,0	± 1,00	0,13
260	5	± 1,5	1,0	± 0,50	0,20	17400	10	± 3,0	2,0	± 1,00	0,12
420	5	± 1,5	1,0	± 0,50	0,19	21000	10	± 3,0	2,0	± 1,00	0,10
550	5	± 1,5	1,0	± 0,50	0,18	27100	10	± 3,0	2,0	± 1,00	0,10
710	5	± 2,0	1,0	± 0,50	0,17	32300	10	± 3,0	2,0	± 1,00	0,10
1010	6	± 2,0	1,0	± 0,65	0,18	34900	10	± 3,0	2,0	± 1,00	0,09
1560	6	± 2,0	1,0	± 0,65	0,17	42300	10	± 3,0	2,0	± 1,00	0,09
2205	6	± 2,5	1,0	± 0,65	0,15	48300	10	± 3,0	2,0	± 1,00	0,08
3000	8	± 2,5	1,0	± 0,85	0,17	55200	10	± 3,0	2,0	± 1,00	0,08

Tabelle 4. Position und Wellenversätze

Table 4. Position and Misalignment

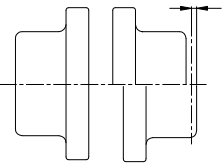
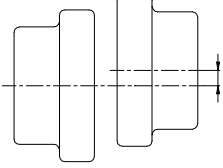
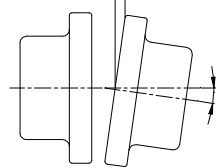
### WARTUNG

#### Allgemeine Wartungshinweis

Die VEBOFLEX-N Kupplungen sind wartungsfrei und bedürfen außer der kontinuierlichen Kontrolle und des Wechsels der Elemente keiner besonderen Pflege.

### C

### MAINTENANCE

#### C.1

#### General Maintenance Instructions

VEBOFLEX-N couplings are maintenance free and do not require any particular servicing except for continuous checking and replacement of the elements.

#### Wartung der Elementen und Bolzen

Die Elemente und Bolzen sollen kontinuierlich kontrolliert werden. Verschlossene Elemente und Bolzen sollen ersetzt werden durch VEBOFLEX-N Teile, damit die Drehsteifigkeit, Dämpfung und Temperaturbeständigkeit sich nicht ändert. Eine Verschiebung der Antriebs- und Abtriebseinheiten ist normalerweise nicht notwendig.

#### C.2

#### Maintenance of Elements and Pins

Periodically elements and pins should be checked for wear. Worn elements and pins should always be replaced by original VEBOFLEX-N parts, so that stiffness, damping and temperature resistance do not change. Displacement of drive-r and drive-n equipment is under normal conditions not necessary.