

WARNER ELECTRIC



Tension Control Systems

Tension Control Systems

WARNER ELECTRIC offers the most complete product line dedicated to the TENSION CONTROL MARKET. The long experience in the market led us to develop high performance controls able to operate in open and closed loop with brakes. **WARNER ELECTRIC** electromagnetic brakes find an optimum use in tension control when associated with the new digital control line.

ABOUT THIS CATALOGUE

This master catalogue groups all the solutions / products that WARNER ELECTRIC offers. An important part is dedicated to the solution design with particular consideration regarding the machine and the tension control installed. This should help you for the right solution choice taking in consideration the results you want to achieve. All the product characteristics and dimensions are included for every product.



Applying the appropriated Tension Control will lead you

- To improve quality of the operation
- To increase the production
- Finally to lower your production cost

CONTACT WARNER ELECTRIC FOR ANY ASSISTANCE YOU REQUIRE

www.warnerelectric-eu.com



	Pages
SYSTEM CONFIGURATIONS	4
System configuration 1	4
System configuration 2	4
System configuration 3	5
Open loop solutions	6
Closed loop solutions	7
TENSION CONTROL IN OPEN LOOP	8
I.a - Manual setting by pot.	8 - 9
I.b - Manual setting by following arm	8 - 9
II - Automatic setting by diameter reading	10-11
III - Automatic setting by diameter reading with additional functions	12-15
TENSION CONTROL IN CLOSED LOOP	16
I - Single roll tension control, automatic setting by dancer arm	16 - 21
II - Double roll tension control, automatic setting by dancer arm (modular)	22 - 23
III - Double roll or splicer tension control, automatic setting by dancer arm (compact)	24 - 25
IV - Double roll or splicer tension control, automatic setting by load cells	26 - 29
BRAKES AND CLUTCHES RANGE	30
Brakes and clutches models	30
ELECTROMAGNETIC BRAKE TYPE TB	32
Tension brake sizing	31
TB brake characteristics	32 - 35
Tension brake for strapping machine	36 - 37
MAGNETIC PARTICLE CLUTCHES AND BRAKES	38
MPB, MPC Series	38 - 45
BB, BC Series	46 - 68
MAGNETIC CLUTCHES AND BRAKES	69
MB, MC Series	69 - 75
Applications	76
DATA APPLICATION FORM	77
Tension selection	77
Data application form	78 - 79

System configurations

Analysing and preparing a project in tension control requires good analysis support. The general block diagrams below are a good representation of any machine generally supporting tension control. We recommend using these diagrams or a part of it in any discussion and correspondence in order to be clear and to avoid possible misunderstandings.

The tension area in an unwinding system is defined by places where we want to control this tension

SYSTEM CONFIGURATION 1

In single roll unwinding, we have one area tension between A and B. One brake can be easily installed in A. The brake control system selected will be according to the accuracy required: open loop or close loop.

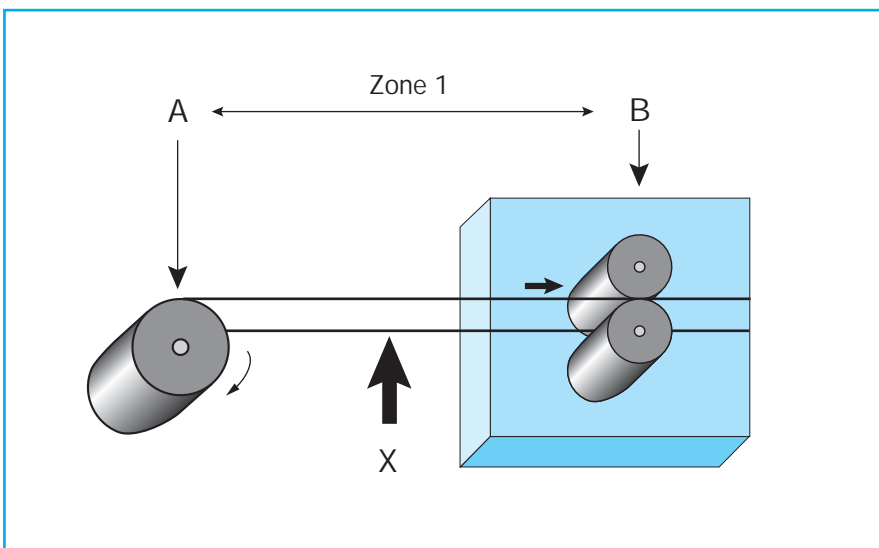

ZONE 1*, Typical characteristics (unwind)

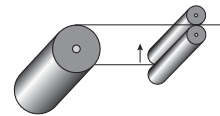

- Tension zone definition: A-B
- Speed point in B
- Variable roll rotation speed
- Variable inertia
- In general constant tension X
- Brake system applicable

SYSTEM CONFIGURATION 2

Most usual configuration with driving roll, a rewinder and an unwinder. 2 separate tension areas with tension could be different in X and in Y. Regarding accuracy required we will choose open loop or close loop.

In A, unwinding brake, in B motor for the speed and in C clutch or moto-reducer for rewinding.

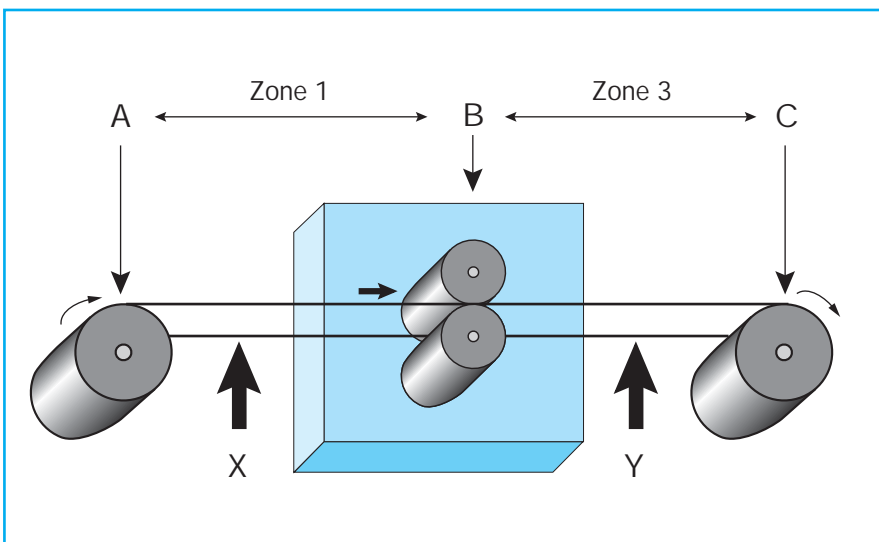

Zone 3*, Typical characteristics (rewind)

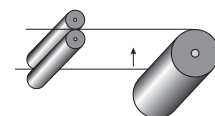

- Tension zone definition B-C
- Speed point in B
- Variable roll rotation speed
- Variable inertia
- Constant or Taper tension Z
- Particle brake system applicable

System configurations

SYSTEM CONFIGURATION 3

More complicated machine with intermediary tension area between winder and unwinder. The intermediary area give the line speed. A master-slave system with speed difference in area B/C give required tension.

All tension systems must be according the speed line in close loop.

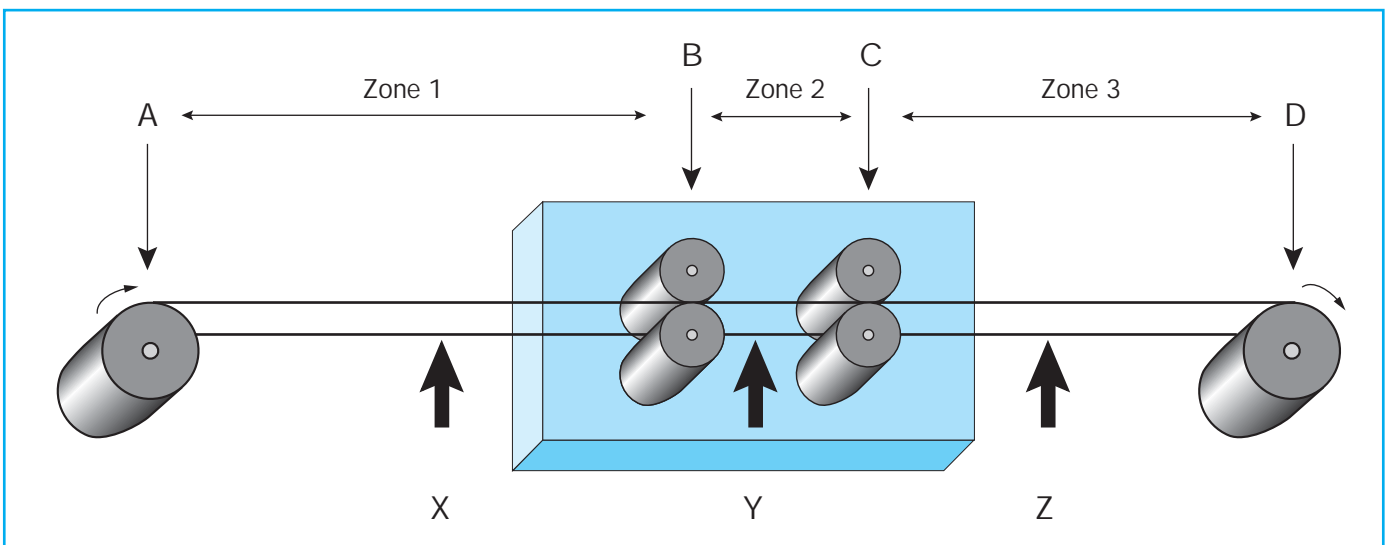

IMPORTANT CONSIDERATION

In every machine the speed point location must be clearly identified. In general one of driving nip roll is choose to set the linear speed. The machine speed is considered as **MASTER** function. The tension control, whatever the selected solution, works in **SLAVE** mode. Practically, the operator sets the machine speed with a simple potentiometer and all tension control system existing on the machine have to follow, keeping the required tension at any speed and during all transitory speed phases.

***NOTE :** Each zone is individually controlled. Tension may be different in each zone. It is assumed that there is no slipping on the nip roll.

ZONE 2*, Typical characteristics

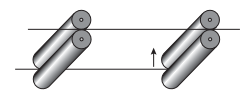

- Tension zone definition B-C
- Speed point in B or C
- Constant roll rotation speed
- Constant inertia
- In general constant tension Y
- Brake system applicable

System configurations

OPEN LOOP CONFIGURATION

Working in open loop requires an external reference setting applied to the driver. The torque applied to the unwind roll has to vary according to the diameter of the roll. We don't control acceleration, deceleration and emergency stop as the sensor is blind regarding the band tension.

Application needs one sensor only which drives an amplifier without return information for the influence of correction.



OPEN LOOP SOLUTION

Manual setting by pot.



Manual setting by following arm

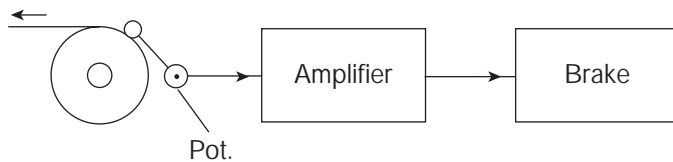

Automatic setting by diameter reading

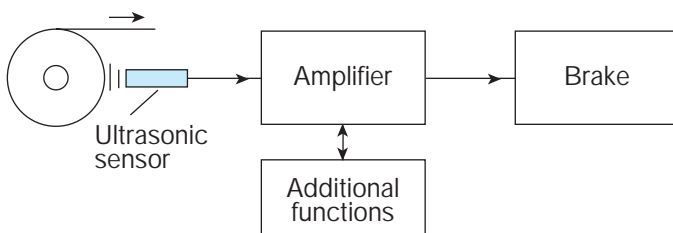

Automatic setting by diameter reading with additional functions

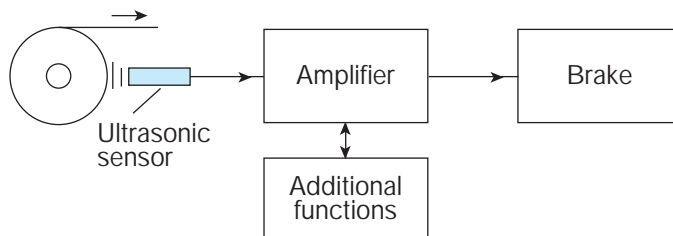

System configurations

CLOSED LOOP CONFIGURATION

Working in close loop needs one sensor. This one will measure directly or indirectly the band tension. Tension variations detected by sensor are sent to the brake through the control. This action corrects the variation and the new corrected sensor value is sent to the brake and so on.

Give an accurate tension regulation during acceleration, deceleration, emergency stop.



Position regulation by dancer arm

This is an electromechanical system and the building quality for the dancer arm must be verified. The band tension is created by the roll weight and/or by pneumatic actuator which have sensible air exhaust.

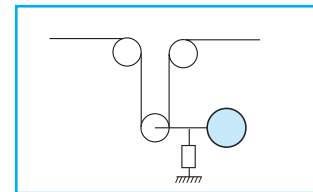

16 25

Regulation by load cell

This is an electromechanical system and the quality of load cells mounting must be checked. The band influences directly the load cells or load cells. The load cells choice and the mounting are very important regarding overload during starting or emergency stop.

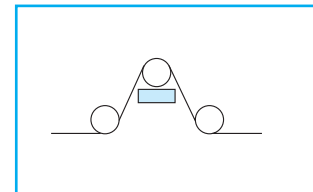

26 27

Splicer system regulation

Our control systems are used with double roll unwinders with splicer. The 2 brakes are always controlled, when one is in regulation, the other has holding function through numeric control range HMCS2000. These controls include loop control with PID, a lot of options and are able to be programmed by PC (via RS232 line) or by external programmer pocket (visual function).

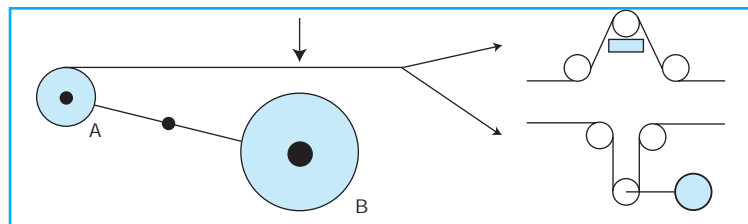

26 27

The PID function is optimised for one inertia value. The HMCS2000 line is inclusive of an important feature namely the PID correction. Based on the available diameter information you can apply a continuous PID correction. When no information is available, an internal PID change can be programmed.

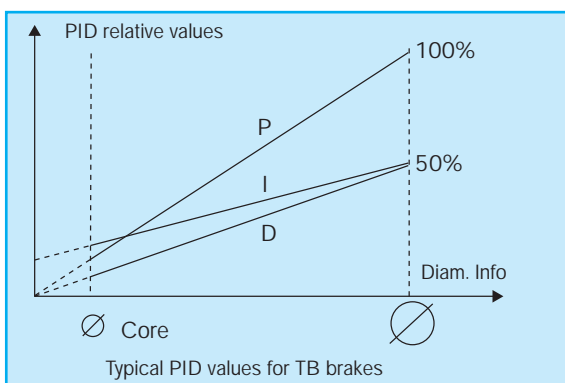

Each parameter P, I and D can be set individually for the smallest (core) and biggest diameter. As soon as the correct parameters are found for the extreme diameter value, they are stored. The diameter information provided will fix the PID values for the present diameter value. This will allow the system to keep an excellent stability during the whole diameter evolution. In the case where the diameter information is not available we can provide this signal by installing a sonic sensor or by working with internal correction. The external diameter information supplied to the controller will ensure a better precision compensation compared to an internal correction.

I - Tension control in open loop

Working in open loop requires that a torque setting is defined. The choice depends on the machine complexity and the automation required. One important factor that remains is the tension precision. For unwind and rewind systems the diameter ratio will play an important role. Working in open loop also requires special considerations regarding system inertia.

- a Manual setting by pot.
- b Manual setting by following arm

MAIN APPLICATIONS - ADVANTAGE

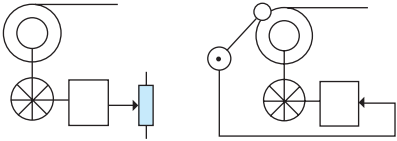
Setting type	Where, When, Why ?	Advantage
By Pot. Diameter reading 	<input type="checkbox"/> Cable machine <input type="checkbox"/> No fast accel/deccel <input type="checkbox"/> Low roll diameter ratio <input type="checkbox"/> Operator intervention admitted	<input type="checkbox"/> Low cost solution <input type="checkbox"/> Easy to start-up <input type="checkbox"/> Automatic regulation by diameter following arm <input type="checkbox"/> Manual correction feasible

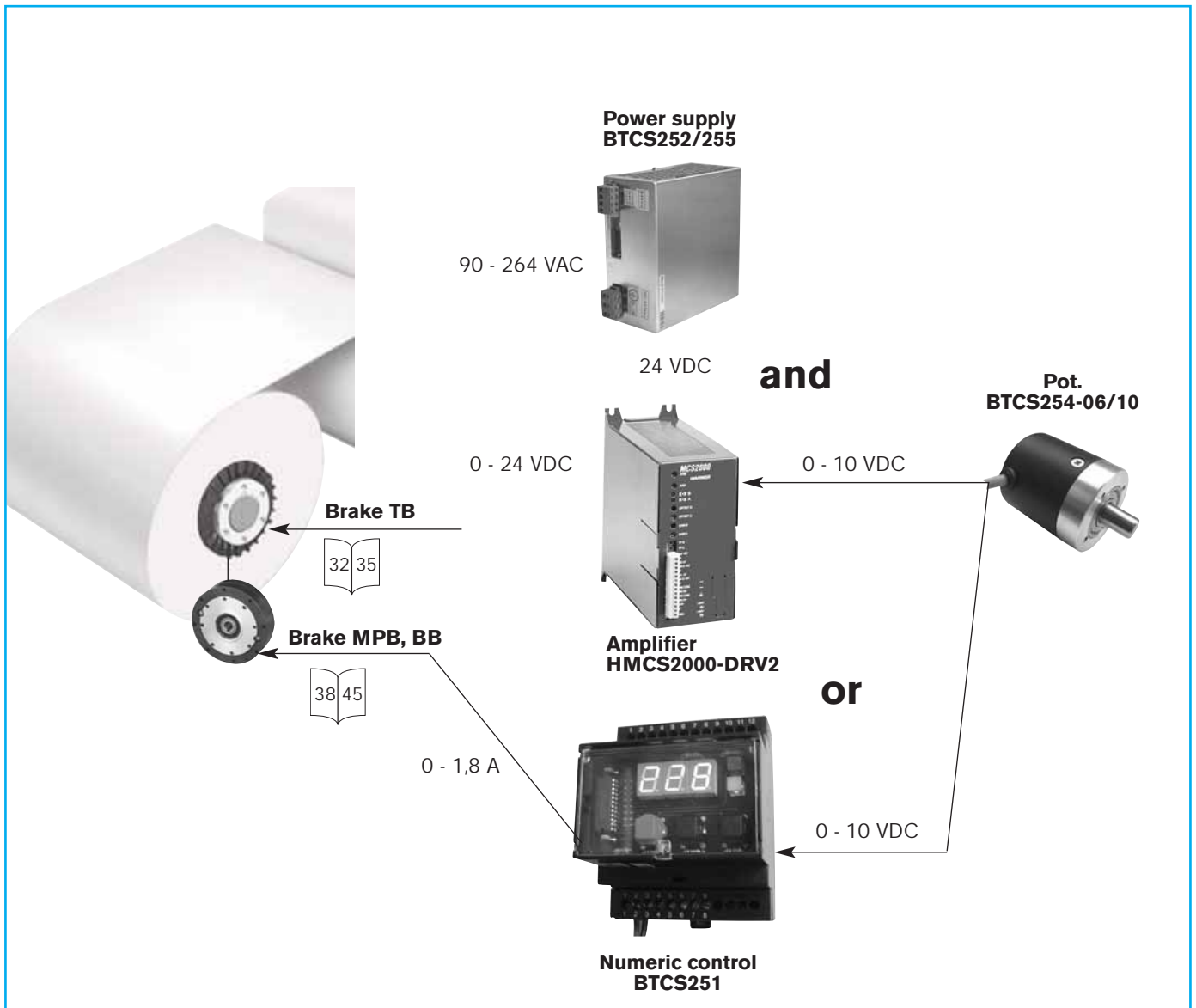

Manual setting by Pot.

Potentiometer BTCS254

With strong housing and axis with bearing, the potentiometer **BTCS254** is suitable for open or closed loop applications.

BTCS254-06	6 mm axis
BTCS254-10	10 mm axis
Potentiometer	10 k Ohm
Shaft material	Stainless steel AISI3003
Cover material	Plastic reinforced with glass fibre
Body material	Alu UNI 9002/5
Protection	Standard IP54
Operating temperature	0°C / +60°C
Cable length	1,5 m
Weight	150 g
Service manual	MC554

Dimensions (mm)

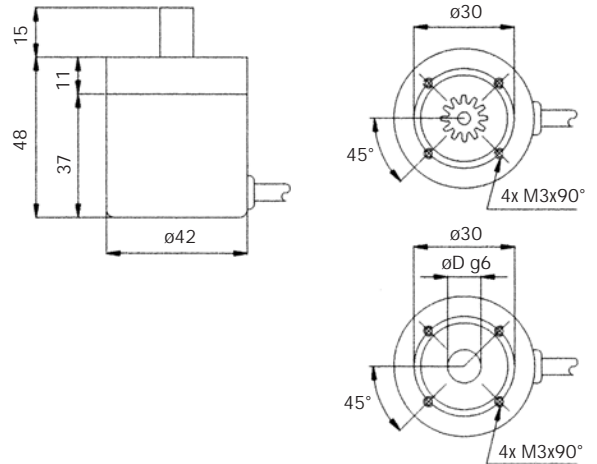

BTCS 252/255 - Single phase power supply / 24 VDC

The Warner Electric switching power supply units of the BTCS252 series are designed and developed for industrial uses where safety, ease of use and reliability are essential. These units comply with the parameters set out by the Low Voltage Directive.

The low working temperature at full power operating temperature combined with the use of first quality components ensure high reliability and duration.

Specifications

Input	90-264 VAC / 110 VDC, 50/60 Hz
Output	24 VDC, 3 A (BTCS252) and 5 A (BTCS255)
Service manual	MC550

Dimensions (mm)

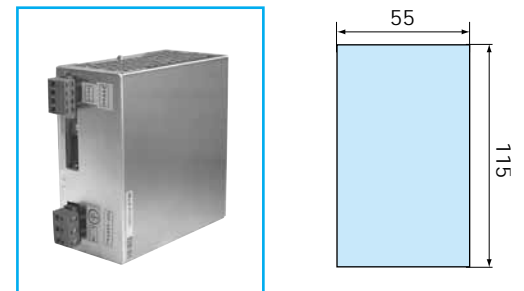

ELECTRICAL AMPLIFIER HMCS2000

HMCS2000-DRV2

□ 1 logic card with 2 individual channels

Model	Electrical input signal	Power supply / current	Output voltage / current
HMCS2000-DRV2	0 – 10 VDC	24/48 VDC	0-24/48 VDC/4,5 A
Wiring	Shielded cable		
Setting	Anti-residual		
Mounting position	Vibrations free, vertically		
Service manual	MC517		

Dimensions (mm)

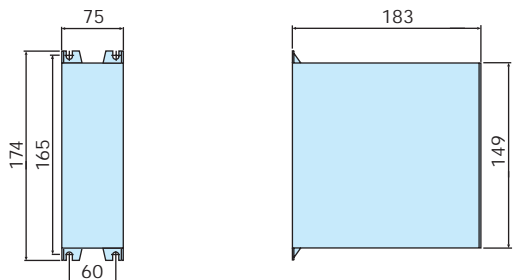

NUMERIC CONTROL BTCS251 (see page 17)

Service manual, mounting with Pot. : SM563

II - Tension control in **open loop**

MAIN APPLICATIONS - ADVANTAGE

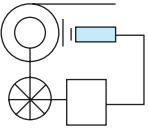
Setting type	Where, When, Why ?	Advantage
Diameter reading 	<ul style="list-style-type: none"> <input type="checkbox"/> The most commonly used solution in open loop <input type="checkbox"/> No operator intervention admitted <input type="checkbox"/> Large roll \varnothing ratio 	<ul style="list-style-type: none"> <input type="checkbox"/> Physical reading, no reset <input type="checkbox"/> Easy to start-up

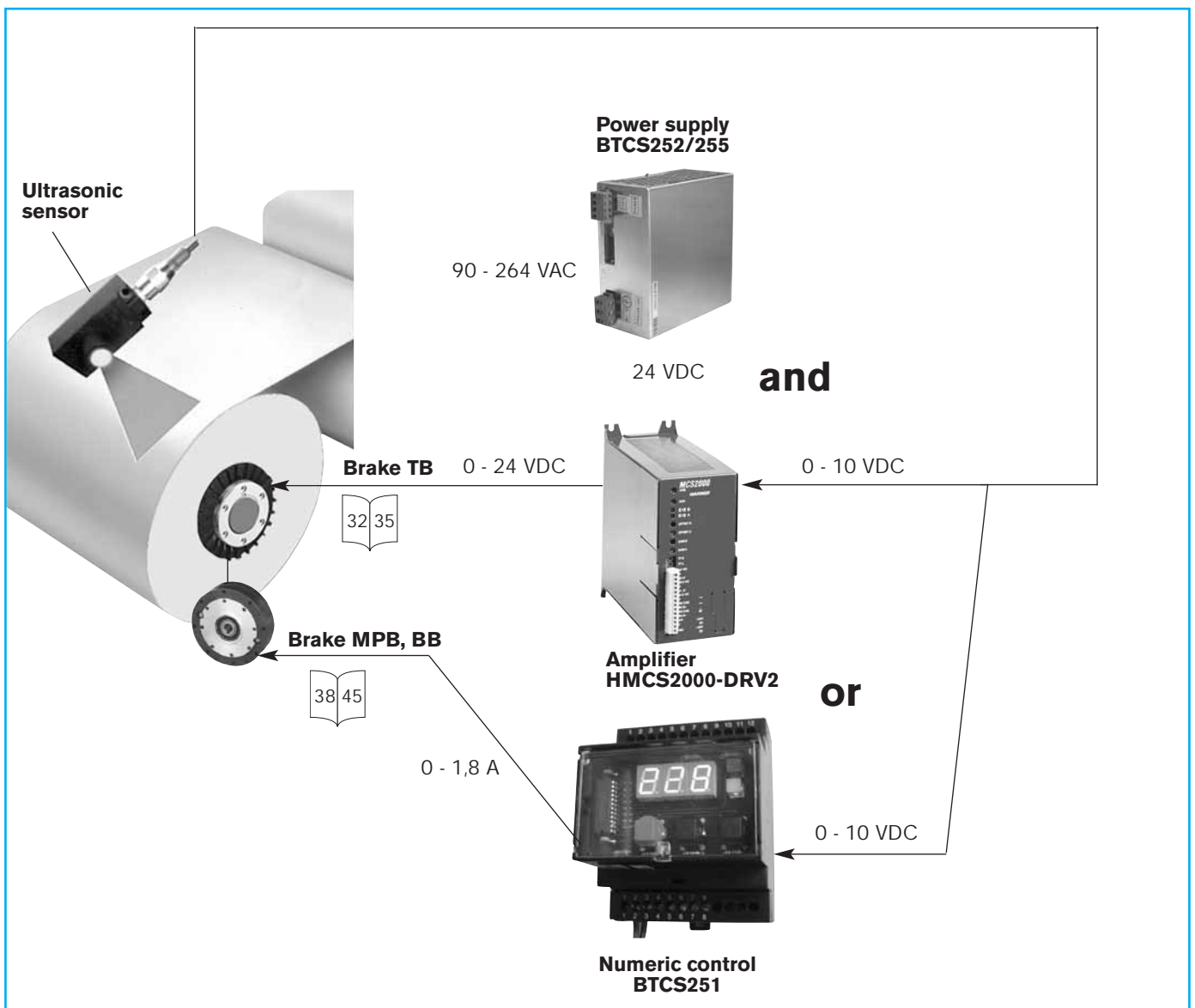

Automatic setting by diameter reading

ULTRASONIC SENSORS

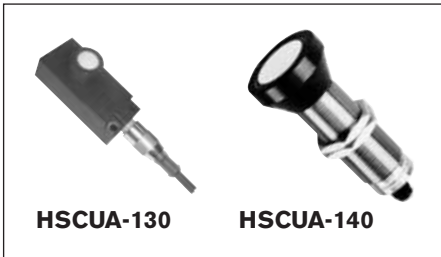

Model	HSCUA-130	HSCUA-140
Power supply	15 to 30 VDC / max 30 mA	15 to 30 VDC / max 30 mA
Min. distance	100 mm	400 mm
Max. distance	900 mm	2400 mm
Accuracy	±1 mm	±1 mm
Protection class	IP67	IP67
Accessory	5 m cable	5 m cable
Service manual	MC487	MC488

Dimensions (mm)

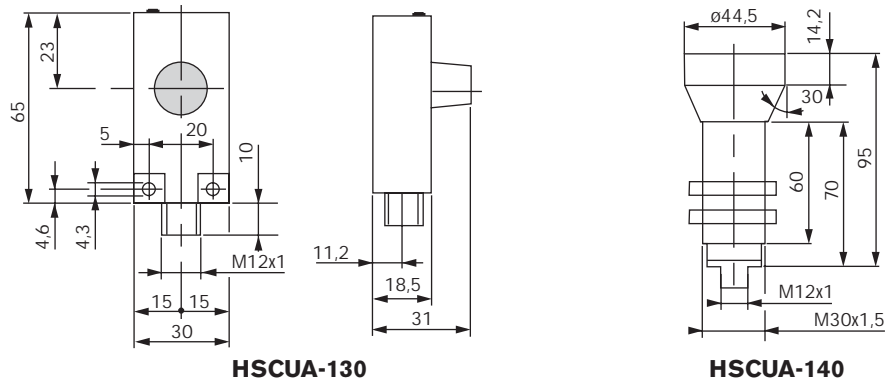

BTCS 252/255 - Single phase power supply / 24 VDC

The Warner Electric switching power supply units of the BTCS252 series are designed and developed for industrial uses where safety, ease of use and reliability are essential. These units comply with the parameters set out by the Low Voltage Directive.

The low working temperature at full power operating temperature combined with the use of first quality components ensure high reliability and duration.

Specifications

Input	90-264 VAC / 110 VDC, 50/60 Hz
Output	24 VDC, 3 A (BTCS252) and 5 A (BTCS255)
Service manual	MC550

Dimensions (mm)

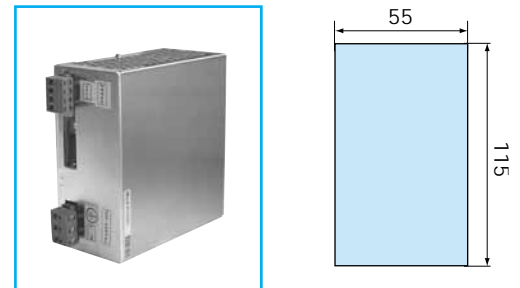

ELECTRICAL AMPLIFIER HMCS2000

HMCS2000-DRV2

□ 1 logic card with 2 individual channels

Model	Electrical input signal	Power supply / current	Output voltage / current
HMCS2000-DRV2	0 – 10 VDC	24/48 VDC	0-24/48 VDC/4,5 A
Wiring	Shielded cable		
Setting	Anti-residual		
Mounting position	Vibrations free, vertically		
Service manual	MC517		

Dimensions (mm)

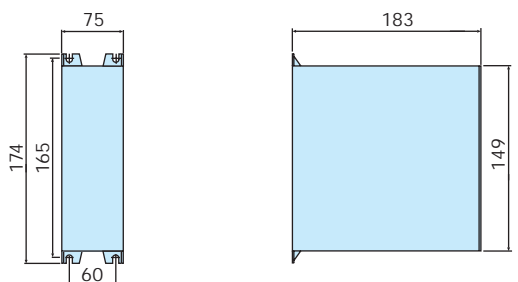

NUMERIC CONTROL BTCS251 (see page 17)

Service manual, mounting with ultrasonic sensor : SM564

III - Tension control in **open loop**

MAIN APPLICATIONS - ADVANTAGE

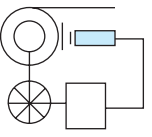
Setting type	Where, When, Why ?	Advantage
Diameter reading 	<ul style="list-style-type: none"> <input type="checkbox"/> The most commonly used solution in open loop <input type="checkbox"/> Operator intervention admitted <input type="checkbox"/> Large roll \varnothing ratio 	<ul style="list-style-type: none"> <input type="checkbox"/> Physical reading, no reset <input type="checkbox"/> Easy to start-up <input type="checkbox"/> Graphic display for output percentage value <input type="checkbox"/> Functions control available remote/ manually by operator

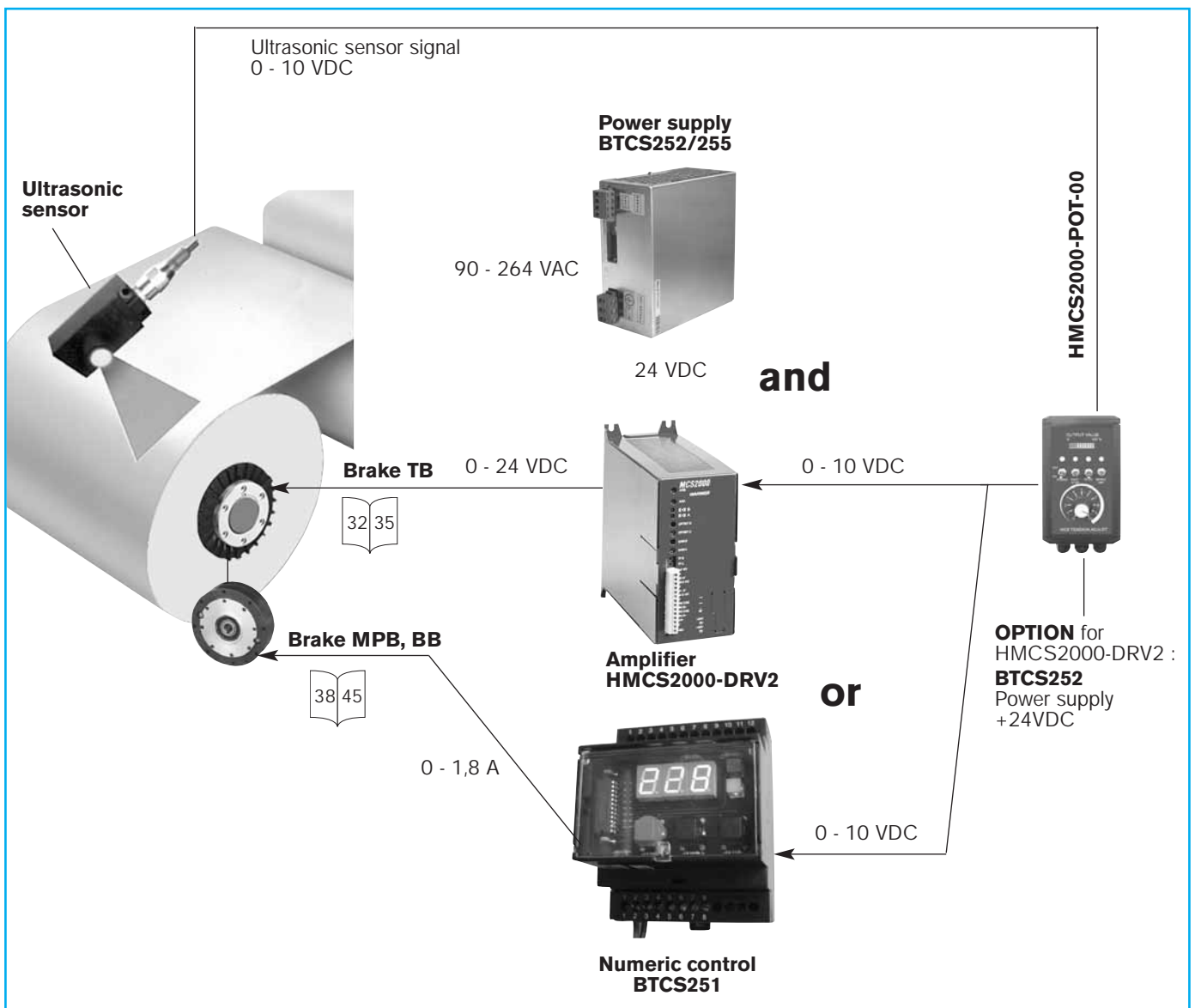

Automatic setting by diameter reading

Ultrasonic sensors - Dimensions, see page 11

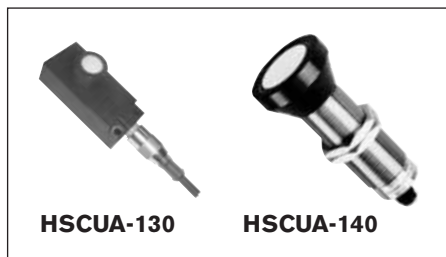

Model	HSCUA-130	HSCUA-140
Power supply	15 to 30 VDC / max 30 mA	15 to 30 VDC / max 30 mA
Min. distance	100 mm	400 mm
Max. distance	900 mm	2400 mm
Accuracy	±1 mm	±1 mm
Protection class	IP67	IP67
Accessory	5 m cable	5 m cable
Service manual	MC487	MC488

Ultrasonic Diameter Sensing – HMCS2000-POT-00

- ❑ A simple, analogue, open loop torque control.
- ❑ Power supply 24 VDC / Internal consumption 150 mA.
- ❑ Adjustable maximum level of the output signal relatively to the ultrasonic input level.
- ❑ Graphic display of the output level – full screen equal 10 VDC.
- ❑ FAST STOP, HOLD and BRAKE OFF can be activated either through the front switches or through the terminal bloc.
- ❑ FAST STOP and HOLD levels are adjustable via potentiometer.
- ❑ FAST STOP: a ratio of 1 to 10 times to OPERATING LEVEL
- ❑ OPERATING LEVEL: maximum 10 VDC divided by the FAST STOP ratio.
- ❑ HOLD: output level adjustable between 0 and 10 VDC

To be used ONLY with scalable ultrasonic sensors type HSCUA-130 (0,9 m) or HSCUA-140 (2,5 m)

- ❑ Service manual : MC520



Mounting and dimensions (mm)

Overall dimensions maximum:

Height	160 mm
Width	95 mm
Depth	75 mm
Weight	0,350 kg

ELECTRICAL AMPLIFIER HMCS2000

HMCS2000-DRV2

- ❑ 1 logic card with 2 individual output channels

Model	Electrical input signal	Power supply / current	Output voltage / current
HMCS2000DRV2	0 – 10 VDC	24/48 VDC	0-24/48 VDC/4,5 A
Wiring	Shielded cable		
Setting	Anti-residual		
Mounting position	Vibrations free, vertically		
Service manual	MC517		

Dimensions (mm)

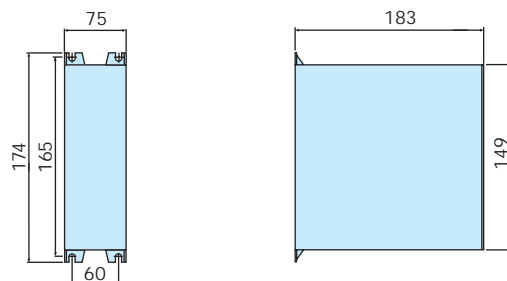

POWER SUPPLY BTCS252/255 (see page 15)

NUMERIC CONTROL BTCS251 (see page 17)

Service manual, mounting with 0-10 V signal : SM571

III - Tension control in open loop

MAIN APPLICATIONS - ADVANTAGE

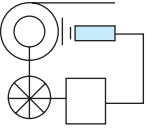
Setting type	Where, When, Why ?	Advantage
Diameter reading 	<ul style="list-style-type: none"> <input type="checkbox"/> The most commonly used solution in open loop <input type="checkbox"/> Operator intervention admitted <input type="checkbox"/> Large roll ϕ ratio 	<ul style="list-style-type: none"> <input type="checkbox"/> Physical reading, no reset <input type="checkbox"/> Easy to start-up <input type="checkbox"/> Particle brake current controlled <input type="checkbox"/> Cheaper solution

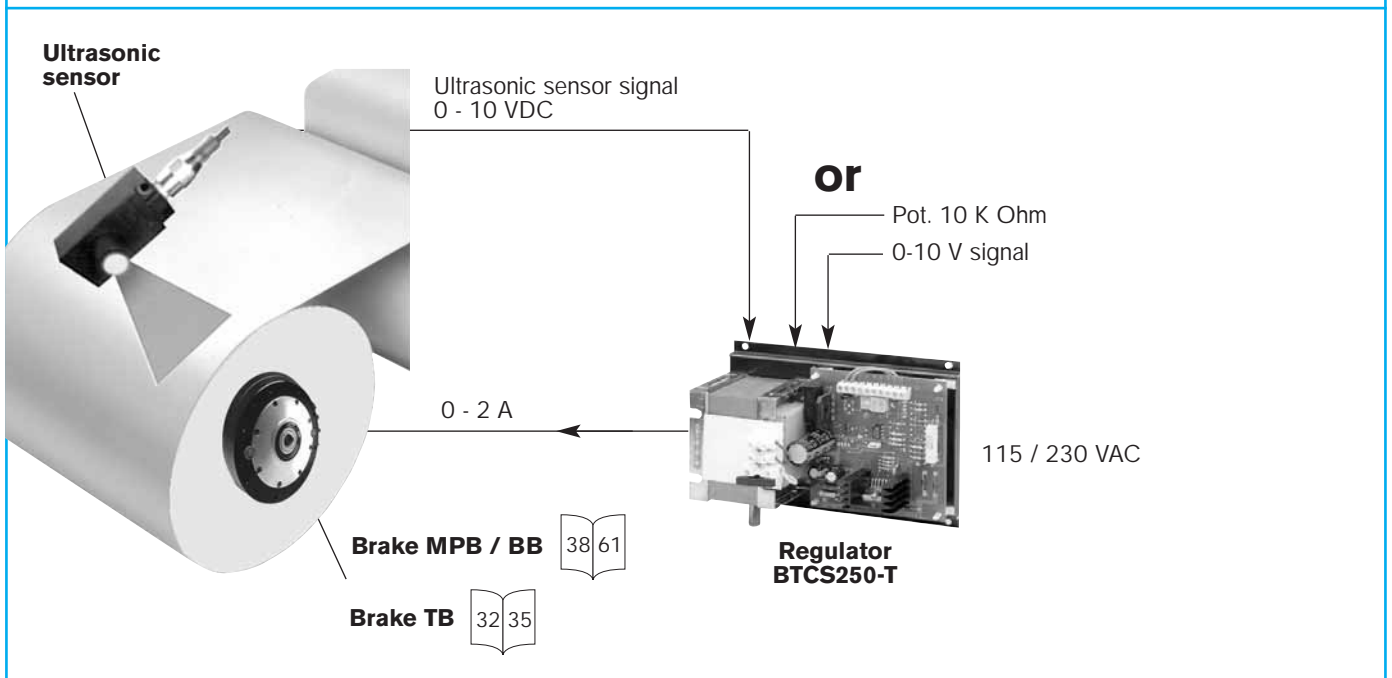
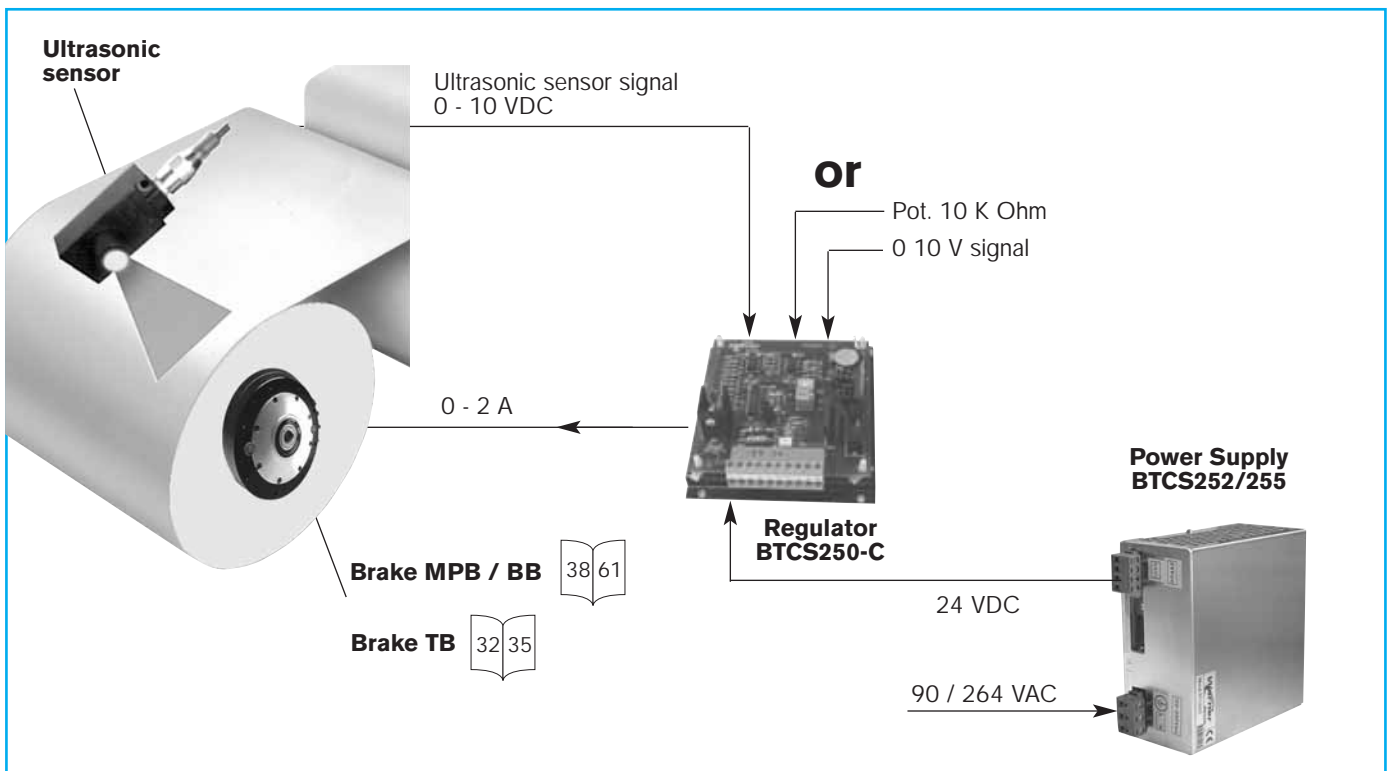

Automatic setting by diameter reading

Ultrasonic sensors - Dimensions, see page 11

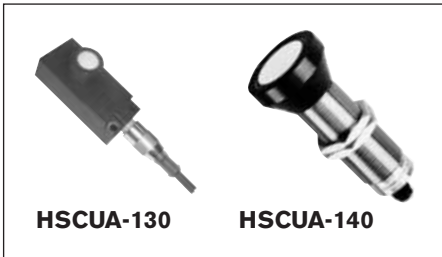

Model	HSCUA-130	HSCUA-140
Power supply	15 to 30 VDC / max 30 mA	15 to 30 VDC / max 30 mA
Min. distance	100 mm	400 mm
Max. distance	900 mm	2400 mm
Accuracy	±1 mm	±1 mm
Protection class	IP67	IP67
Accessory	5 m cable	5 m cable
Service manual	MC487	MC488

BTCS 250 - Current regulator power supply for particle brakes

The BTCS250 card was designed especially for controlling particle brakes and for increasing their yield. In fact, this permits complete elimination of residual magnetism in the powder and therefore it is possible to work in low torque ranges without limits.

The components used are professional type and this assures absolute reliability over time. Its limited size facilitates wall mounting.

Connection is easy and is done via 10-pole connector fastened to the terminals with screws.

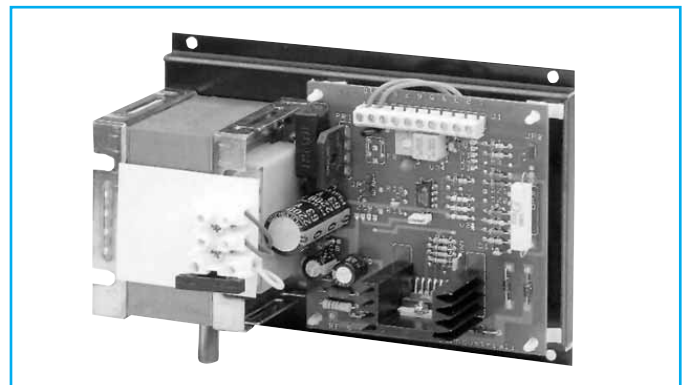

Specifications

Power supply BTCS250-C	28 VAC or 24 VDC
Power supply BTCS250-T	110/230 VAC 50/60 Hz
Input	0-10 VCC from Pot. 10K
Output	0-2 A modulated PWM
BTCS250-C	Only card
BTCS250-T	Card with transformer
Service manual	MC544

Dimensions (mm)

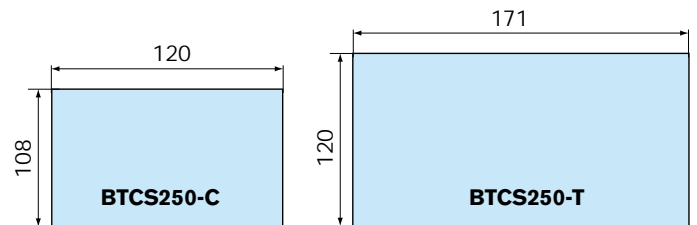

BTCS 252/255 - Single phase power supply / 24 VDC

The Warner Electric switching power supply units of the BTCS252 series are designed and developed for industrial uses where safety, ease of use and reliability are essential. These units comply with the parameters set out by the Low Voltage Directive.

The low working temperature at full power operating temperature combined with the use of first quality components ensure high reliability and duration.

Warner Electric switching power supply units comply with EMI standards. The BTCS252 series with 90 – 264 VAC input has no ignition problems at full load even with low mains voltage and therefore suitable for critical supply mains. This series very compact and has an IP 20 degree of protection against incidental contacts according to IEC 529. All the functions are located on the front panel and marked with IEC symbols.

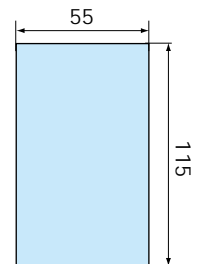

Specifications

Input	90-264 VAC / 110 VDC, 50/60 Hz
Output	24 VDC, 3 A (BTCS252) and 5 A (BTCS255)
Service manual	MC550

I - Tension control in closed loop

BTCS251 is a digital controller that can be used in both open or closed loop. The brake driver is included and supply current regulation especially for powder brakes. One 3 digit display permit to follow signal variations.

MAIN APPLICATIONS - ADVANTAGE

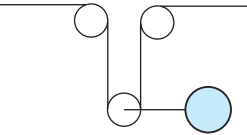
Setting type	Where, When, Why ?	Advantage
Dancer arm 	<ul style="list-style-type: none"> <input type="checkbox"/> Unwinders <input type="checkbox"/> Printing machines <input type="checkbox"/> Intermittent or continuous function <input type="checkbox"/> Adapted to powder brakes 	<ul style="list-style-type: none"> <input type="checkbox"/> Output PWM included <input type="checkbox"/> Digital inputs <input type="checkbox"/> Numeric with micro-processor <input type="checkbox"/> Accel / decel machine with separated PID <input type="checkbox"/> Can drive motor or pneumatic brake

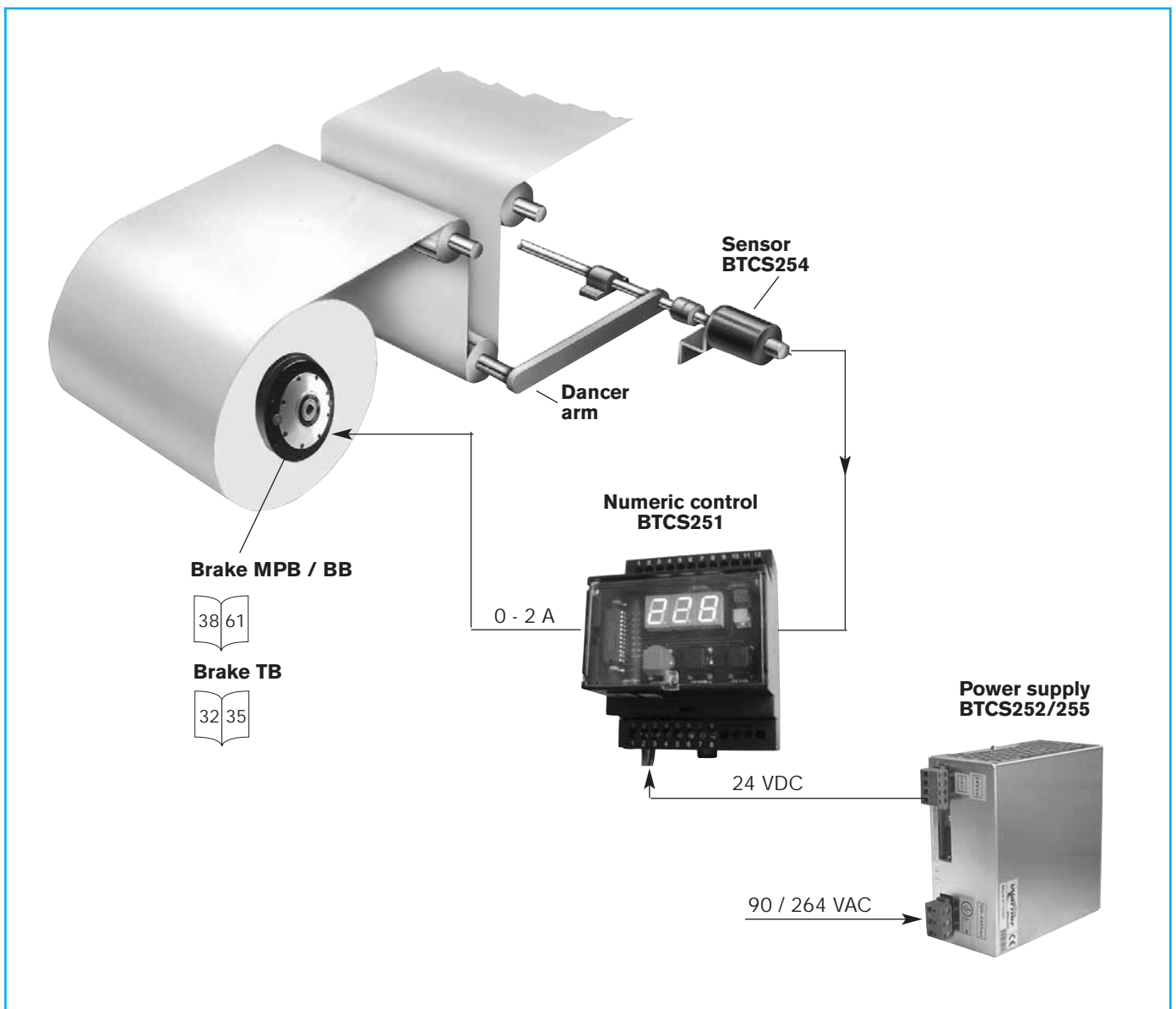

Automatic setting by dancer arm

BTCS251 - Numeric control

This device integrates a microprocessor control function and the power output to control the electromagnetic powder brakes.

Equipped with only 3 push buttons for calibration and programming and one display with a 3 digit reading, it has been designed to be mounted on a DIN rail inside customers electrical control panel.

The compact size, simple installation and easy to use make the instrument extremely flexible.

The 24 VDC digital inputs can be easily interfaced with the instrumentation running the machine logic (PLC). The type of input and output electrical signals can be chosen via a keyboard by the system designer and the P.I.D. control logic results in high performance precision control.

The unit has been designed specifically for machines utilising a dancer roll and magnetic particle brake however it can also be used with pneumatic brakes or motors, on unwind or rewind applications and with amplified load cells.



Spécifications

Supply	24 VDC / 18 VCA
Power with particle brake:	50 W max.
Power with pneumatic brake or motor:	6 W max.
Regulated analog output	0-10V/-5+5V/4-20 mA selectable via keyboard
Analog output	0-10V
PWM output	24VDC, 1,8 A max
Analog input keyboard selection	0-5V/0-10V/0-20 mA
Digital input	24 VDC
Working temp.	0-50 °C
Weight	180 g
Standard approval	CE/UL
Mounting	Rail DIN
Service manual	MC553

Applications

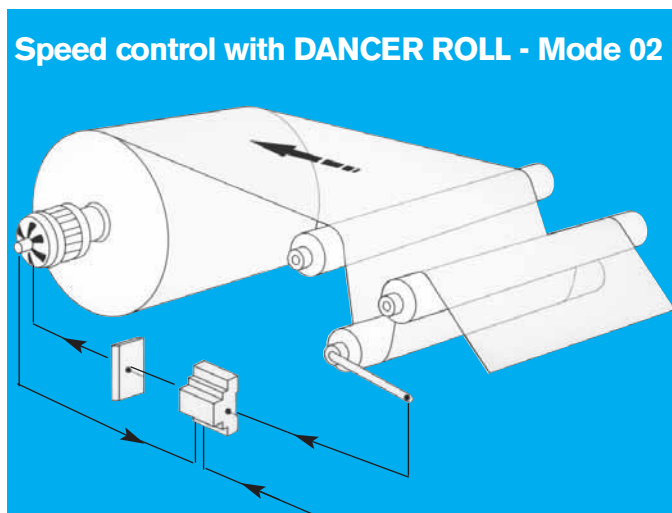
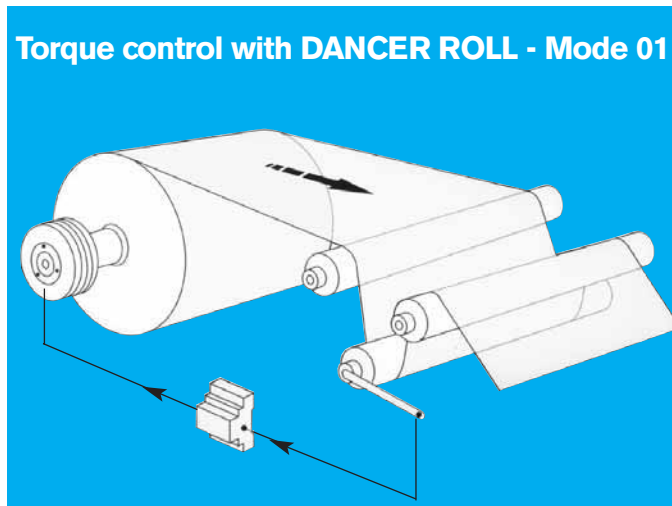

Dimensions

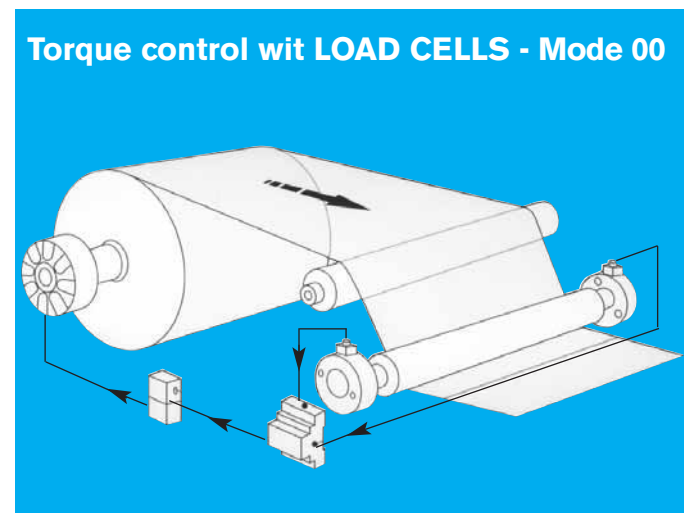
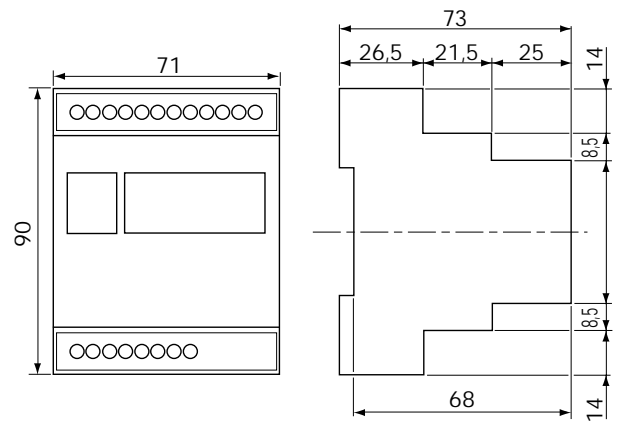

I - Simple tension control in closed loop

If your machine requires a very accurate web tension control, then you need to work in closed loop. An important unit in the loop is the sensor. Several possibilities are offered. The choice now depends on the kind of machine you are building, the mechanical construction and the max tension value you desire to control.

MAIN APPLICATIONS - ADVANTAGE

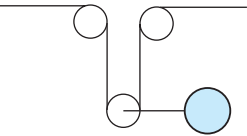
Setting type	Where, When, Why ?	Advantage
Dancer arm 	<ul style="list-style-type: none"> <input type="checkbox"/> Printing machines <input type="checkbox"/> Intermittent function <input type="checkbox"/> Flying splice need 	<ul style="list-style-type: none"> <input type="checkbox"/> Absorb tension peak <input type="checkbox"/> Can act as store <input type="checkbox"/> Easy flying splice <input type="checkbox"/> Accel / decel machine phase well absorbed <input type="checkbox"/> Flexibility

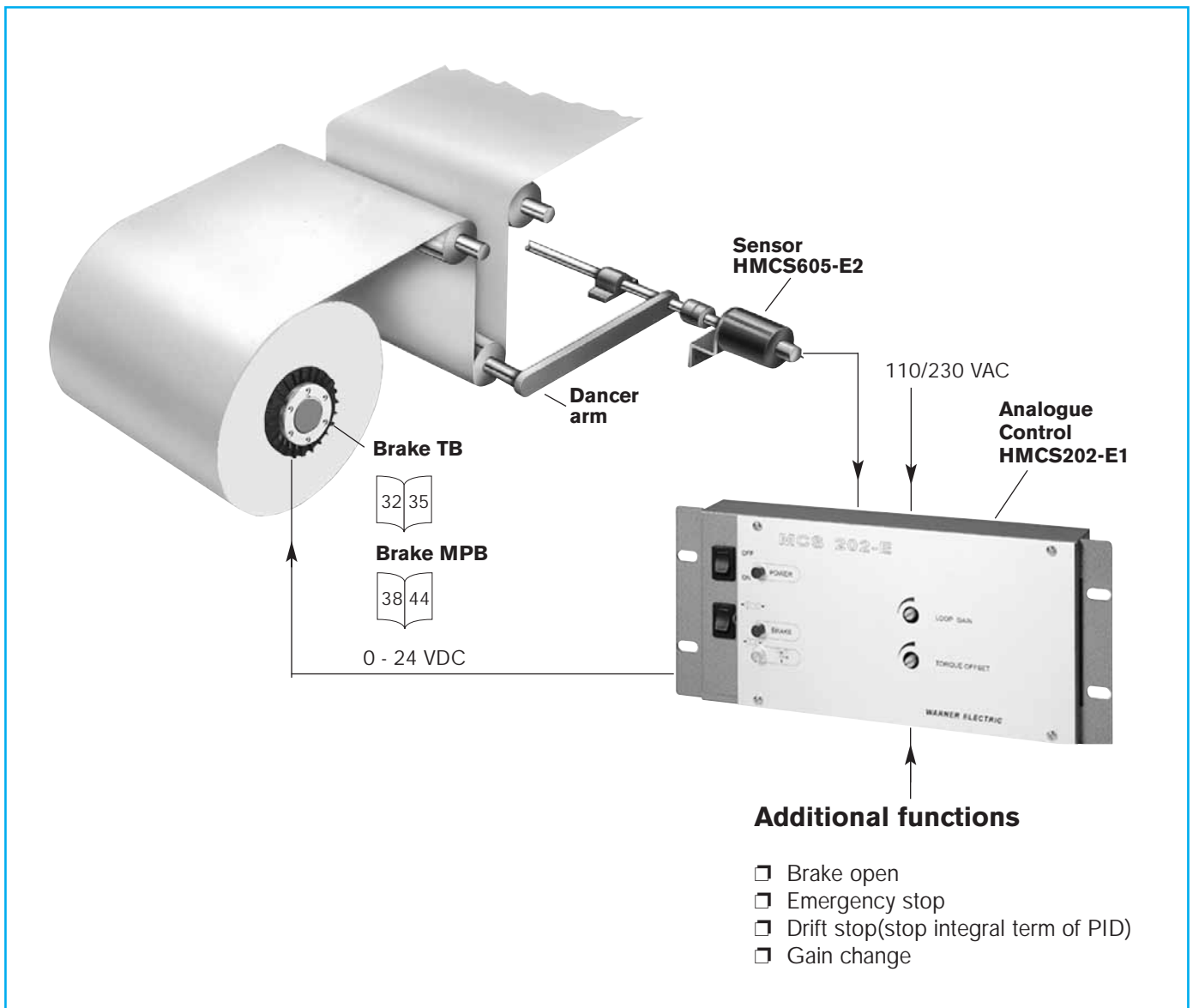

Automatic setting by dancer arm

ROTARY SENSOR HMCS605-E2 (see pages 20 and 21)

ANALOGUE CONTROL HMCS202-E1

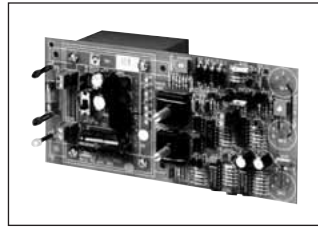

- HMCS202-E1** Standard execution
- HMCS202-E54** Standard IP54 protected
- HMCS202-EC1** Open frame execution

Technical characteristics – valid for 3 executions

	Range - Values	Comments
Power supply	110-220 VAC selectable	Open front face to access
Output current capability	Max 2, 5 Amps, short circuit protected	Able to power 2 TB in parallel
User settings	Loop gain	Front face potentiometer
	Offset torque	Front face potentiometer
Output voltage brakes	0-24 VDC	Compatible all elec. Warner Electric
Housing	Metal rugged housing	Only HMCS202-E1 and –E54
Loop gain	2 adjustable range selection	Can be change during operation
Accessories	HMCS-KIT1, 2, 3, 5 and 6	See details on page 21
Sensor compatible	Dancer arm with HMCS605-E2	See details on pages 20 and 21
Service manual	MC403	

Technical information

HMCS202 control is based on classical and fixed PID terms. The loop gain can be set on front face potentiometer. Due to the fixed PID terms, its use is limited in terms of roll diameter ratio. One input is provided to change the loop gain and has to be used when diameter ratio exceeds 8. To ensure proper operation it is important to wire the function "Drift Stop". This function releases the Integral term as soon as the machine runs.

Dimensions (mm)

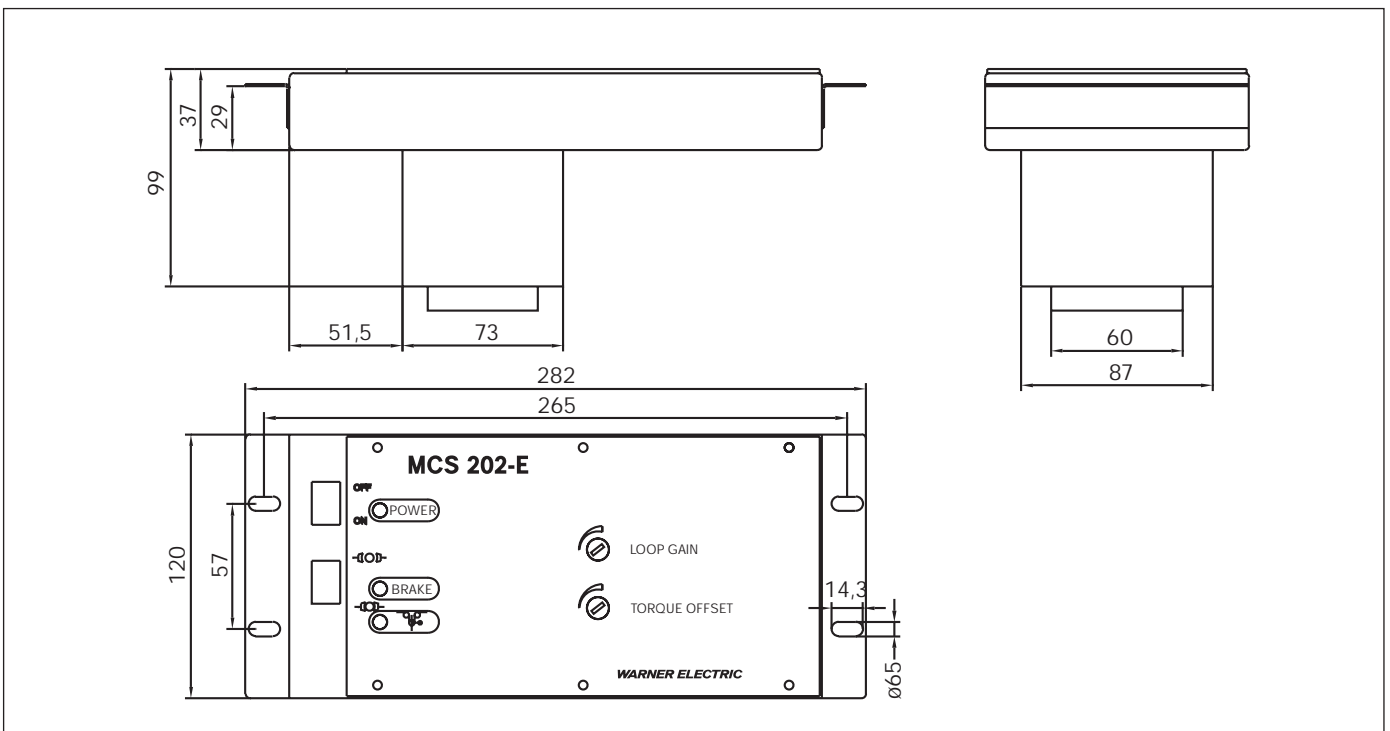

Automatic setting by dancer arm

ROTARY SENSOR HMCS605-E2

A position sensor is used in 2 possible ways:

- To detect dancer moving in the closed loop installation working on dancer principle.
- To sense the diameter of the roll to operate open loop control or make PID compensation in closed loop installation.

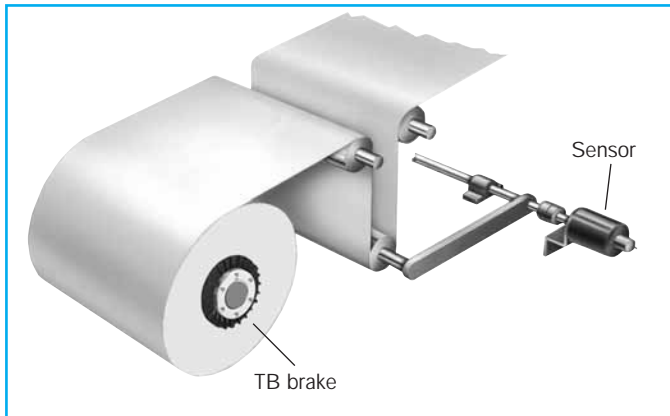

HMCS605-E2 is ideal for easy mounting. It is encapsulated in rugged metal housing preventing mechanical shocks. Furthermore it is provided with built in switch in order to change the signal output polarity.

	HMCS605-E2
Power supply	10 to 30 VDC / 30 mA (or ± 5 to 15 VDC)
Max. detection angle	200° or $\pm 100^\circ$
Sensitivity	2,5 mV / V / °
Service manual	MC483

Dimensions (mm) - Mounting

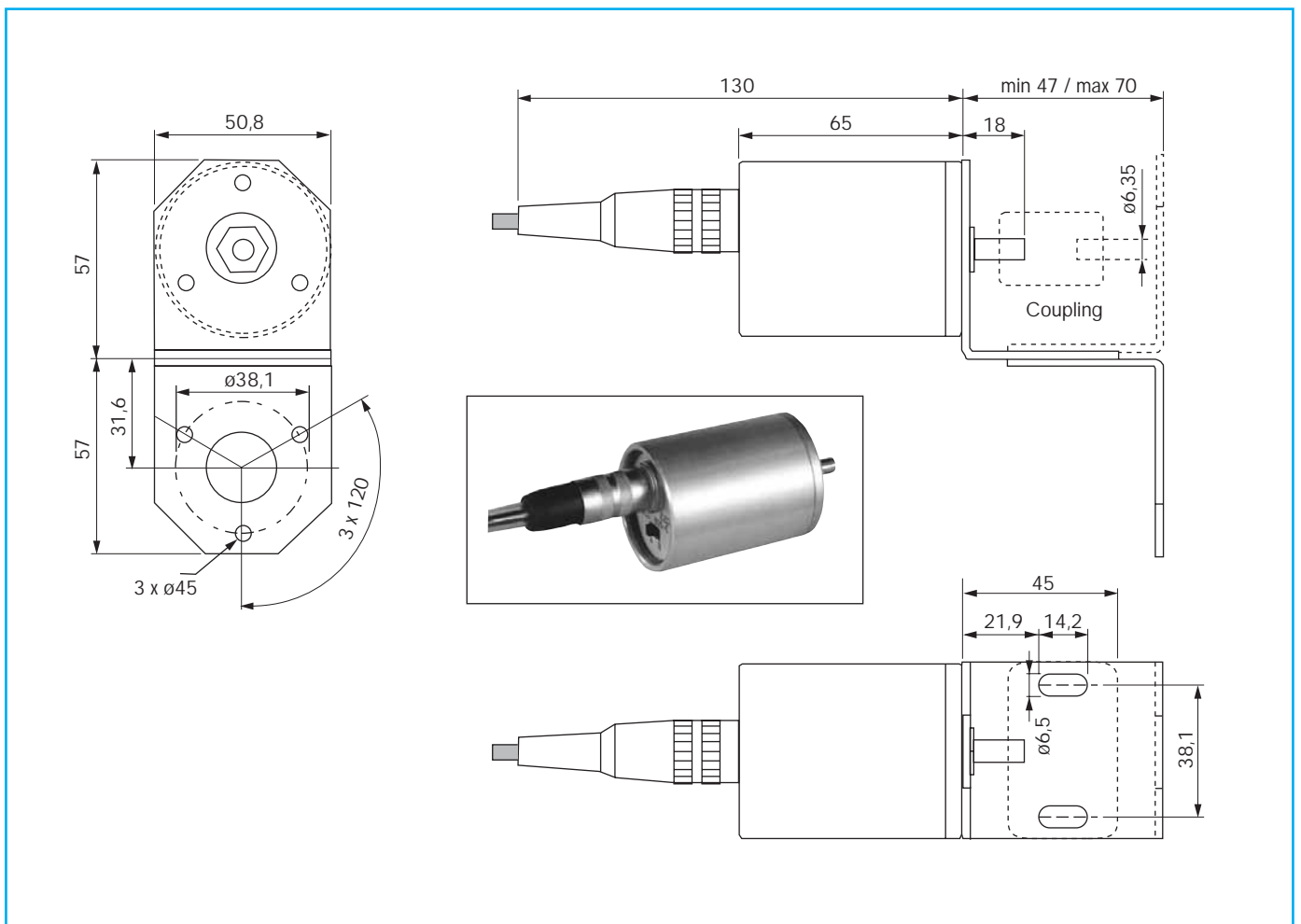

Automatic setting by dancer arm

HMCS605-E2 - MOUNTING KIT

The **HMCS202-Exx** is designed to work with dancer arm principle. Usually the sensor is a rotary type.

Warner Electric sensor **HMCS605-E2** are delivered without mounting kit.

Mounting kit comprises of **CABLE WITH CONNECTOR(S), COUPLING, MOUNTING BRACKETS** and all necessary **SCREWS**. Various KITS have various lengths of cable and cable with or without connector at control end side.

HMCS2000 line requires free leads (HMCS2000 control line is provided with terminal block).

HMCS202-Exx requires a connector (HMCS202-Exx is provided with the connector).

Old kit 3 wires	New kit 4 wires	Cable length	1 or 2 connectors	Compatibility	Wiring
HMCS-KIT1	HMCS-KIT1A	3 m	2	HMCS202-E1	A
HMCS-KIT2	HMCS-KIT2A	3 m	1	HMCS2000-ECA/CTDA	B
HMCS-KIT3	HMCS-KIT3A	4,5 m	2	HMCS202-E1	A
HMCS-KIT4	HMCS-KIT4A	4,5 m	1	HMCS2000-ECA/CTDA	B
HMCS-KIT7	HMCS-KIT7A	6 m	2	HMCS202-E1	A
HMCS-KIT8	HMCS-KIT8A	8 m	1	HMCS2000-ECA/CTDA	B

ELECTRICAL CONNECTIONS

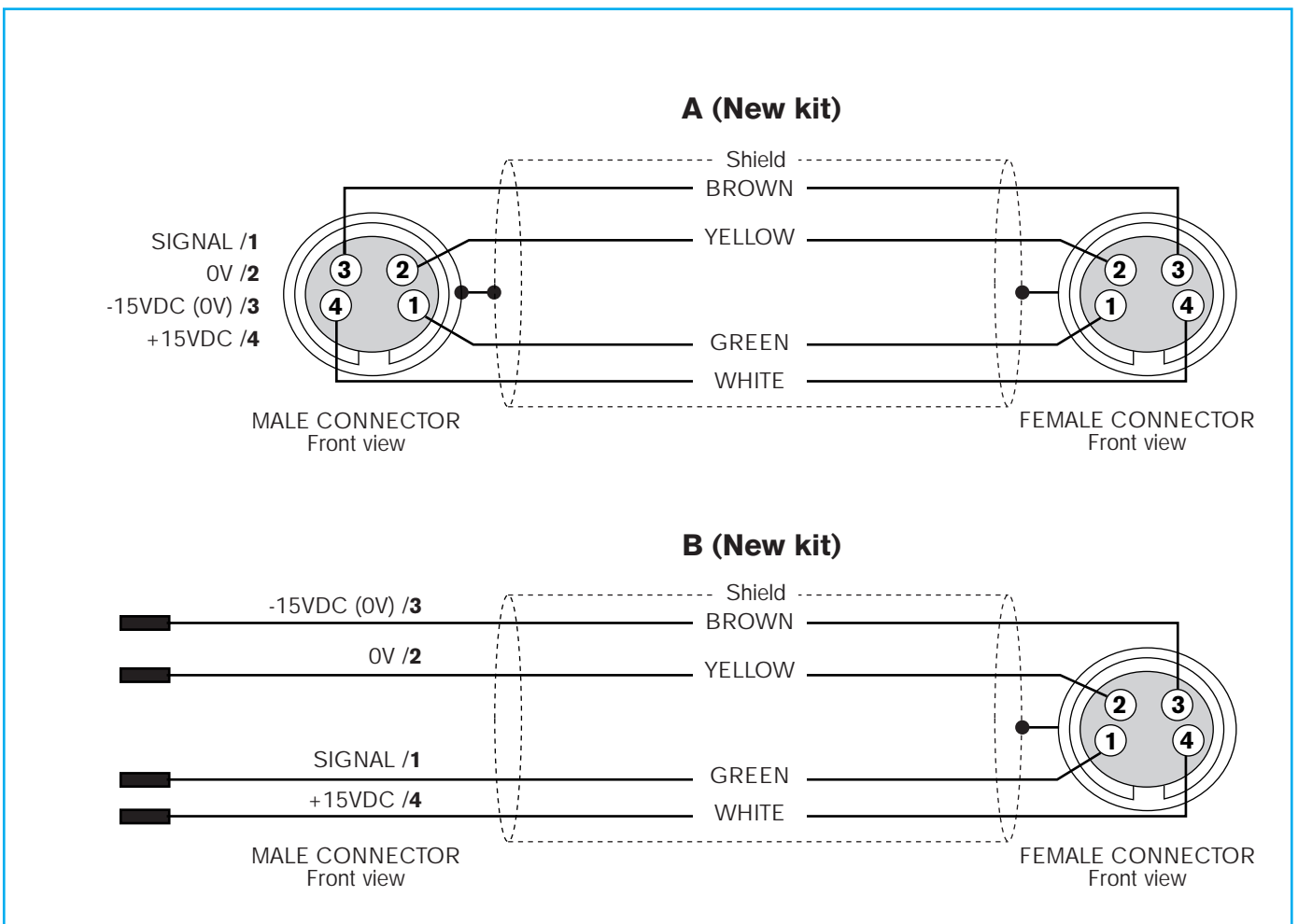

II - Double tension control in closed loop (modular)

HMCS2000-ECA is a digital controller that can be used in both open or closed loop. Operation in open and closed loop is also possible. It is mainly destined for OEM application. The programming tool is detachable. Sensor, sensor mounting kit, display are available as options. The unit has to be powered with 24 VDC.

MAIN APPLICATIONS - ADVANTAGE

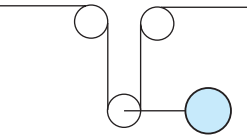
Setting type	Where, When, Why ?	Advantage
Dancer arm 	<input type="checkbox"/> Printing machines <input type="checkbox"/> Intermittent function <input type="checkbox"/> Flying splice need	<input type="checkbox"/> Absorb tension peak <input type="checkbox"/> Can act as store <input type="checkbox"/> Easy flying splice <input type="checkbox"/> Accel / decel machine phase well absorbed <input type="checkbox"/> Flexibility

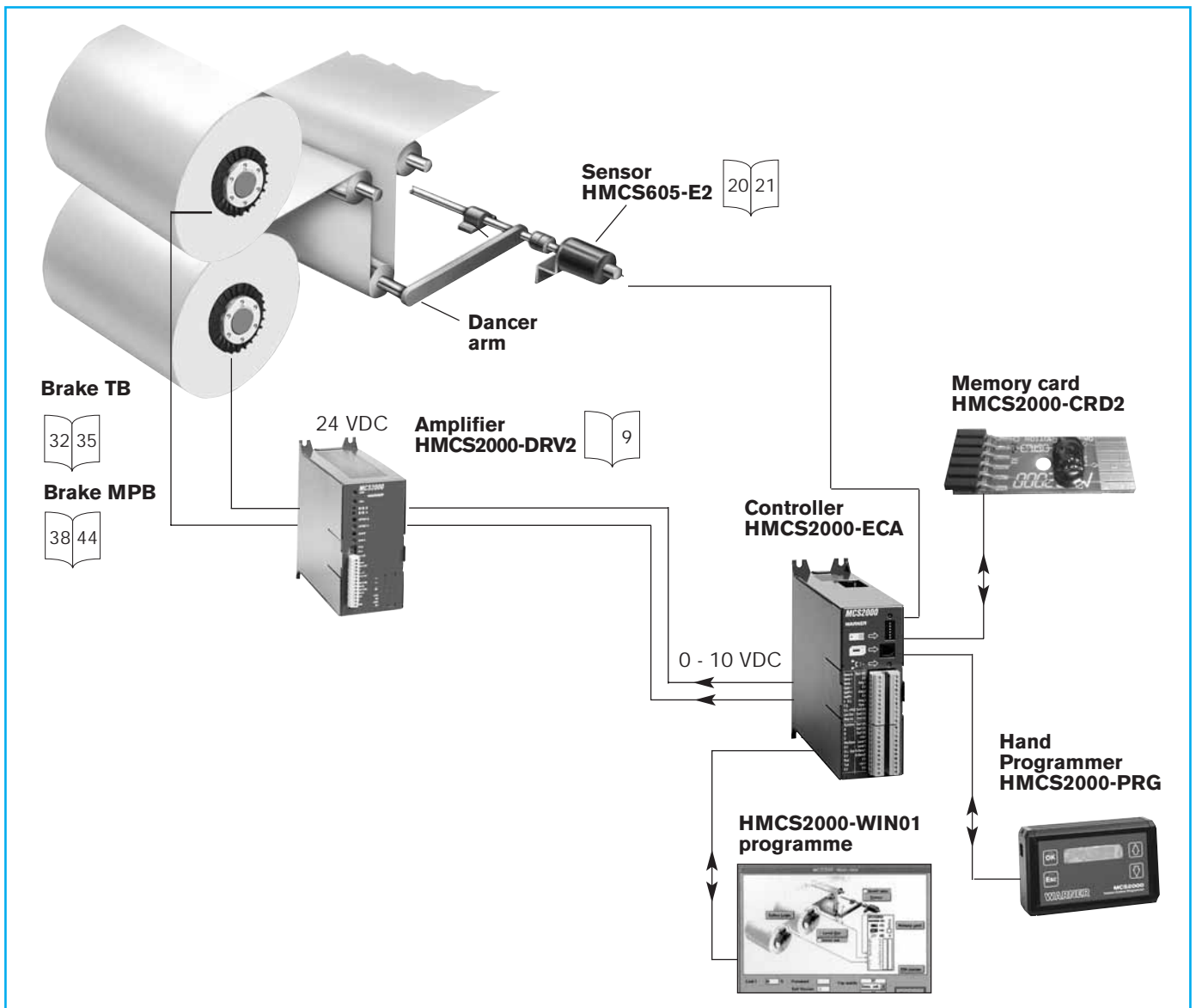

Automatic setting by dancer arm

POWER SUPPLY BTCS252/255 and HMCS2000-DRV2 (see page 9)

ROTARY SENSOR HMCS605-E2 (see pages 20 and 21)

CONTROLLER HMCS2000-ECA

- ❑ Digital controller - 2 channels

Main Characteristics

- ❑ 24 VDC power supply unit
- ❑ PID parameters setting on line
- ❑ Automatic adaptation for PID parameters, splicing logic included
- ❑ Opto isolation for input and output
- ❑ Compatible PLC
- ❑ Automatic sensor scaling and output sensor information
- ❑ Programming easy by pocket keyboard or PC(Windows)
- ❑ Available in open loop as calculator
- ❑ 2 analogic input, 2 output channels
- ❑ Plugable memory card
- ❑ Three language available
- ❑ Most dedicated for unwinding and rewinding with electromagnetic brakes and clutches.
- ❑ Service manual : MC514



BTCS232FM - RS232 SERIAL CABLE

The **BTCS232FM** cable is specially adapted to connect MCS2000 range controls to PC.

- ❑ Service manual : SM374



HMCS2000-PRG - HAND PROGRAMMER

- ❑ 4 command keys only
- ❑ 2 x 16 characters display
- ❑ Menu in 3 languages
- ❑ Connectable and disconnectable during operation
- ❑ Supply by control HMCS 2000-EC



HMCS2000-CRD2 - MEMORY CARD

All setting data saved. It allows a quick loading operation on new machine or on running machine to optimise.

- ❑ Memory for 2 different programs
- ❑ Plugable on line in HMCS2000-ECA unit



HMCS2000-WIN01 - PROGRAMME

The program can modify the running setting by this software running with: Windows 95/98/XP/2000.

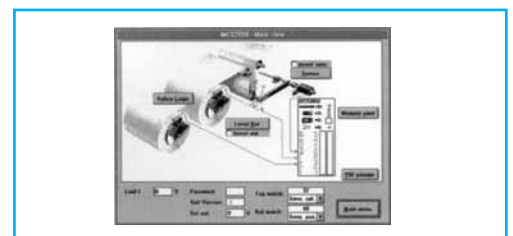

III - Double tension control in closed loop (compact)

The command unit **HMCS2000-CTDA** is a complete solution with power supply and programmer display integrated. There are 2 software version available. See technical data below

MAIN APPLICATIONS - ADVANTAGE

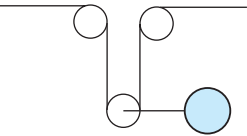
Setting type	Where, When, Why ?	Advantage
Dancer arm 	<input type="checkbox"/> Printing machines <input type="checkbox"/> Intermittent function <input type="checkbox"/> Flying splice need	<input type="checkbox"/> Absorb tension peak <input type="checkbox"/> Can act as store <input type="checkbox"/> Easy flying splice <input type="checkbox"/> Accel / decel machine phase well absorbed <input type="checkbox"/> Flexibility

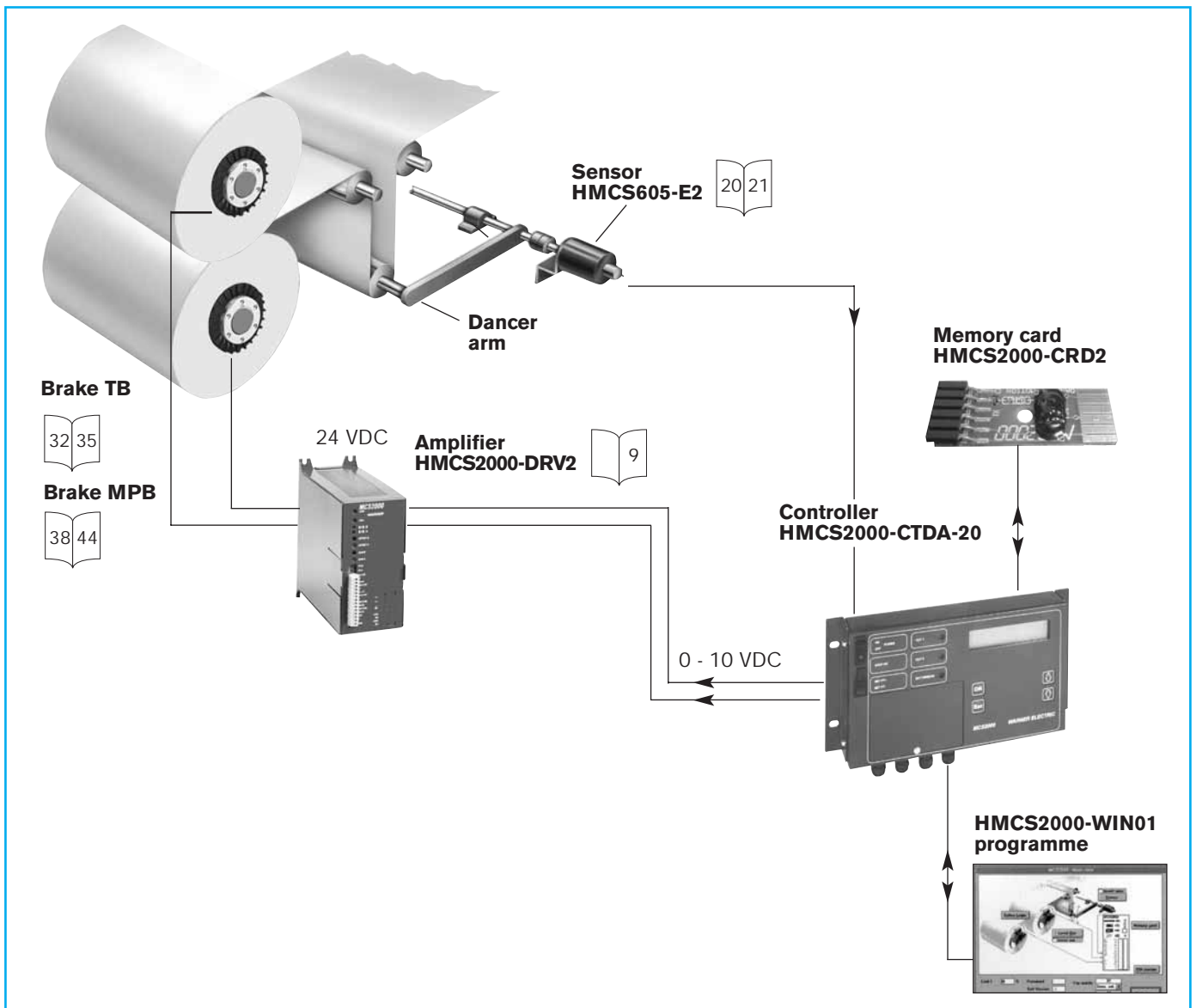

Automatic setting by dancer arm

POWER SUPPLY BTCS252/255 and HMCS2000-DRV2 (see page 9)

ROTARY SENSOR HMCS605-E2 (see pages 20 and 21)

BTCS232FM - RS232 SERIAL CABLE (see page 23)

CONTROLLER HMCS2000-CTDA20



Specifications

Input power supply	110-240 VAC selectable
Analogue inputs Two analogue inputs	0-10 VDC
Analogue outputs Two controlled channels Open loop signal	± 10 VDC, 0-20 mA 0-10 VDC
Digital inputs Set point change + Set point change - Set point change ±	active low active low front face switch
Gain multiplier	active low
Output limitation	active low
ABC binary combination	active low
ABC inputs synchronisation	active low
Stop integral form	active low
Digital outputs Sensor level indication	Two binary outputs
Other outputs Power supply sensor	± 15 VDC / 100 mA ± 5 VDC / 100 mA
Power supply	24 VDC
Voltage reference	+ 10 VDC / 10 mA

Main features

- Three mounting possibilities
- Software password protected
- Scrolling menu program
- Multipurpose application
- RS232 communication
- Two output channels
- Automatic sensor scaling
- Programmable output configuration
- Output sensor information
- External set point change
- Automatic or imposed PID correction
- All features requested for tension control
- Pluggable memory card
- Variable tension value to prevent telescopic effect on unwinding – CTDA-22
- Service manual : MC525

HMCS2000-CRD2 - MEMORY CARD

All setting data saved. It allows a quick loading operation on new machine or on running machine to optimise.

- Memory for 2 different programs
- Pluggable on line in HMCS2000-ECA unit



HMCS2000-WIN01 - PROGRAMME

The program can modify the running setting by this software running with: Windows 95/98/XP/2000.

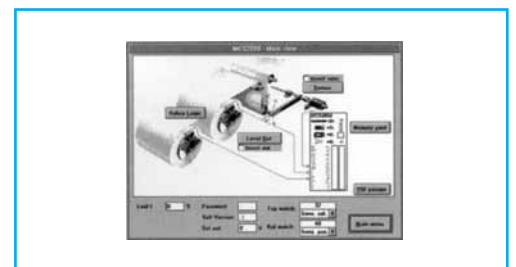

IV - Double tension control in closed loop

The command unit **HMCS2000-CTLC** is a complete solution with power supply and programmer display integrated. There are 2 software version available. See technical data below

MAIN APPLICATIONS - ADVANTAGE

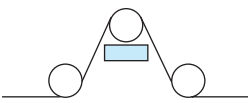
Setting type	Where, When, Why ?	Advantage
Load cell 	<input type="checkbox"/> Slitter, Sheeter and Coater <input type="checkbox"/> For heavy material <input type="checkbox"/> Limited room <input type="checkbox"/> No fast accel/decel <input type="checkbox"/> Tension peak accepted	<input type="checkbox"/> Direct tension measure <input type="checkbox"/> Mechanically well integrated <input type="checkbox"/> No moving part

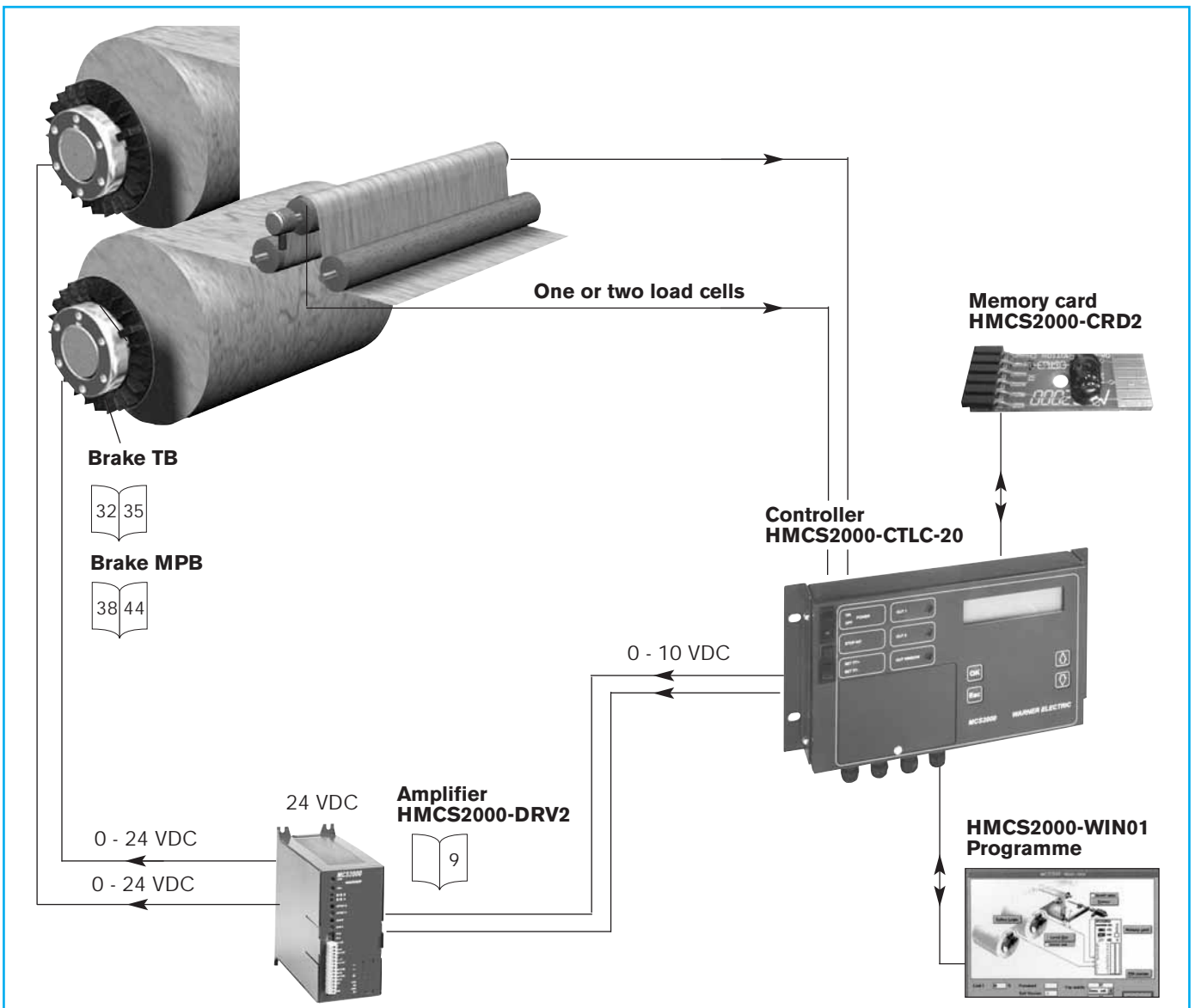

Automatic setting by load cell

POWER SUPPLY BTCS252/255 and HMCS2000-DRV2 (see page 9)

BTCS232FM - RS232 SERIAL CABLE (see page 23)

CONTROLLER HMCS-2000-CTLC-20



Specifications

Input power supply	110-240 VAC selectable
Analogue inputs Two analogue inputs	0-10 VDC
Analogue outputs Two controlled channels Open loop signal	± 10 VDC, 0-20 mA 0-10 VDC
Digital inputs Set point change + Set point change - Set point change ±	active low active low front face switch
Gain multiplier	active low
Output limitation	active low
ABC binary combination	active low
ABC inputs synchronisation	active low
Stop integral form	active low
Digital outputs Sensor level indication	Two binary outputs
Other outputs Power supply sensor	± 15 VDC / 100 mA ± 5 VDC / 100 mA
Power supply	24 VDC
Voltage reference	+ 10 VDC / 10 mA

Main features

- Three mounting possibilities
- Software password protected
- Scrolling menu program
- Multipurpose application
- RS232 communication
- Two output channels
- Automatic sensor scaling
- Programmable output configuration
- Output sensor information
- External set point change
- Automatic or imposed PID correction
- All features requested for tension control
- Pluggable memory card
- Variable tension value to prevent telescopic effect on unwinding – CTLC-22
- Service manual : MC516

HMCS2000-CRD2 - MEMORY CARD

All setting data saved. It allows a quick loading operation on new machine or on running machine to optimise.

- Memory for 2 different programs
- Pluggable on line in HMCS2000-ECA unit

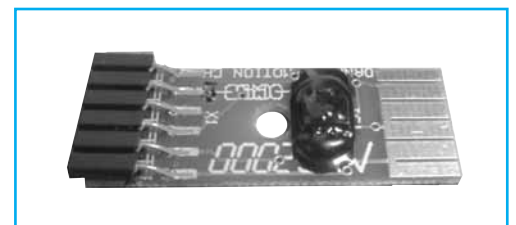

HMCS2000-WIN01 - PROGRAMME

The program can modify the running setting by this software running with: Windows 95/98/XP/2000.

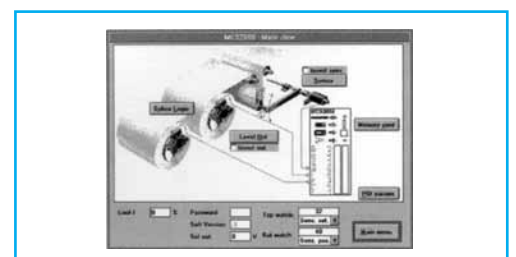

Load cells

The **FOOT MOUNTED LOAD CELL** is the ideal solution to retrofit machines or for heavy tension measurement. The foot mounted model has to be installed with a pillow block type ball bearing supporting the sensing shaft. **HFM01A...** and **HFM02-...** are only differentiated by the physical dimensions.

FOOT MOUNTED TYPE FM01A... and FM02-...

Foot mounted load cells are available in two versions:

With incorporated amplifier : **HFM.....-AC**
AC = amplifier and connector on the load cell body

Without amplifier : **HFM.....-C**
C = connector on load cell body

Specifications (all HFM series)

	HFM.....-AC	HFM.....-C
Power supply	±12 to ±15 VDC	± 5 VCC or +10 VDC
Sensitivity	0-5 VDC, nominal load	10 mV, nominal load
Rating	100 – 250 – 500 – 1000 – 2500 – 5000 – 10000 N	
Connections	Cable supplied	
Permitted overload		
- Compression	150 %	
- Extension	120 %	
Radial permitted force	50%	
Dimensions	See mounting instructions ref. MC480	
Mounting	See recommendations on page 29	
Service manual	MC480	



AVAILABLE MODELS / CAPACITY

Nom. load	100 N	250 N	500 N	1000 N	2500 N	5000 N	10000 N
HFM01A-	-100-AC	-250-AC	-500-AC	-1000-AC	-2500-AC	-5000-AC	
HFM01A-	-100-C	-250-C	-500-C	-1000-C	-2500-C	-5000-C	
HFM02..-						-5000-AC	-10000-AC
HFM02..-						-5000-C	-10000-C

HMCS2000-IS - Load Cell Interface

The interface sensor will sum and amplify the input signals from two load cells, and can be used with a number of different load cells. The interface should be positioned close to the load cells to ensure that no noise is injected into the low voltage signal before it is amplified.



Specifications

Input power / Output power

Input supply: +24 VDC, ±10%, 300 mA

Analog inputs

2 load cell input: any voltage between 20 mV and 10 VDC 5 K Ω input impedance

Ultrasonic input: 0-10 VDC, delta mon. of 1 V
 10 K Ω input impedance
 max. gain: 1000

3 inputs for line speed: 0-10 VDC, 10 K Ω impedance

Analog outputs (short circuit protected)

Calibrated load cell/
 ultrasonic-sensor output: 0-10 VDC, 10 mA max.

Power for ultrasonic sensor: +24 VDC

Voltage reference: 10 VDC, 10 mA

Service manual: MC521

Load cells

END SHAFT LOAD CELLS are normally used in new machines designed with the possibility to place the load cell directly on the sensing roll. The end shaft version offers the advantage of being able to easily place the load cell in any tension resultant direction. The **HES** model exists in two versions differentiated with the diameter of ball bearing which has to be placed in.

All end shaft load cells are based on the Wheatstone bridge principle. They have no built in amplifier. They are delivering a signal which is proportionnal to the voltage supply and tension applied. It is important to respect the measurement direction referenced on the load cell body (normally an arrow indicates the sensitive direction).

HES... LOAD CELL FEATURES

	HES01-40C and HES02-52C
Power supply	10 to 15 VDC / 40 mA (± 5 VDC in Warner Electric control)
Sensitivity	2 mV / V supply at nominal load 1 mV / V supply for 50 and 150 N models
Rating	50-150-250-500-1000-2000 N
Connections	5 m shielded cable supplied
Mechanical overload	Max 150 % in any direction
Dimensions	See mounting instructions ref. MC481 and MC482
Mounting	See recommendations below
Service manual	MC481 and MC482



AVAILABLE MODELS / CAPACITY

Nominal load	150 N	250 N	500 N	1000 N	2000 N
HES01-...	-150-40C	-250-40C	-500-40C	-1000-40C	-2000-40C
HES02-...	-	-250-52C	-500-52C	-1000-52C	-2000-52C

LOAD CELLS SIZING - MOUNTING RECOMMENDATIONS

Please keep this principle in mind: **the load cell installed is destined to measure the WEB TENSION and not other constraints applied to it.**

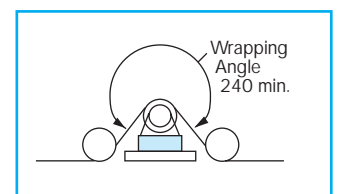

Take the following points into consideration before selecting, sizing and installing material components.

- Load cells location should be vibration free. Vibrations will decrease quality measurement.
- The sensing shaft fitted on or in has to be very well balanced. Unbalanced shaft will create measurement oscillation, causing variations in control quality.
- Adapted ball bearing have to be used to avoid original stress on load cell (self-aligning ball bearing).
- Respect a reasonable sensing shaft weight/web tension measure ratio. **Less than 1.**
- Do not oversize the load cell respect to your calculation. **Max admitted factor 3, recommended 1,5.**
- Respect a minimum wrapping angle on load cell. **Min = 180°.**
- So far as it is possible, use load cell in compression, with web tension effect in same direction as the weight of shaft.

Tension brakes and clutches range

Brake and clutch types	Series	Main characteristics	Torque range	Pages
Electromagnetic brakes 	TB	Monodisc 24 VDC power supply	0,5 - 300 Nm	
Electromagnetic brakes 	TBM	Monodisc 24 VDC power supply	10 Nm	
Magnetic particle brakes 	MPB BB	Completely packaged and enclosed unit Shaft output or bore 24 or 90 VDC power supply	0,04 - 500 Nm	
Magnetic particle clutches 	MPC BC	Completely packaged and enclosed unit Both end shaft output or bore 24 or 90 VDC power supply	0,04 - 500 Nm	
Permanent magnetic brakes 	MB	Completely packaged and enclosed unit Shaft output Manual setting	0 - 33 Nm	
Permanent magnetic clutches 	MC	Completely packaged and enclosed unit Bore output Manual setting	0,07 Ncm - 33 Nm	

Tension brake sizing

Two important parameters are used in brake selecting:

- ☐ Max. torque requirement
- ☐ Max. thermal power to be dissipated

These two values are determined by the application (see calculation example on pages 78-79).

ELECTROMAGNETIC BRAKE TYPE TB – SELECTION

TB brake selection is based on two values :

Max torque need (Nm) on the brake

*Max brake rotation speed for the max torque (rpm)

* As the curve given for TB selection takes the power dissipation into account, this value is used.

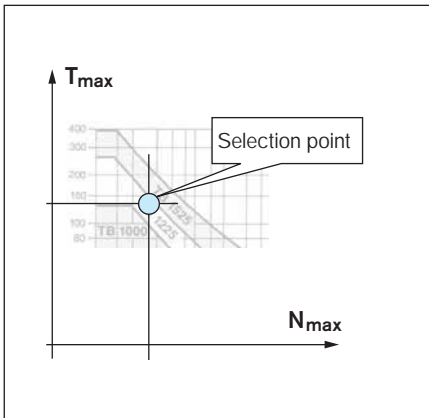

T_{max} = torque needed at the brake for the max tension in material and the max roll diameter - taking any gear ratios into account.

N_{max} = brake rotation speed for the max linear speed and the max roll diameter – taking any gear ratios into account.

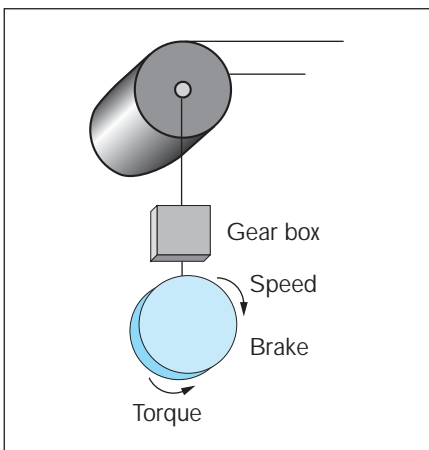

Note : the constant tension in the web gives a constant power on the brake. However, we make the selection for the max torque (then at full roll diameter) because it's the moment where the brake has the least natural cooling.

TB brake selection

The table (pictured below left) illustrates the selection of the correct **TB brake**. The table on the right determines the maximum torque provided by the brake when nominal voltage is applied. After selection you can consult the complete brake characteristics and dimensions on pages 34 to 35.



**Dynamic braking torque
TB170 - TB1525**

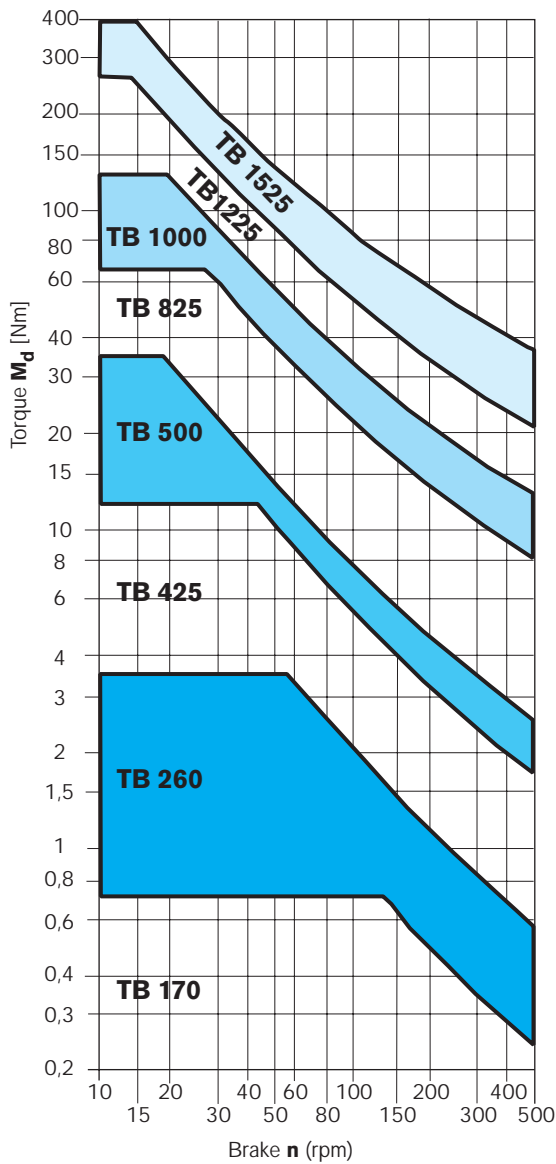

**Maximum braking torque (emergency stop)
TB170 - TB1525**

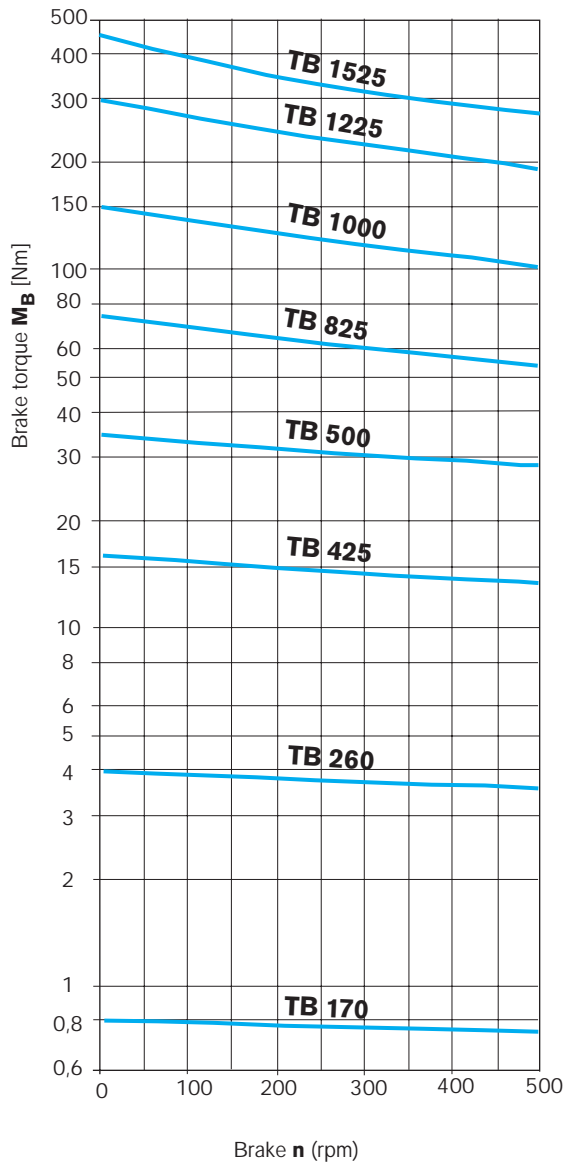

TB brake characteristics

TB units are assembled using various parts described below. Main components of the brake are armature and magnet. Additional parts are offered to provide for ease of mounting.

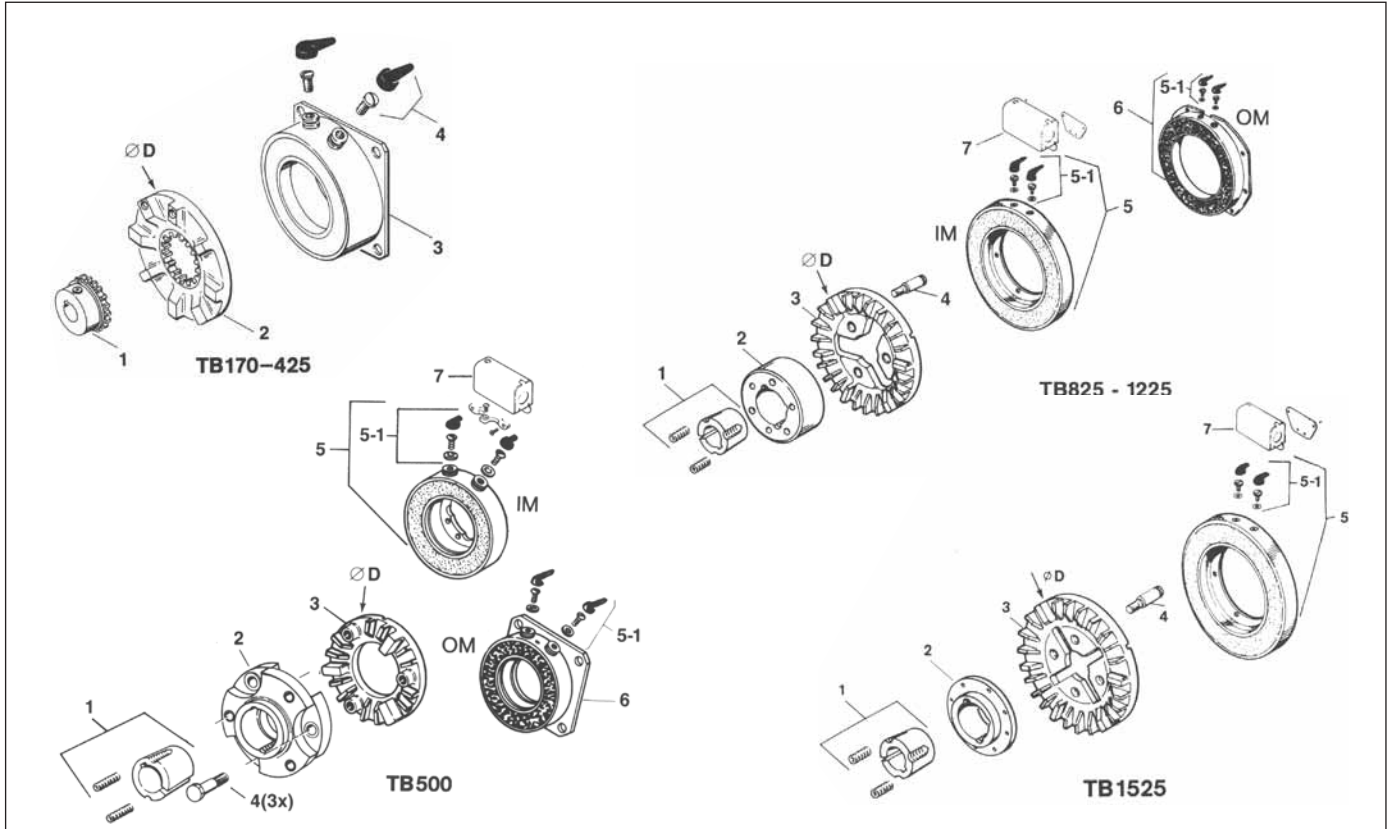

Part	TB170	TB260	TB425
	D = 46 mm	D = 69 mm	D = 111 mm
1 Armature hub*	B5102-541-001-38	B5103-541-001-47	B5104-541-001-31
2 Armature	K110-0096	B110-0097	B110-0098
3 Magnet 24V	K5375-631-012 R = 110 Ω, 20°C	K5365-631-016 R = 60 Ω, 20°C	K5367-631-008 R = 76 Ω, 20°C
4 Terminals	Wires	B5103-101-002	B5103-101-002

* Prebored

** Indicate bore and keyway

Part	TB500
	D = 130 mm
1 Taperlock bushing**	B180-xxxx-xxxx
2 Armature hub	K5300-541-004
3 Armature	B110-0047
4 Drive pins	K5300-101-003 3 x
5 Magnet IM 24V	B5300-631-040
5-1 Terminals	B5311-101-001
6 Magnet OM 24V	B5300-631-000-46
7 Conduit box	K5200-101-010

Part	TB825	TB1000	TB1225	TB1525
	D = 215 mm	D = 259 mm	D = 316 mm	D = 395 mm
1 Taperlock bushing**	B180-xxxx-xxxx	B180-xxxx-xxxx	B180-xxxx-xxxx	B180-xxxx-xxxx
2 Armature hub	B540-0394	B540-0313	B540-0015	B540-0314
3 Armature	B5301-111-019	B5302-111-021	B5303-111-011	B5304-111-005-04
4 Drive pins	B5301-101-001 3 x	B5301-101-001 3 x	B5301-101-001 4 x	B5301-101-001 4 x
4 Magnet IM 24V	B5311-631-000-30 R = 20 Ω, 20°C	B5312-631-000-36 R = 20 Ω, 20°C	B5313-631-000-11 R = 22 Ω, 20°C	B5314-631-000-08 R = 20 Ω, 20°C
5-1 Terminals	B5311-101-001	B5311-101-001	B5311-101-001	B5311-101-001
6 Magnet OM 24V	B5311-631-000-16	-	-	-
7 Conduit box	K5200-101-011	K5200-101-011	K5200-101-011	K5200-101-011

Tension brake for strapping machine

Specially designed for strapping machine, the **electromagnetic brake TBM10** is adjustable for the different kind of plastic film. Mounted on the intermediate roller, it will tighten the plastic film and will permit a perfect strapping.

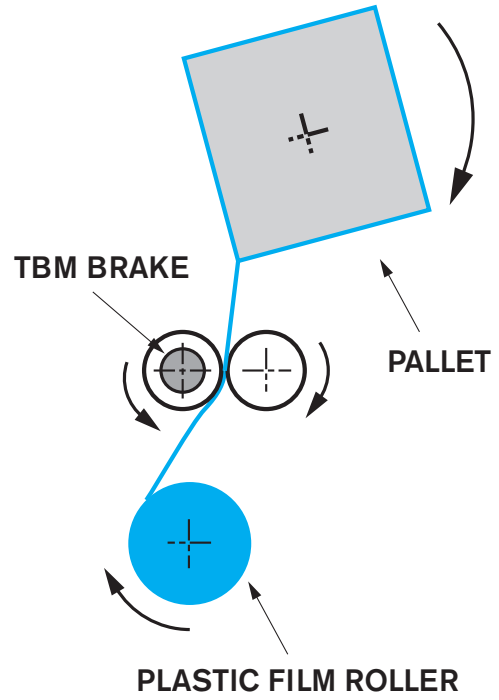

TBM SIZE 10

Heat dissipation torque

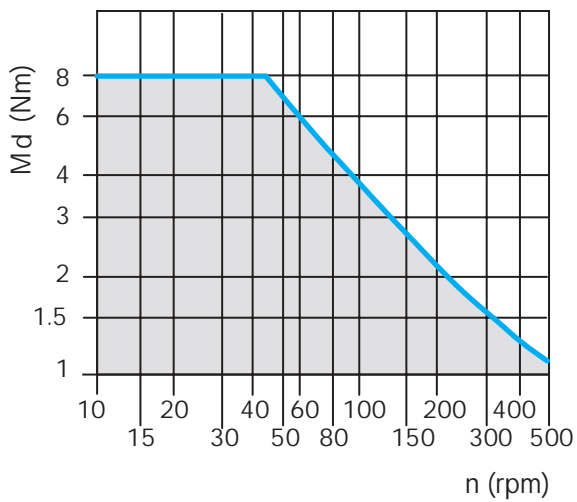

Brake torque

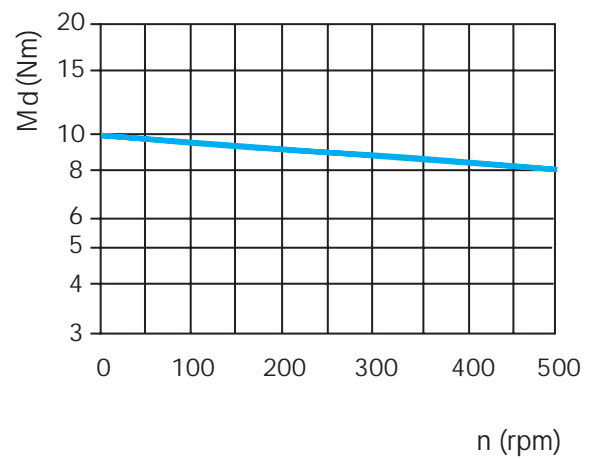

Tension brake for strapping machine

TBM SIZE 10

VAR 03

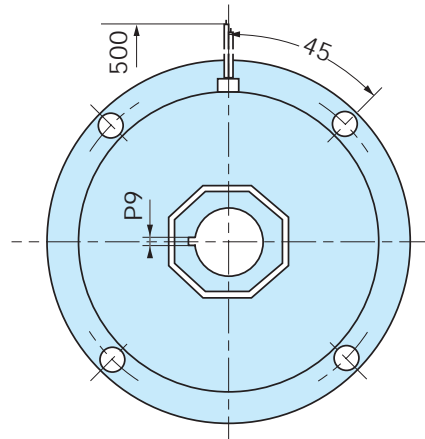
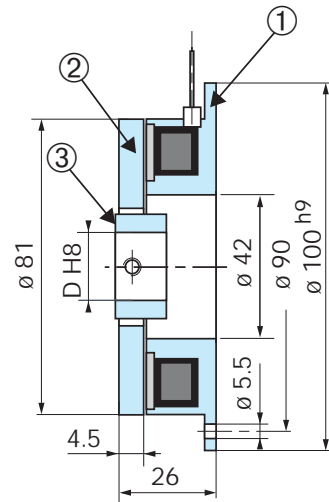

D min = 8 mm with standard keyway
D min = 13 mm with standard keyway

VAR 04

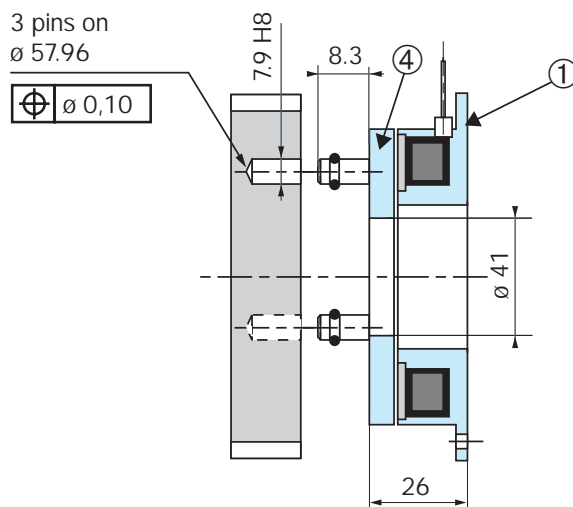

3 pins on
ø 57.96

⊕ ø 0,10

U max : 24 VDC - P 20°C = 10,8 Watts

Keyway according to : ISO R773 / BS 4235 /
NFE 22175 / tolerance P9

	Part	TBM SIZE 10
1	Inductor 24VDC	B6650-631-000-39
2	Armature VAR03	B110-0000-1358
3	Hub prebored ø7,5	B540-0000-2519
	Hub ø12 H8 + Keyway 4 P9	B540-0000-2517
4	Armature VAR04	B6650-111-000-08

Magnetic particle clutches and brakes

Accurate torque control with instantaneous engagement!



Warner Electric Precision Tork™ magnetic particle clutches and brakes are unique because of the wide operating torque range available. Torque to current is almost linear and can be controlled very accurately.

The unique features of the magnetic particle clutches and brakes make them ideal for :

- tension control
- load simulation
- cycling/indexing
- soft starts and stops

Specials are our business

Special Shaft Configurations

- Customer specified shaft configurations for easy machine mounting and retrofitting.

Wash Down Environment

- Stainless steel units available for extreme environments.

Special Torque

- Maximum torque configurations to meet customer specifications.

Features and Benefits

Torque independent of slip speed

- Torque is transmitted through magnetic particle chains which are formed by an electromagnetic field. The torque is independent of slip speed, depending only on circuit current, and is infinitely variable from 0 (disengaged) to rated torque.

Precise engagement

- Precision Tork magnetic particle clutches and brakes engage to transmit torque with speed and precision. Response of the particles to the field is virtually instantaneous, providing perfectly controlled, jerk-free engagement.

Customer specified engagement

- Engagement time may be very gradual or extremely fast. The frequency and torque of the engagement/disengagement sequence is limited only by the capabilities of the control circuitry.

No wearing parts

- There are no friction surfaces to grab or wear, and the units are not affected by changes in atmospheric or other environmental conditions.

Efficient/Compact design

- High torque to size ratio and low consumption of electric power.

Versatile mounting

- Convenient bolt circle for easy mounting.
- Mounting brackets available for all sizes.
- Brakes are available with solid shafts and through bore.
- Can be mounted horizontally or vertically to solve virtually any motion control requirement.

Modular

- Customised products
- Interchangeable with industry standard sizes

Design and operation

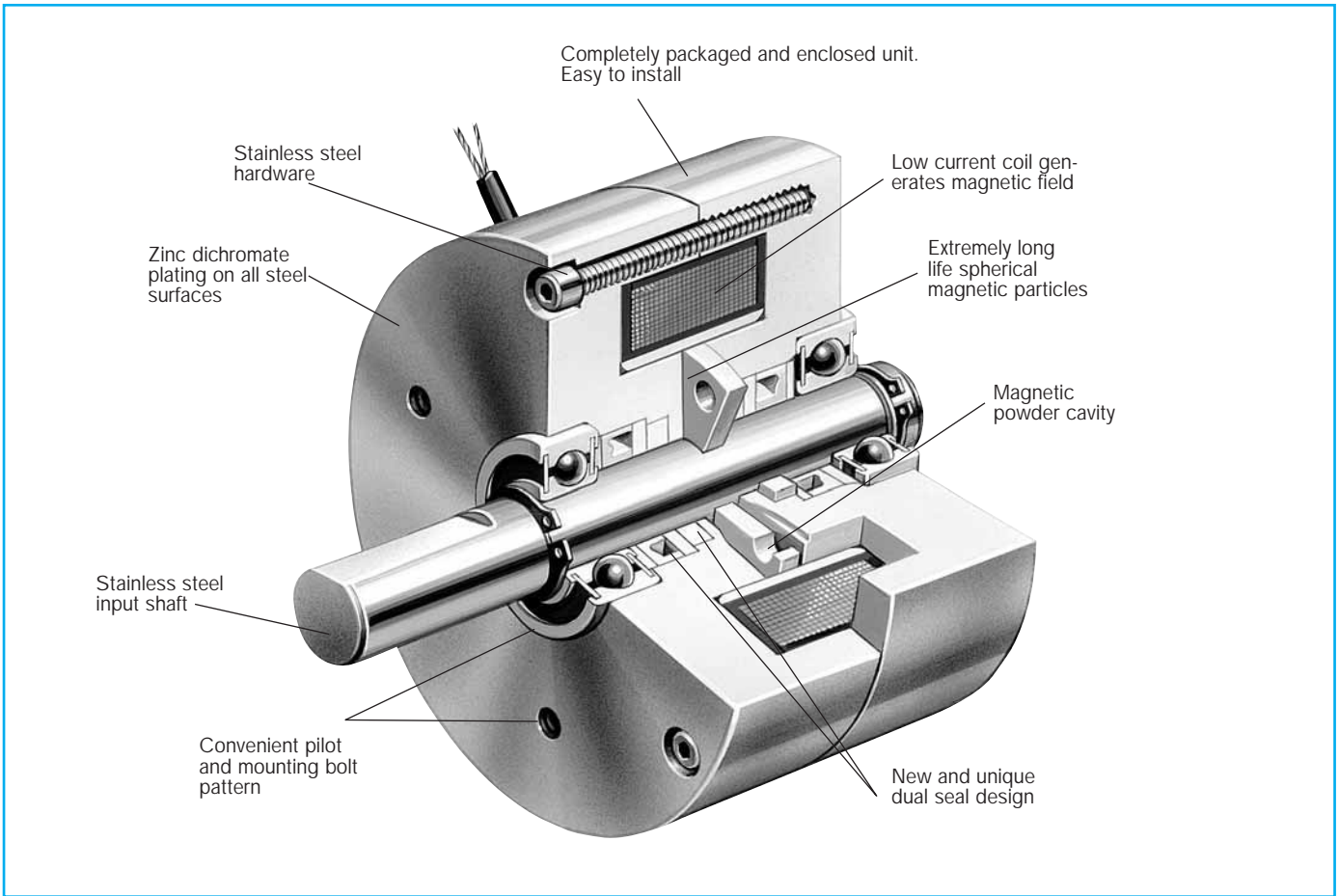

Operating Principles

The magnetic particle unit consists of four main components:

- 1) Housing
- 2) Shaft/disc
- 3) Coil
- 4) Magnetic powder

The coil is assembled inside the housing. The shaft/disc fits inside the housing/coil assembly with an air gap between the two; the air gap is filled with fine magnetic powder.

Engagement

When DC current is applied to the magnetic particle unit, a magnetic flux (chain) is formed, linking the shaft/disc to the housing. As the current is increased the magnetic flux becomes stronger, increasing the torque. The magnetic flux creates extremely smooth torque and virtually no "stick-slip".

Disengagement

When DC current is removed the magnetic powder is free to move within the cavity, allowing the input shaft to rotate freely.

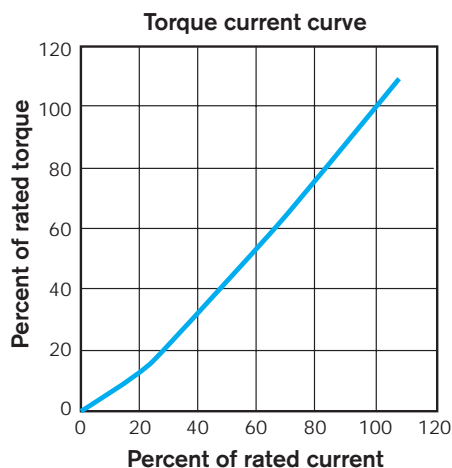
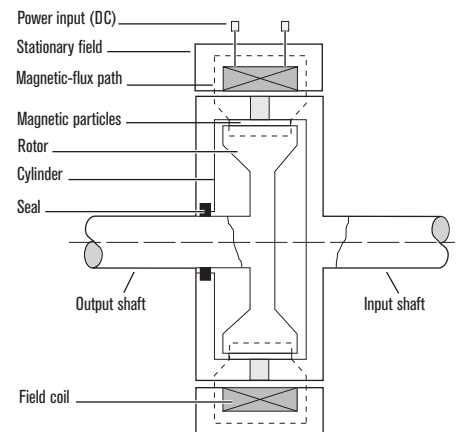

Magnetic particle clutches and brakes

Selection

Sizing

To properly size magnetic particle clutches or brakes the thermal energy (slip watts) and torque transmitted must be considered. If thermal energy and torque are known for the application, select the unit from the charts to the right.

Speed

$$V \text{ (RPM)}^* = \frac{\text{Velocity (m/min)}}{\pi \cdot \varnothing \text{ coil}^{**} \text{ (m)}}$$

* In rewind applications the motor RPM should be higher (10%) than the fastest spool RPM.

** In applications with the web running over a pulley or in a nip roll application use the pulley diameter as the roll diameter.

Thermal Energy (slip watts)

1- When a brake or clutch is slipping, heat is generated. Heat is described in terms of "energy rate" and is a function of speed, inertia, and cycle rate.

For continuous slip applications, such as tension control in an unwind or rewind application slip watts are calculated using the following formula:

$$\text{Slip Watts} = 0,103 \cdot \text{torque (Nm)} \cdot \text{speed (RPM)}$$

2- For cycling applications heat is generated intermittently, and is calculated using the following formula:

$$\text{Slip Watts} = 0,00077 \cdot J \text{ (kgm}^2\text{)} \cdot \frac{\text{speed (RPM)}^2}{10000} \cdot f \frac{\text{cycle}}{\text{min}}$$

The average heat input must be below the clutch or brake's heat dissipation rating. If the application generates intermittent heat dissipation, use the average speed for the thermal energy (slip watts) calculations.

Torque

1- Tension applications calculate torque as a function of roll radius and tension.

$$C \text{ (Nm)} = \frac{T \text{ (N)} \cdot D}{2}$$

2- Soft/controlled stopping applications calculate torque as a function of inertia, speed and desired time to stop the load.

$$C \text{ (Nm)} = \frac{J \text{ (kgm}^2\text{)} \cdot N \text{ (RPM)}}{9,55 \cdot \text{Time (s)}}$$

Magnetic particle clutches and brakes

Quick Selection Charts

MPB2 / MPC2

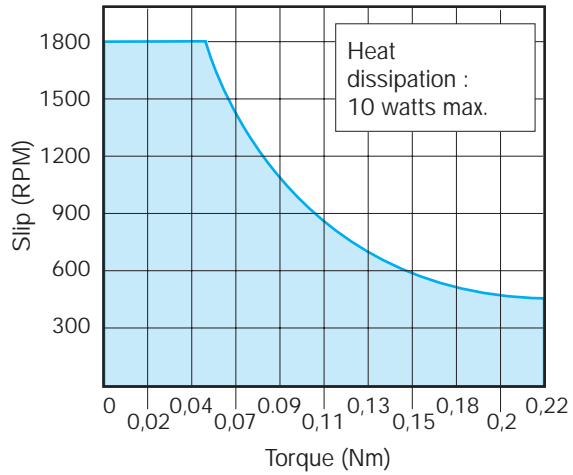

MPB15 / MPC15

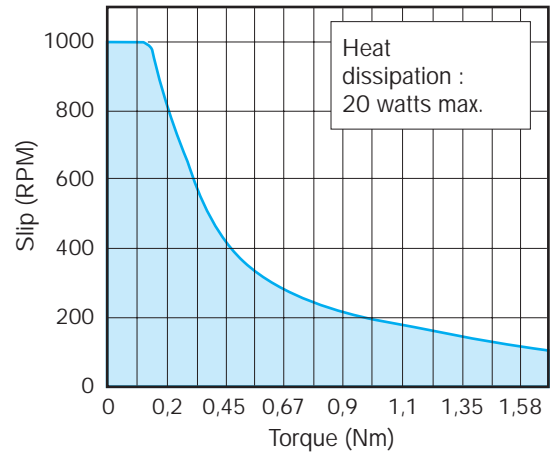

MPB70 / MPC70

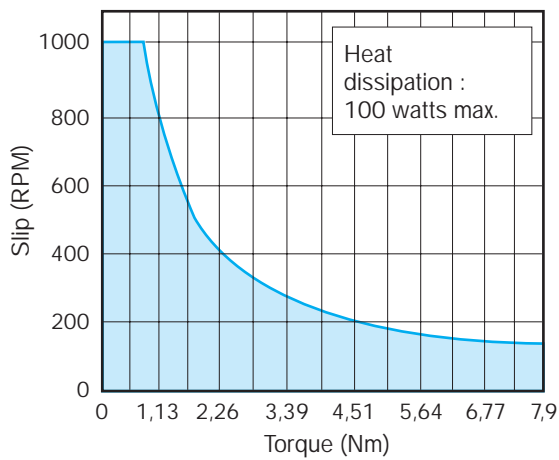

MPB120 / MPC120

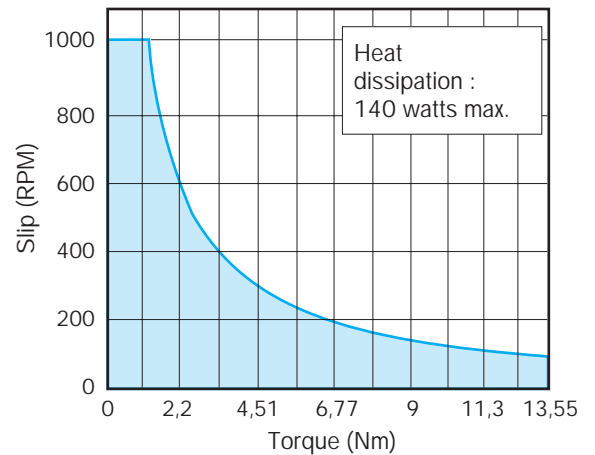

MPB240

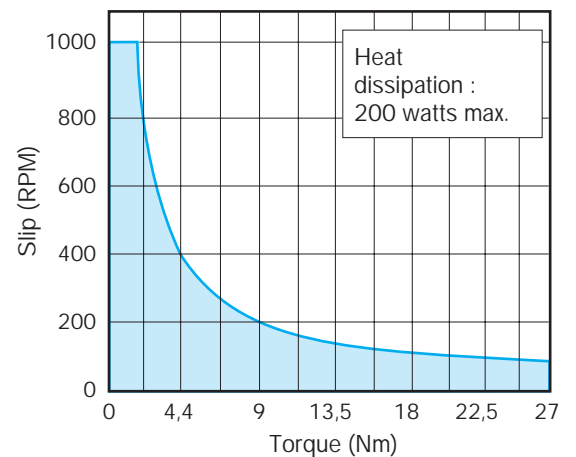

Magnetic particle clutches and brakes

Applications

Warner Electric Precision Tork™ magnetic particle clutches and brakes are the ideal solution for controlling and maintaining torque. If the application is tensioning, load simulation, torque limiting, or soft starts and stops the magnetic particle unit is the preferred torque controlling device.

Typical Applications

- Wire Processing (winding, hooking, cutting)
- Paper/Foil/Film Processing
- Labelling Applications
- Textile Processing
- Load profile simulation on:
 - Exercise Equipment
 - Flight Simulators
 - Healthcare Equipment
- Life testing on:
 - Motors
 - Gears
 - Pulleys
 - Belts
 - Chains
 - Many other Rotating Devices
- Conveyors
- Bottle Capping

Unwind stand under load cell control

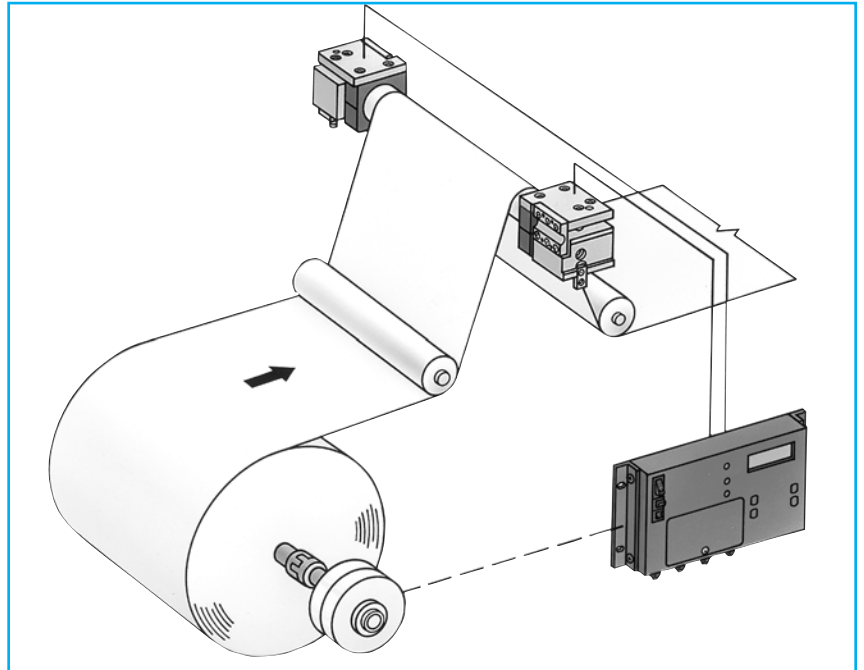

Rewind stand under dancer control

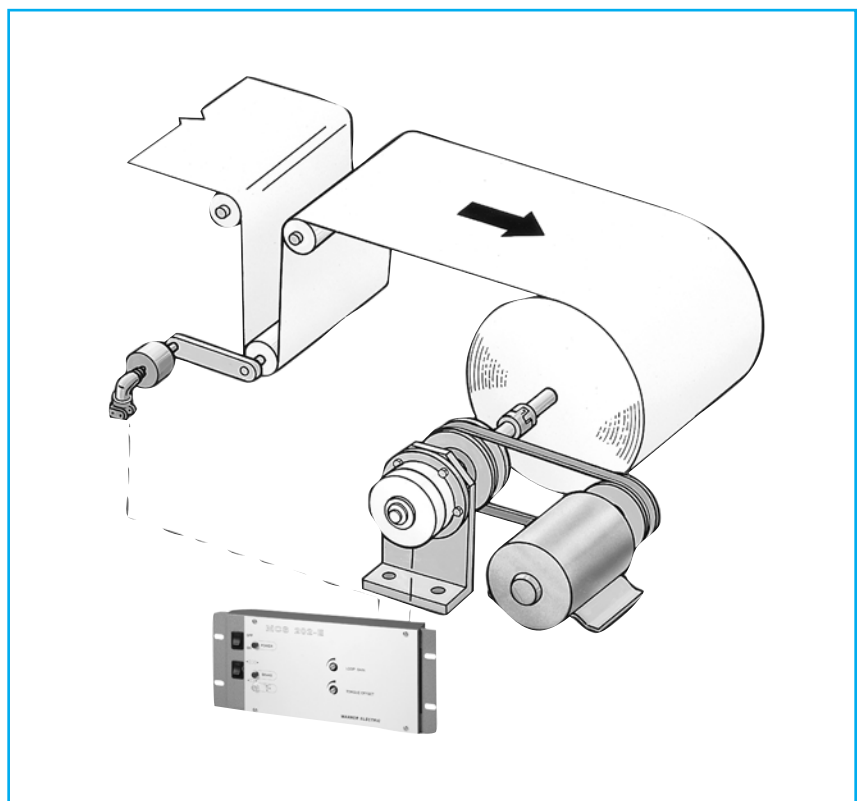

Magnetic particle clutches and brakes

Tensioning

Magnetic Particle clutches and brakes offer smooth controlled torque for tensioning in both the unwind zone and rewind zone. Torque produced from the magnetic particle clutches and brakes is independent of slip speed, offering a distinct advantage over competing technologies. Since torque can be varied infinitely by varying the input current, the magnetic particle clutches and brakes are ideal in an open loop system. To close the loop in the tensioning system, combine the magnetic particle clutch or brake with a Warner Electric sensor and control, resulting in more precise control of tension.

Particle clutches and the MCS2000-CTDA control provide accurate closed loop tension control for rewind applications.

Application example:

Information Full roll \varnothing : 0,5 m
 required: Tension : 22 N
 Velocity : 122 m/min

$$\begin{aligned} \text{Max. torque} &= \frac{\text{tension} \cdot \text{full roll } \varnothing}{2} \\ &= \frac{22 \cdot 0,5}{2} \\ &= 5,5 \text{ Nm} \end{aligned}$$

$$\begin{aligned} \text{Slip} &= \frac{\text{Velocity}}{\pi \cdot D} \\ &= \frac{122}{\pi \cdot 0.5} \\ &= 78 \text{ RPM} \end{aligned}$$

$$\begin{aligned} \text{Heat dissipation} &= 0,103 \cdot \text{torque} \cdot \text{slip} \\ &= 0,103 \cdot 5,5 \cdot 78 \\ &= 44,46 \text{ watts} \end{aligned}$$

Select a brake that exceeds the maximum torque and thermal energy requirements from Quick Selection Chart – **MPB70**.

Particle clutches and the MCS202-E1 control provide accurate closed loop tension control for rewind applications.

Application example:

Information Core \varnothing : 0,08 m
 required: Full roll \varnothing : 0,23 m
 Tension : 22 N
 Velocity : 90 m/mn
 Input speed : 500 RPM*

$$\begin{aligned} \text{Max. torque.} &= \frac{\text{Tension} \cdot \text{full roll } \varnothing}{2} \\ &= \frac{22 \cdot 0.23}{2} \\ &= 2,53 \text{ Nm} \\ &= \frac{\text{Speed}}{(\pi \cdot d)} \\ &= \frac{90}{(\pi \cdot 0,08)} \\ &= 358 \text{ RPM} \end{aligned}$$

$$\begin{aligned} \text{Full roll } \varnothing &= \frac{\text{Speed}}{(\pi \cdot D)} \\ &= \frac{90}{(\pi \cdot 0,23)} \\ &= 125 \text{ RPM} \end{aligned}$$

$$\begin{aligned} \text{Slip} &= \text{Input speed} - \text{Full roll } \varnothing \\ &= 500 - 125 \\ &= 375 \text{ RPM} \end{aligned}$$

$$\begin{aligned} \text{Thermal Energy} &= 0,103 \cdot \text{Torque} \cdot \text{slip} \\ &= 0,103 \cdot 2,53 \cdot 375 \\ &= 97,72 \text{ watts} \end{aligned}$$

Select a clutch that exceeds the maximum torque and thermal energy requirements from the Quick Selection Chart – **MPC120**.

* To maximize tension control and minimize heat generated, select a drive system that will result in an actual input speed as close to, but not less than, 30 RPM greater than the core RPM. In this example, 358 + 30 = 388, would be ideal but 500 RPM was more readily available.

Magnetic particle brakes - MPB

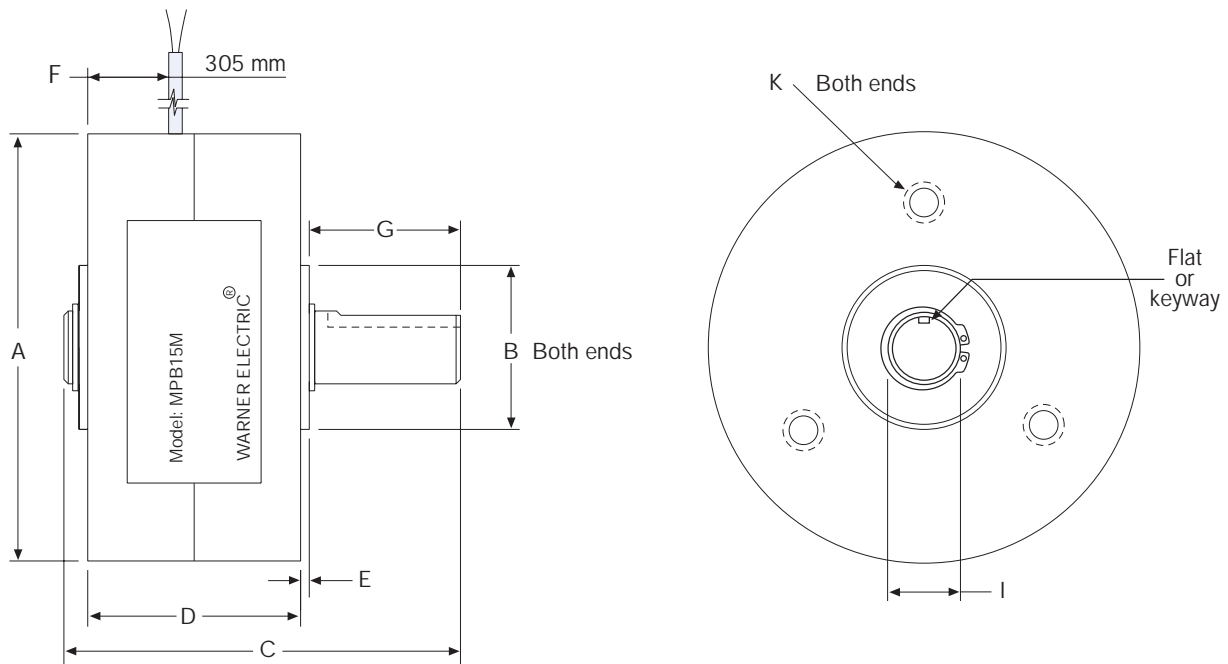

Specifications

Models	Max. torque (Nm)	Drag torque (Nm)	Rated voltage (VDC)	Resistance (Ω)	Rated current (A)	Response zero force (ms)	Response with force (ms)	Inertia of output shaft (kgcm ²)	Max. heat dissipation (W)	Max. speed (RPM)	Weight (kg)
MPB2M-6-24	0,2	0,044	24	92	0,261	8	4	0,0037	10	1800	0,45
MPB15M-12-24	1,7	0,044	24	80	0,302	25	9	0,04	20	1000	1,36
MPB70M-19-24	7,9	0,11	24	35	0,677	70	17	0,23	100	1000	3,2
MPB120M-19-24	13,6	0,22	24	33	0,742	90	25	1,09	140	1000	5,45
MPB240M-24-24	27,1	0,44	24	19	1,286	150	45	3,92	200	1000	9,1
MPB240-007	26,4	0,44	24	19	1,286	150	45	3,92	200	1000	9,1

Dimensions (mm)

Models	Shaft ø I (h7)	Keyway - DIN 6885 (Width x length)	Mounting K	Holes depth
MPB2M-6-24	6	5,5 flat on 16	3 x M4 on ø 34 equidistant	7
MPB15M-12-24	12	4 x 20	3 x M5 on ø 51 equidistant	7,5
MPB70M-19-24	19	6 x 25,4	4 x M5 on ø 107 equidistant	16
MPB120M-19-24	19	6 x 25,4	4 x M6 on ø 122 equidistant	19
MPB240M-24-24	24	8 x 25,4	4 x M6 on ø 149 equidistant	16,5
MPB240-007	29	27 flat on 31,8	4 x M6 on ø 150 equidistant	8

Models	A	Pilot ø B	C	D	E	F	G
MPB2M-6-24	53,59	19,05 - 19,03	56,64	29,21	1,52	18	22,1
MPB15M-12-24	74,39	28,59 - 28,56	77,47	37,08	1,78	21,84	34,29
MPB70M-19-24	116,23	41,29 - 41,26	85,6	44,7	2,54	24,89	31,75
MPB120M-19-24	133,35	41,29 - 41,26	102,11	55,12	2,54	29,97	38,1
MPB240M-24-24	158,57	62,01 - 61,99	118,36	67,31	2,54	37,08	41,91
MPB240-007	158,57	62,01 - 61,99	118,36	67,31	2,54	37,08	41,91

Magnetic particle clutches - MPC

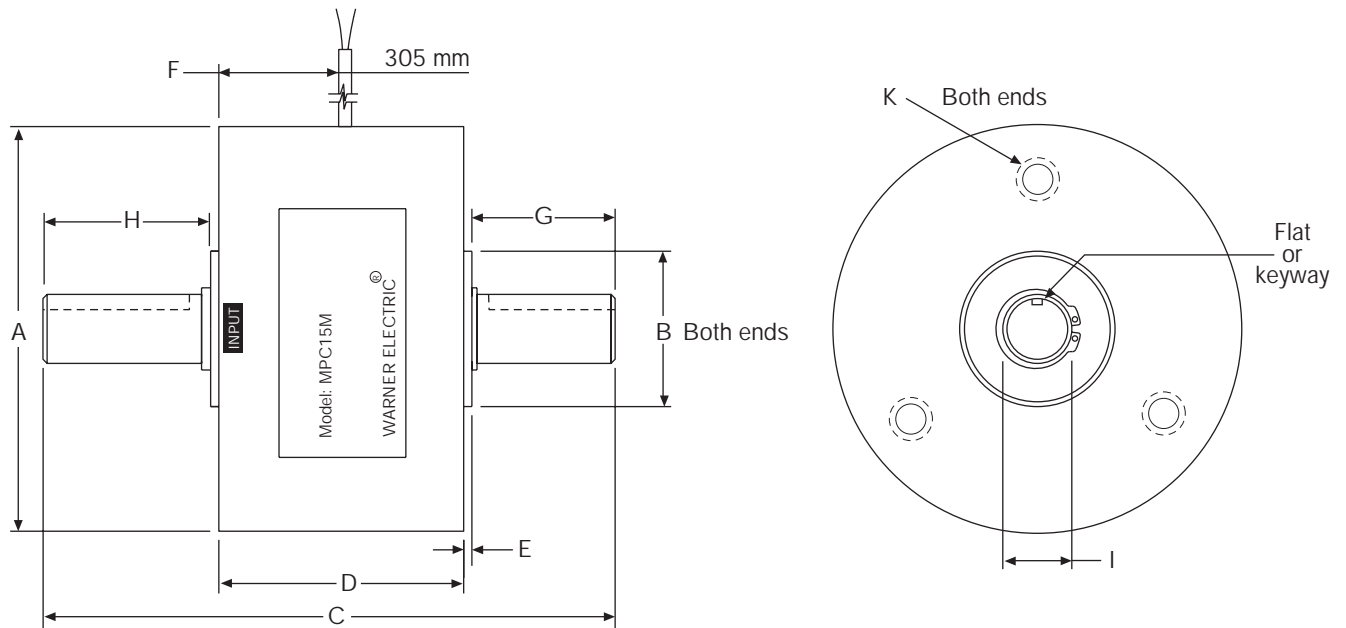

Specifications

Models	Max. torque (Nm)	Drag torque (Nm)	Rated voltage (VDC)	Resistance (Ω)	Rated current (A)	Response zero force (ms)	Response with force (ms)	Inertia of output shaft (kgcm ²)	Max. heat dissipation (W)	Max. speed (RPM)	Weight (kg)
MPC2M-6-24	0,2	0,044	24	92	0,261	8	4	0,0039	10	1800	0,454
MPC15M-12-24	1,7	0,044	24	80	0,302	25	9	0,043	20	1000	2,72
MPC70M-19-24	7,9	0,11	24	35	0,677	70	17	0,26	100	1000	7,71
MPC120M-19-24	13,6	0,22	24	33	0,742	90	25	1,1	140	1000	9,98

Dimensions (mm)

Models	Shaft ø I (h7)	Keyway - DIN 6885 (Width x length)	Mounting K	Holes depth
MPC2M-6-24	6	5,5 flat on 16	3 x M4 on ø 34 equidistant	12,7
MPC15M-12-24	12	4 x 20	3 x M5 on ø 51 equidistant	12,7
MPC70M-19-24	19	6 x 25,4	4 x M5 on ø 107 equidistant	16
MPC120M-19-24	19	6 x 25,4	4 x M6 on ø 122 equidistant	19

Models	A	Pilot ø B	C	D	E	F	G	H
MPC2M-6-24	53,59	19,05 - 19,03	94,74	46,99	1,52	28,46	22,35	22,35
MPC15M-12-24	75,39	28,59 - 28,56	132,3	71,12	1,78	42,93	34,3	23,4
MPC70M-19-24	116,46	41,29 - 41,26	166,37	93,22	2,54	52,83	34,29	34,29
MPC120M-19-24	133,35	62,01 - 61,99	178,31	101,6	2,54	60,96	38,1	34,3

Magnetic particle clutches and brakes

The magnetic particle unit combines the resilience of a fluid coupling with the locked-in stability of a friction clutch. Torque is transmitted by a specially alloyed dry ferromagnetic powder, its apparent viscosity may be changed by modulation of the field coil current.

The units can sustain continuous slip (under maximum heat ratings) at a precise and stable torque value, which is determined by excitation level.

Slip between input and output members is not necessary in order to transmit torque, and provided load torque does not exceed the torque for which a unit is excited to transmit, locked-in synchronous operation will take place.

Conversely, if load torque exceeds the energised torque level, slip will occur in an absolutely smooth manner at the predetermined torque value. For all practical purposes, static and dynamic coefficients of friction are sensibly equal; also, output torque is independent of speed, or slip speed.

Powder performance is unaffected by temperature rise on the working surfaces, and units will, have at all times, a torque directly proportional to current.



It should be noted that use of a dry powder rather than a fluid-suspended powder medium promotes consistency and accuracy of torque control.

Briefly, the unit include two concentric members, the body or input member containing the field coil, and within it, and separated by a small annular gap, an inner rotor, or output member. The annular gap contains a ferromagnetic powder, which is activated when the

coil is energised. The resultant flux which is generated, passed through the powder, causing it to align with the flux path, and thereby creates a driving bond between input and output members, the strength of which is only determined by the value of DC current applied to the coil.

Operating characteristics

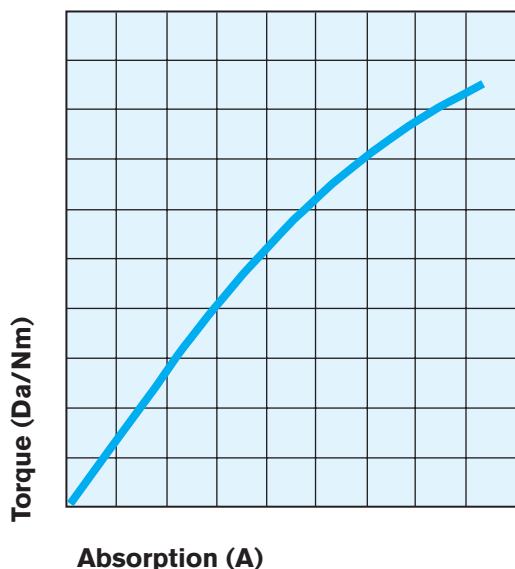

The torque transmitted by powder units is proportional to field current, and is infinitely variable from maximum design rating down to practically zero in all models.

Torque/current characteristic curves can vary by 5 % dependent on whether current is increasing or decreasing. This is due to magnetic hysteresis.

For all practical purposes torque is independent of speed, either with or without the presence of slip, and can be maintained within an accuracy of 5 % for speeds within the recommended operating range 50 to 2600 RPM.

De-energised drag torque due to residual iron circuit magnetism, bearing and seal friction, is less than 1 % of design torque rating for any unit.

Response time to torque is determined by field coil inductance to resistance ratio plus a magnetic delay due to eddy current loss.

Note: to ensure satisfactory operation, all clutches and brakes must be mounted in horizontal axis. For vertical use, please consult us.

Magnetic particle clutches and brakes

BRAKE selection

When min. roll speed and max. torque are known for the application, select the unit from these charts.

For continuous slip applications, as tension control in an unwind or rewind application, slip watts are calculated using the following formula:

$$\text{Slip Watts} = 0,103 \cdot \text{max. torque (Nm)} \cdot \text{min. roll speed (RPM)}$$

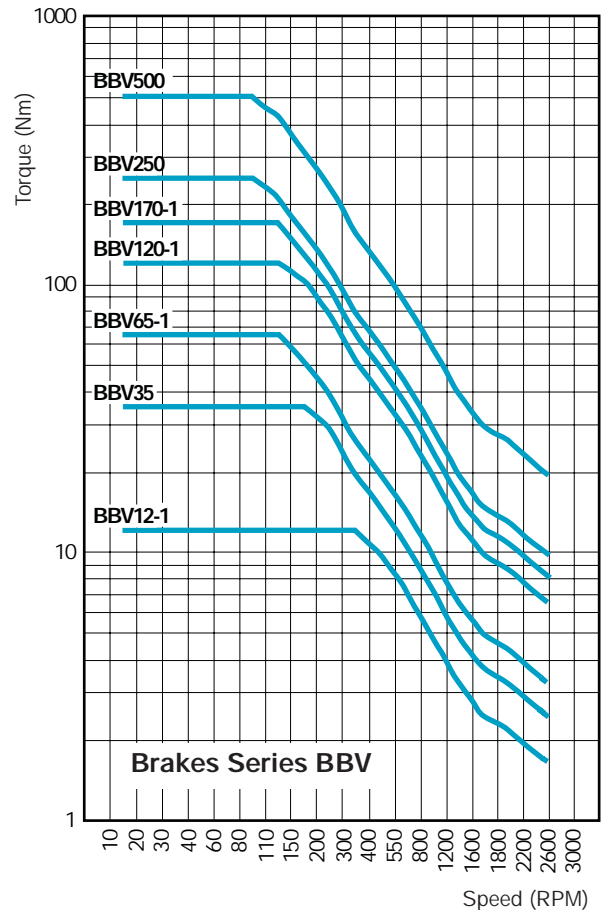
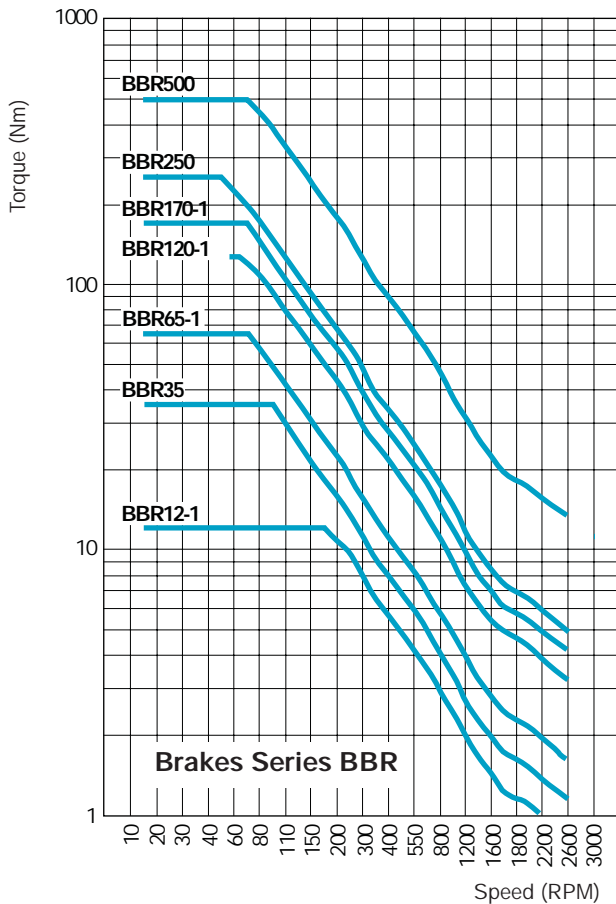
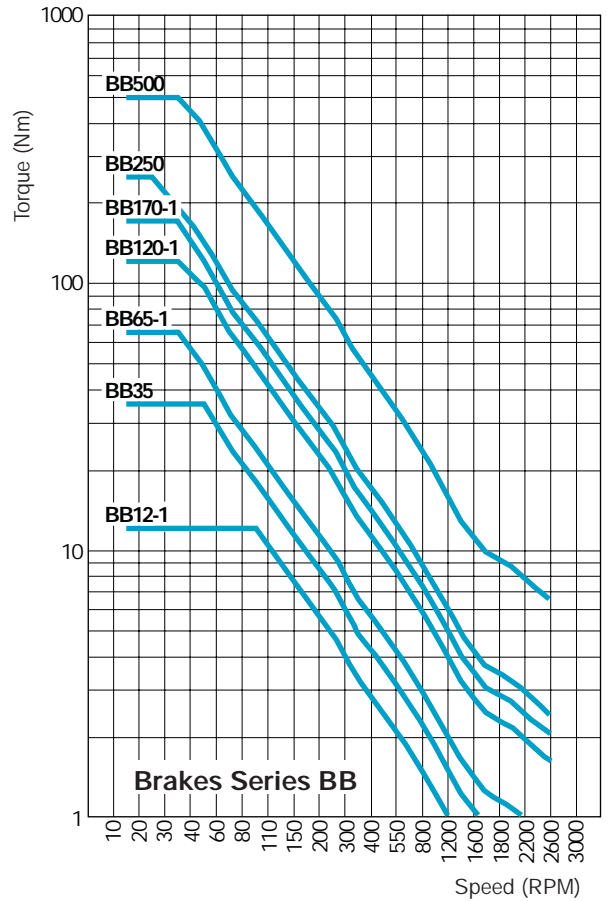

Magnetic particle brakes

BBR2

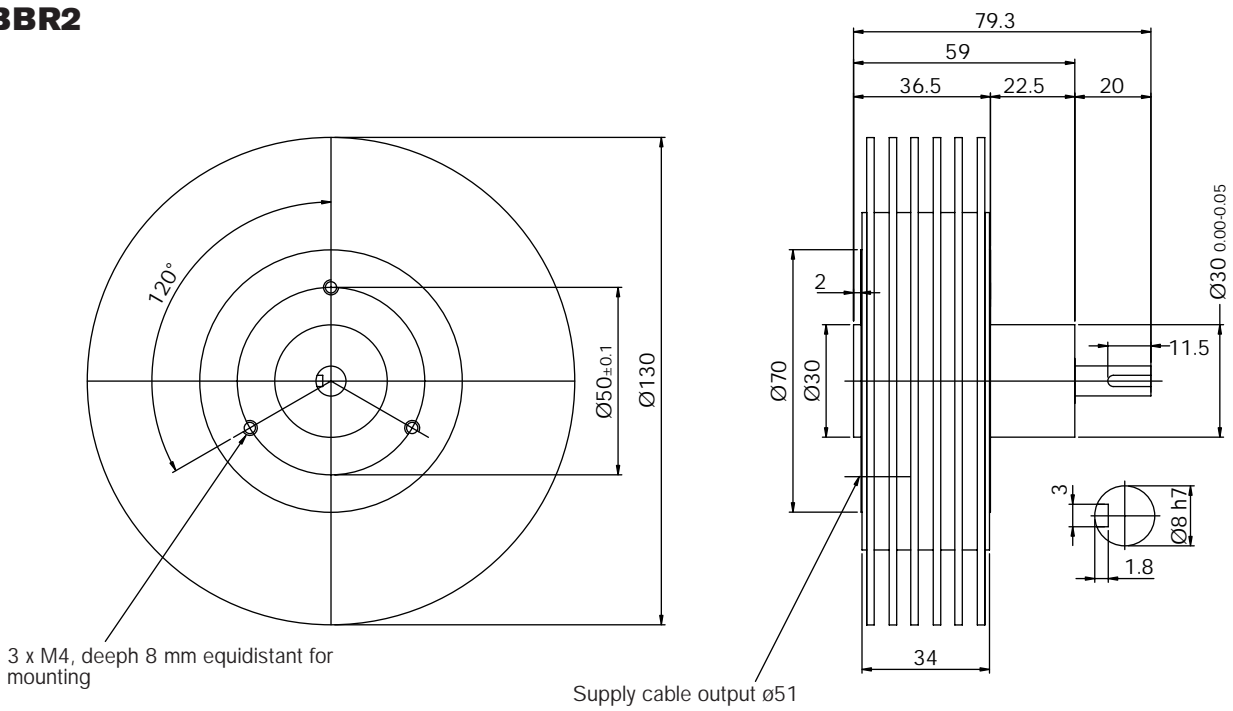

Specifications

Attention : For a correct use of the brake, the operating temperature must not be more than 70° C

Models		BBR2	BB5
Maximum torque	Nm	2	5
Power dissipation	W	55	70
Voltage	V	24	24

Models		BBR2	BB5
Current	A	0,8	1,3
Resistance at 20° C	Ohm	27	16,5
Weight	kg	1,2	1,8

BB5

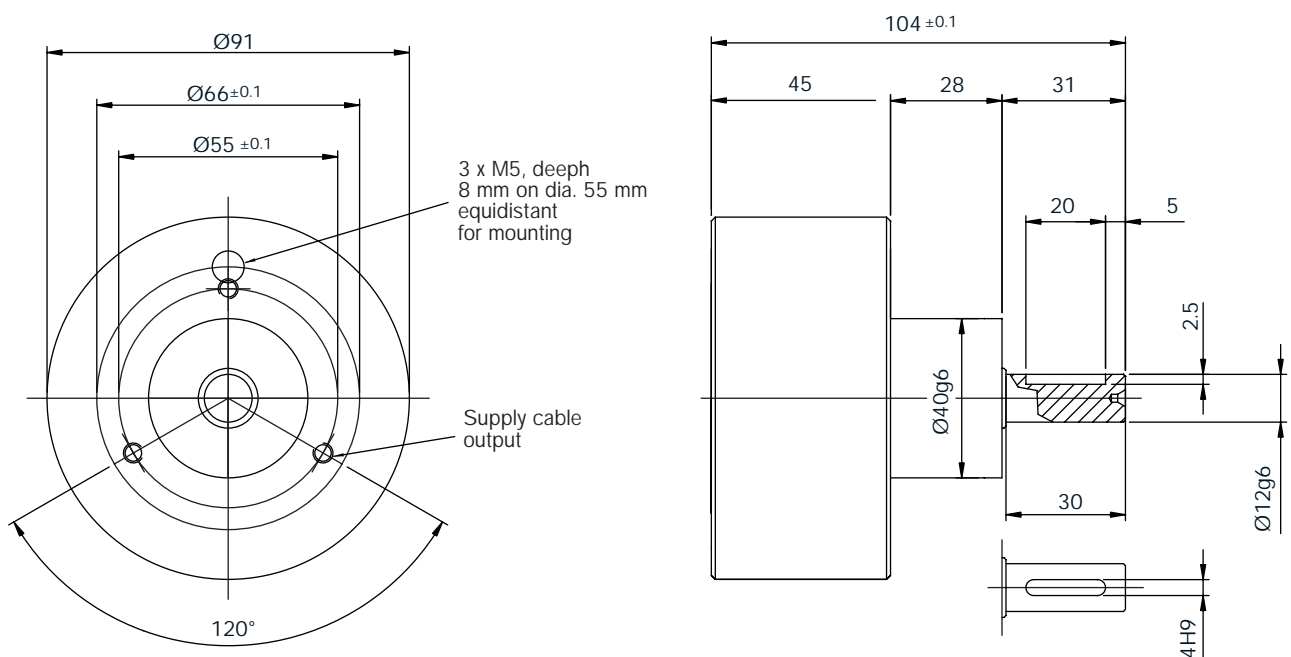

Magnetic particle brakes

BBR5

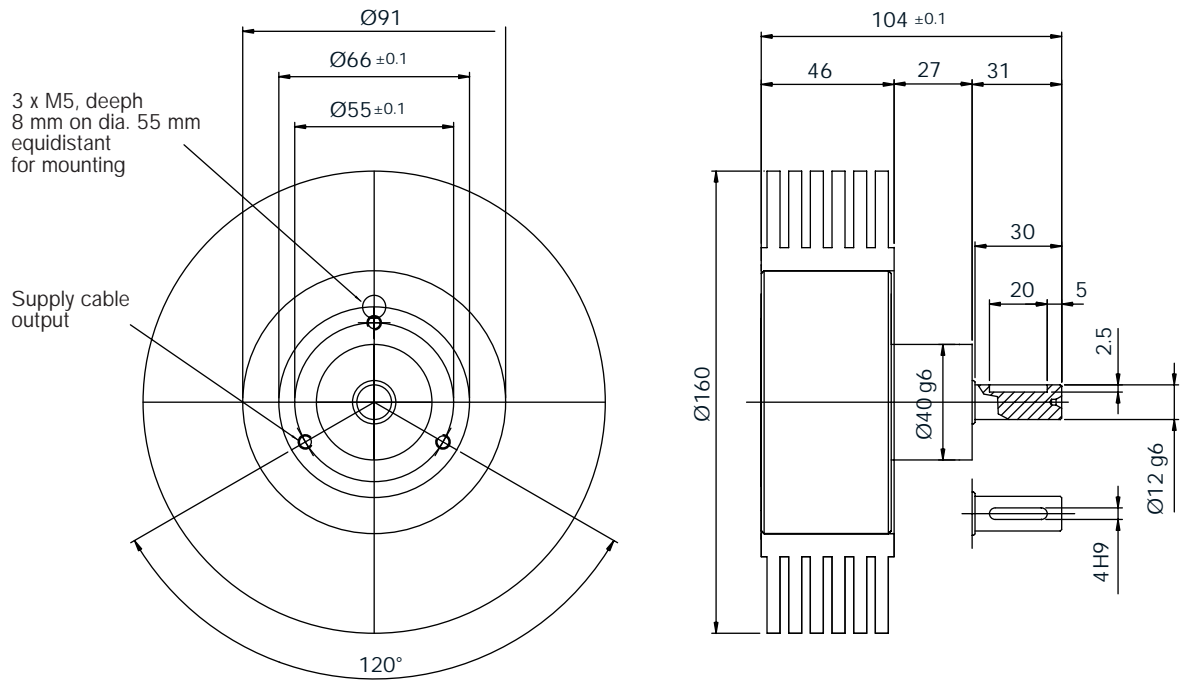

Specifications

Models		BBR5	BB12-1
Maximum torque	Nm	5	12
Residual torque	Nm	-	0,3
Voltage	V	24	24
Current	A	1,3	0,9

Attention : For a correct use of the brake, the operating temperature must not be more than 70° C

Models		BBR5	BB12-1
Résistance à 20° C	Ohm	16,5	25
Power dissipation	W	160	100
Weight	kg	2,2	2,5

BB12-1

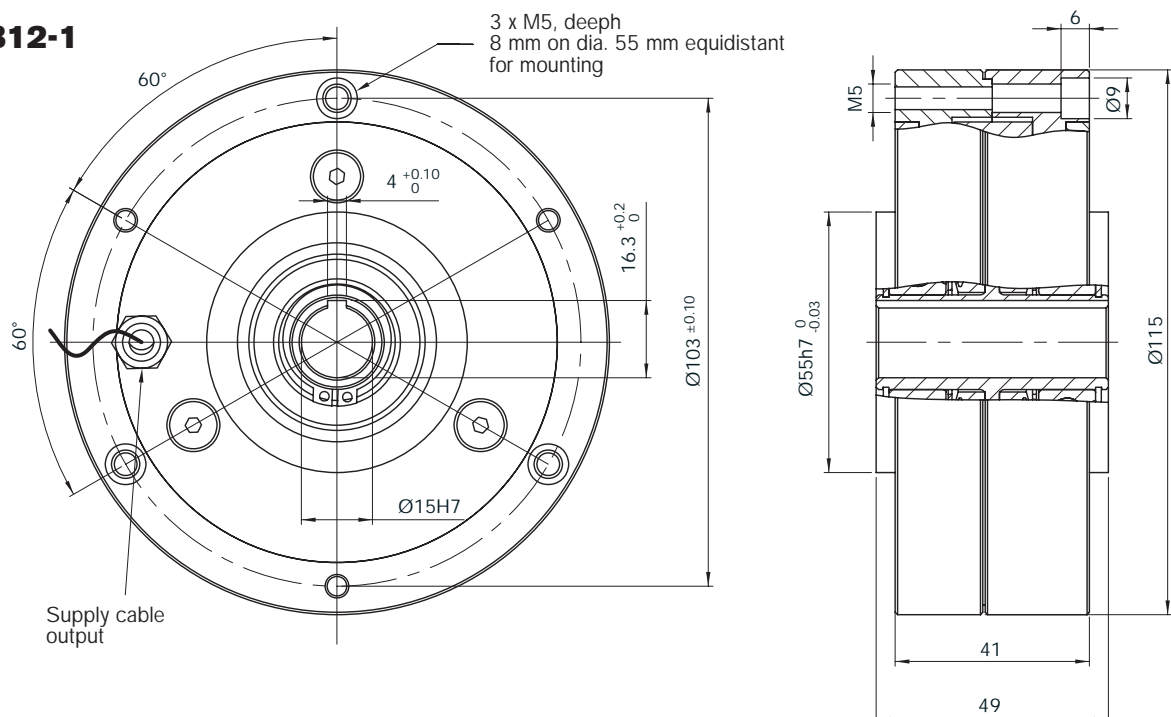

Magnetic particle brakes

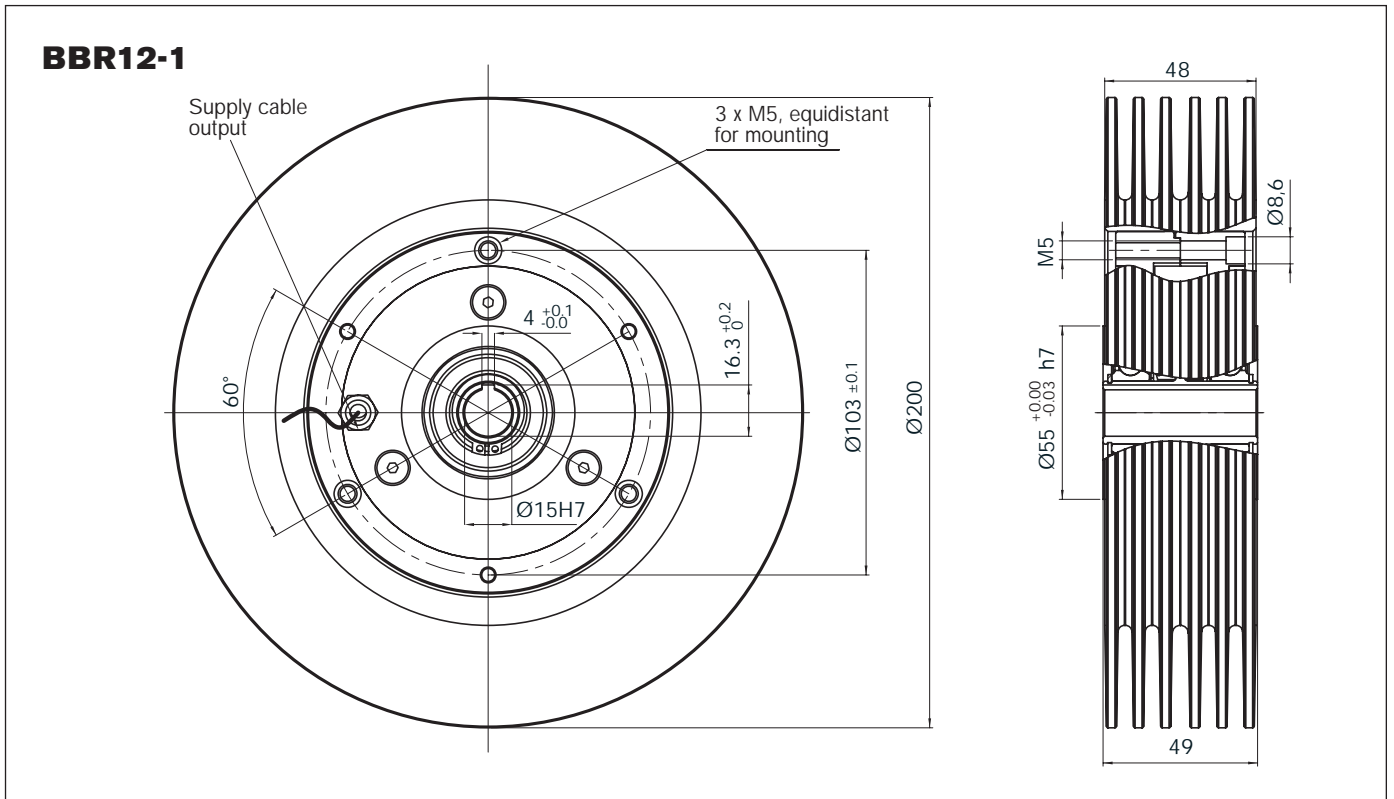

Specifications

Attention : For a correct use of the brake, the operating temperature must not be more than 70° C

Models		BBR12-1	BBV12-1
Maximum torque	Nm	12	12
Residual torque	Nm	0,3	0,3
Voltage	V	24	24
Current	A	0,9	0,9

Models		BBR12-1	BBV12-1
Resistance at 20° C	Ohm	25	25
Power dissipation	W	200	400
Weight	kg	4,3	4,7
Fan tension	V	-	24 VDC, 115/230 AC

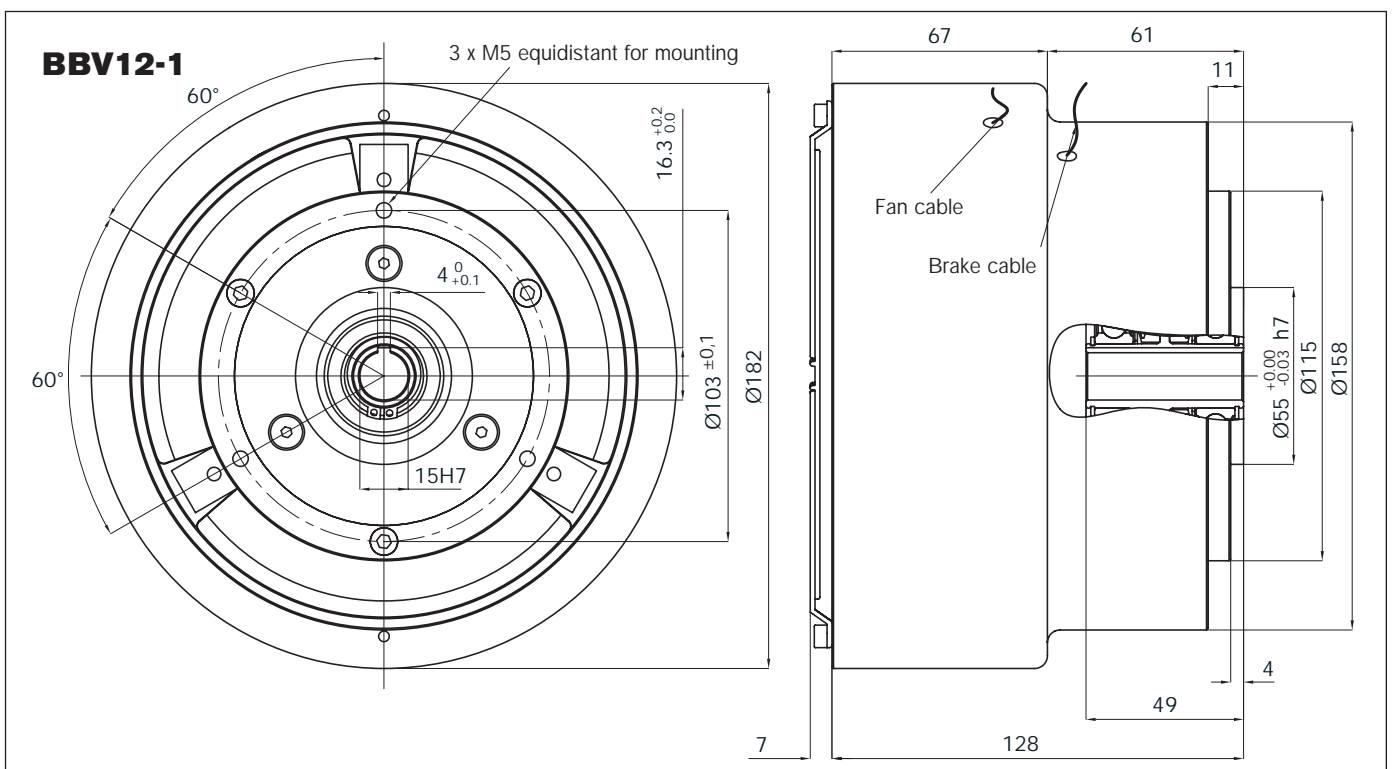

Magnetic particle brakes

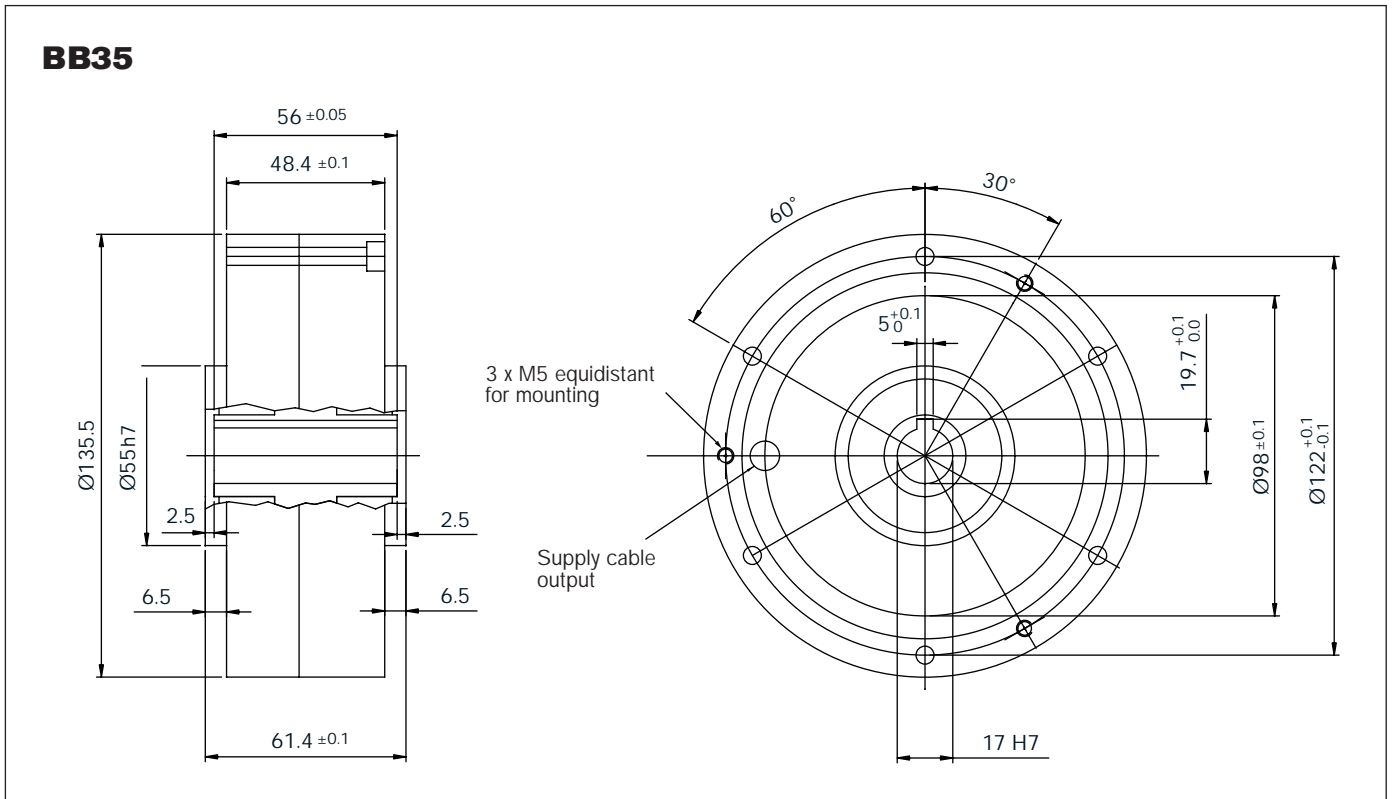

Specifications

Models		BB35	BBR35
Maximum torque	Nm	35	35
Residual torque	Nm	0,4	0,4
Voltage	V	24	24
Current	A	0,9	0,9

Attention : For a correct use of the brake, the operating temperature must not be more than 70° C

Modèles		BB35	BBR35
Resistance at 20° C	Ohm	20	20
Power dissipation	W	150	280
Weight	kg	4,3	7,3

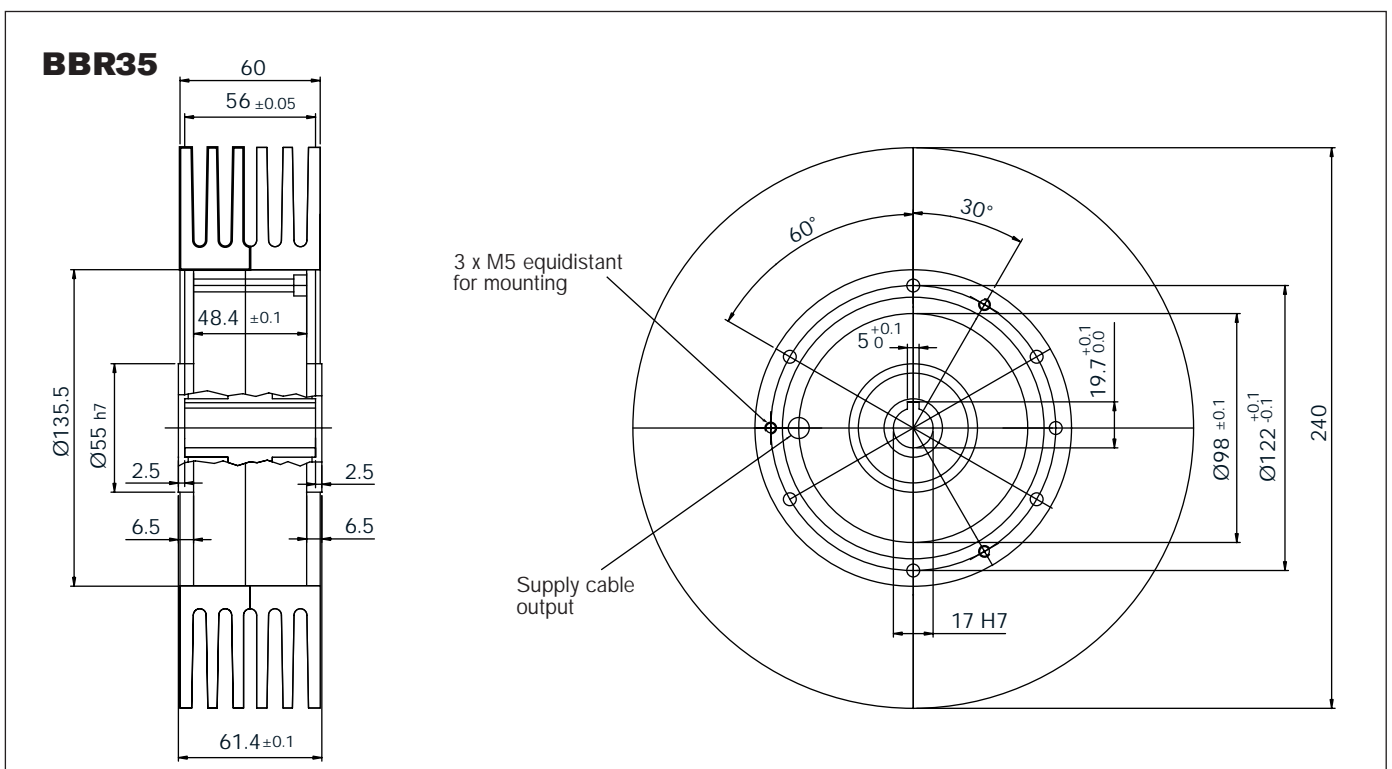

Magnetic particle brakes

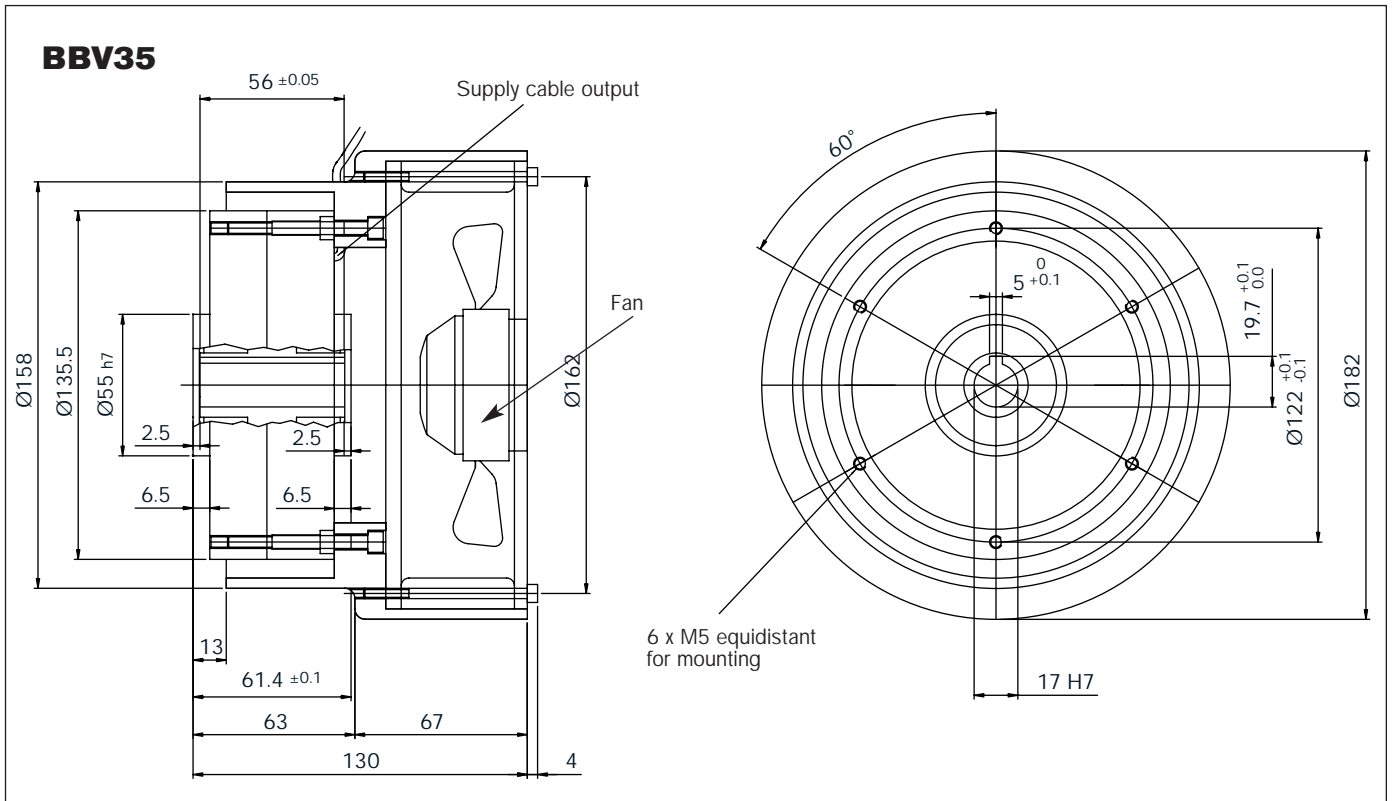

Specifications

Attention : For a correct use of the brake, the operating temperature must not be more than 70° C

Models		BBV35	BB65-1
Maximum torque	Nm	35	65
Residual torque	Nm	0,4	0,4
Voltage	V	24	24
Current	A	0,9	1

Models		BBV35	BB65-1
Resistance at 20° C	Ohm	20	24
Power dissipation	W	600	400
Weight	kg	6,4	9
Fan tension	V	24 VDC, 115/230 AC	-

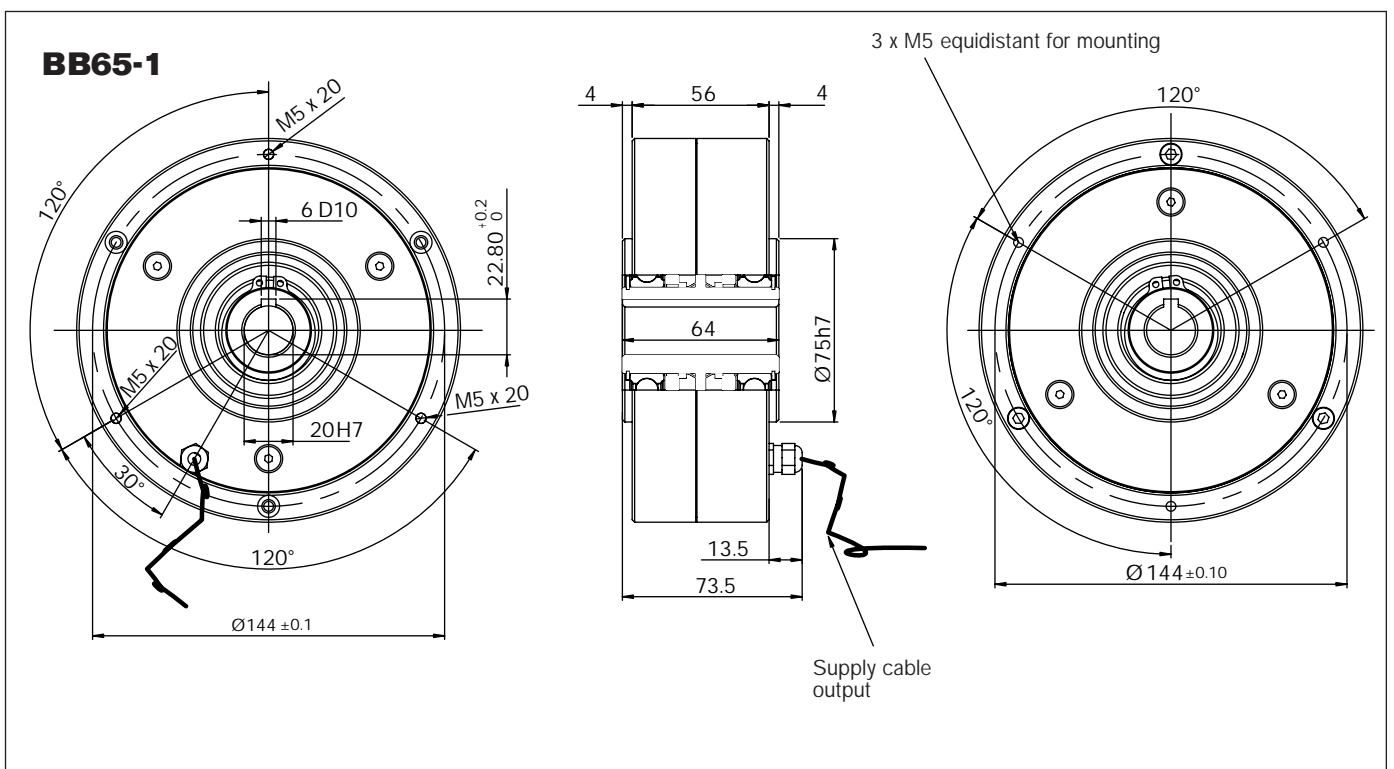

Magnetic particle brakes

BBR65-1

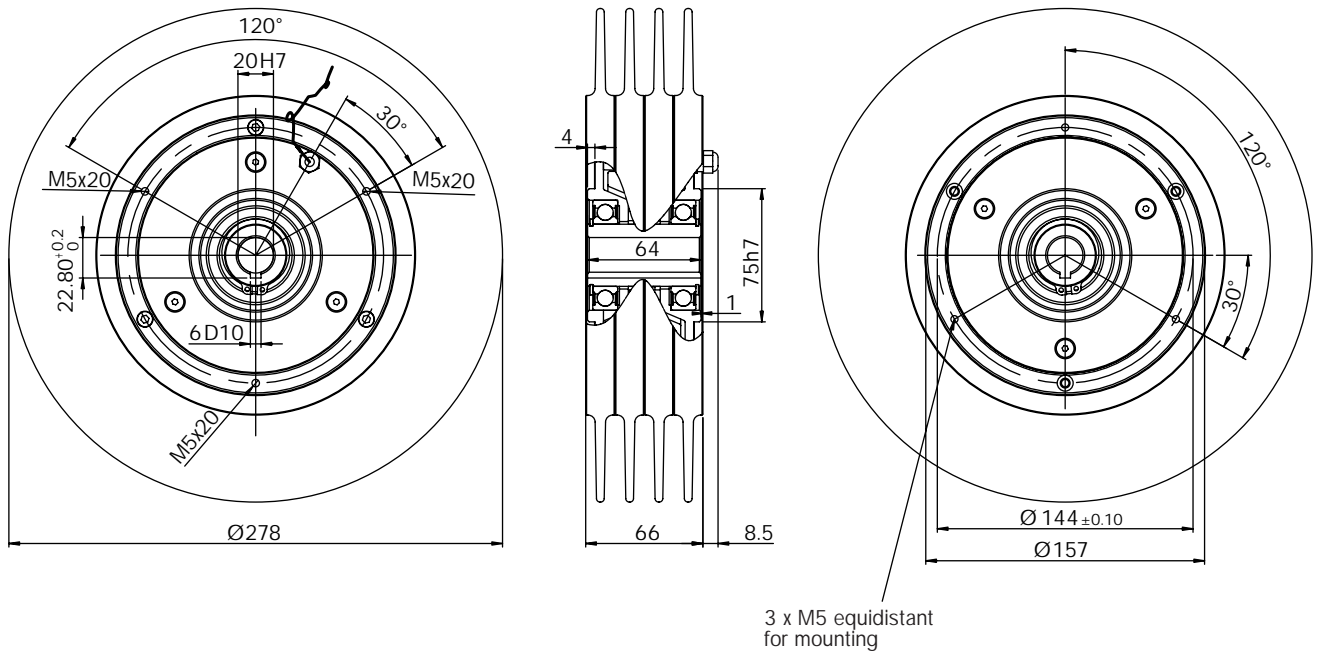

Specifications

Attention : For a correct use of the brake, the operating temperature must not be more than 70° C

Models		BBR65-1	BBV65-1
Maximum torque	Nm	65	65
Residual torque	Nm	0,4	0,4
Voltage	V	24	24
Current	A	0,95	1

Models		BBR65-1	BBV65-1
Resistance at 20° C	Ohm	24	24
Power dissipation	W	400	800
Weight	kg	9,8	8,8
Fan tension	V	-	24 VDC, 115/230 AC

BBV65-1

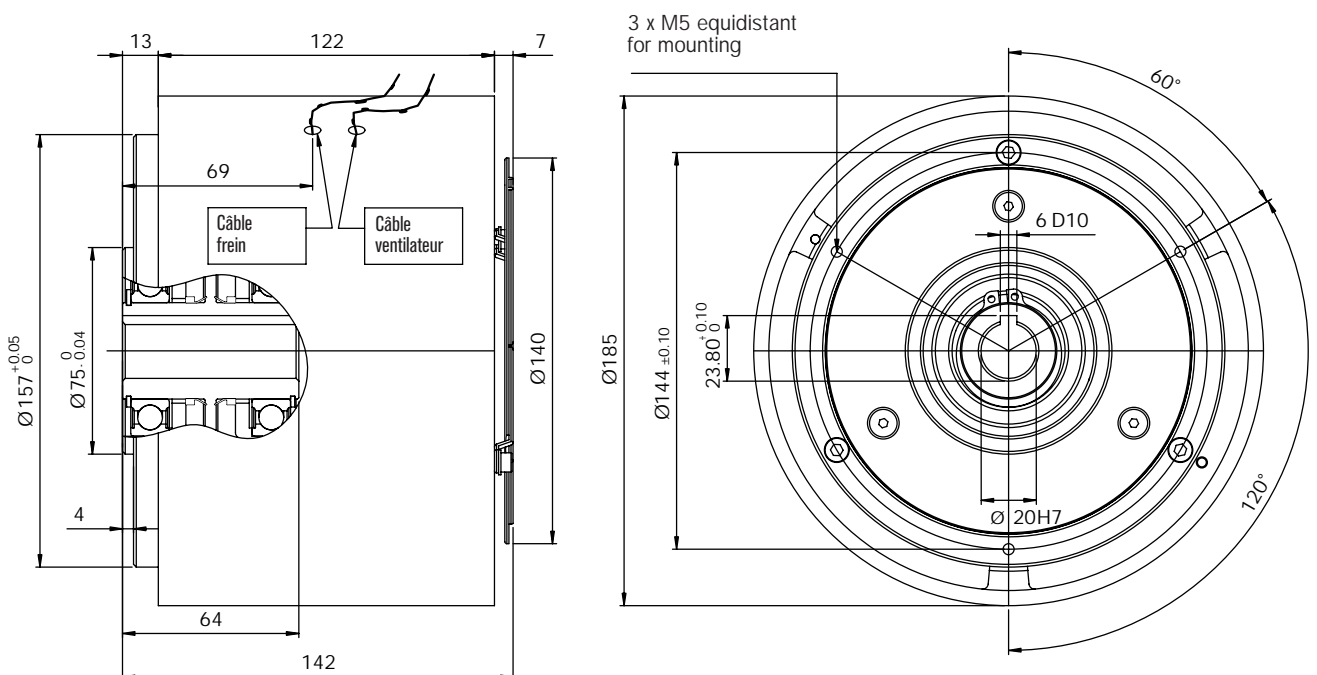

Magnetic particle brakes

BB120-1

* 5mm/old ref. BB120

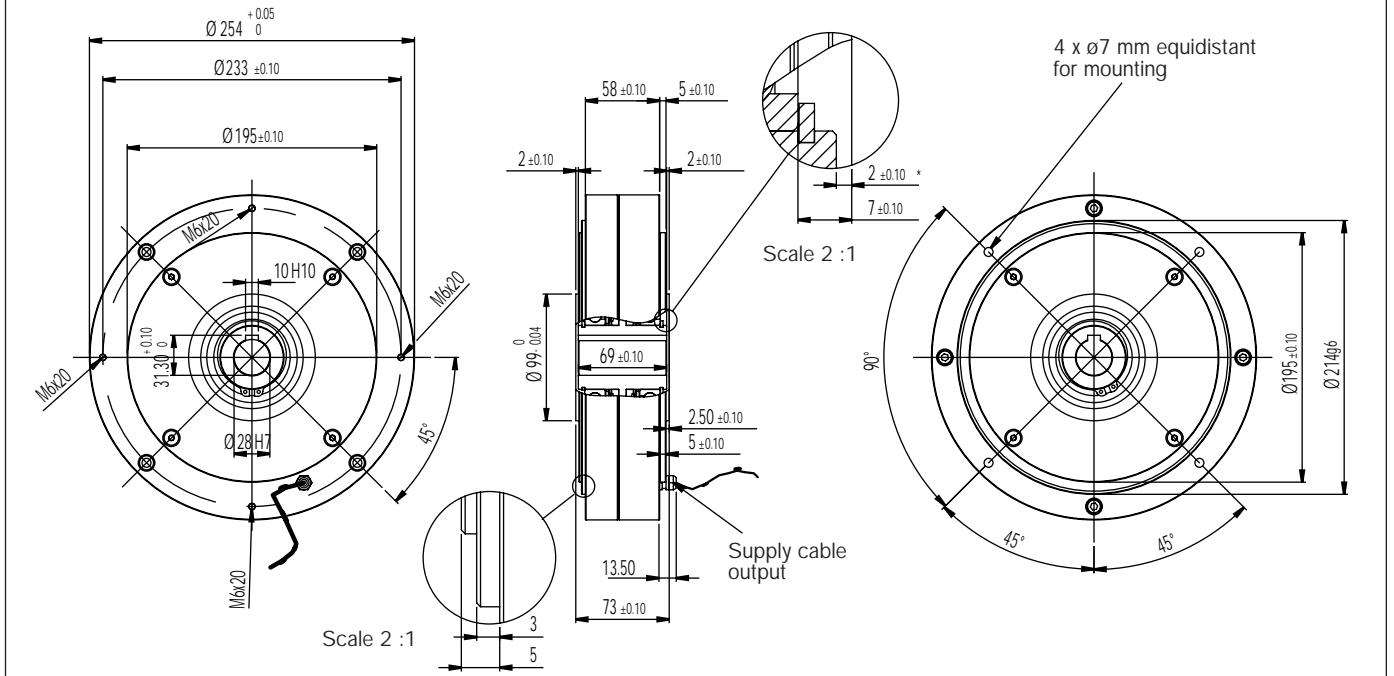

Specifications

Attention : For a correct use of the brake, the operating temperature must not be more than 70° C

Models		BB120-1	BBR120-1
Maximum torque	Nm	120	120
Residual torque	Nm	0,6	0,6
Voltage	V	24	24
Current	A	2	2

Models		BB120-1	BBR120-1
Resistance at 20° C	Ohm	11	11
Power dissipation	W	400	800
Weight	kg	18	23

BBR120-1

* 5mm/old ref. BBR120

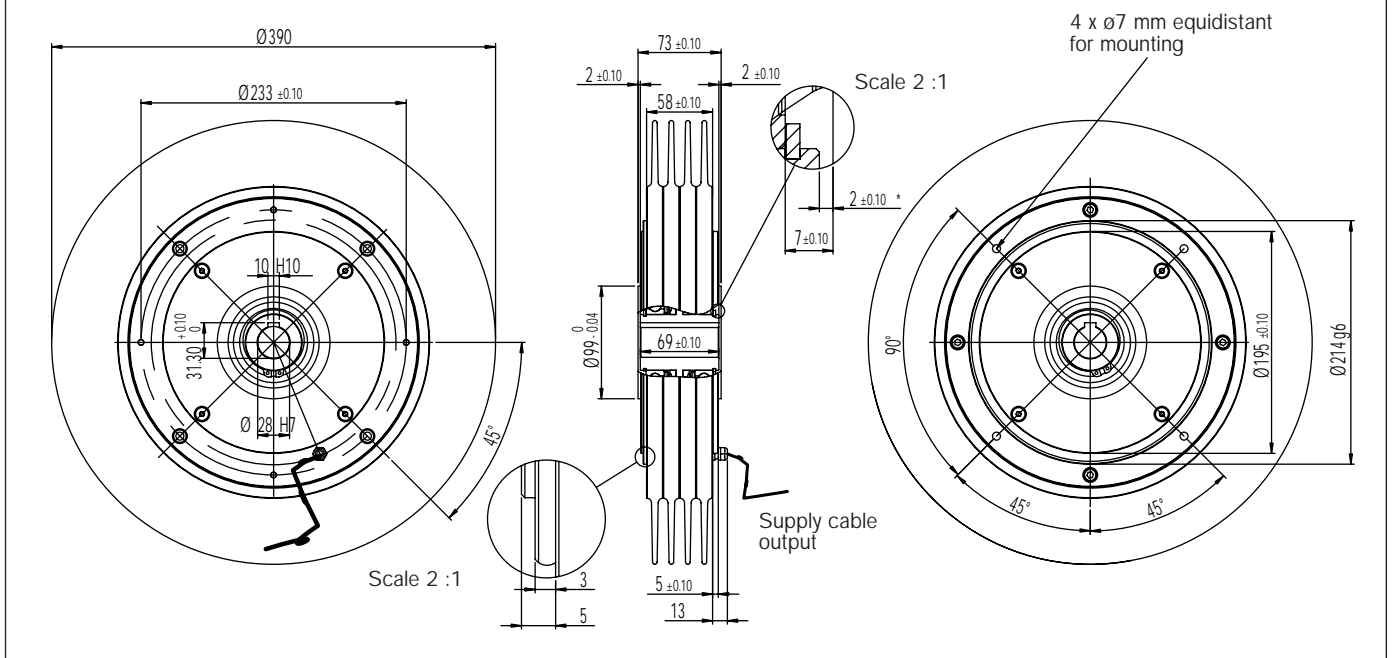

Magnetic particle brakes

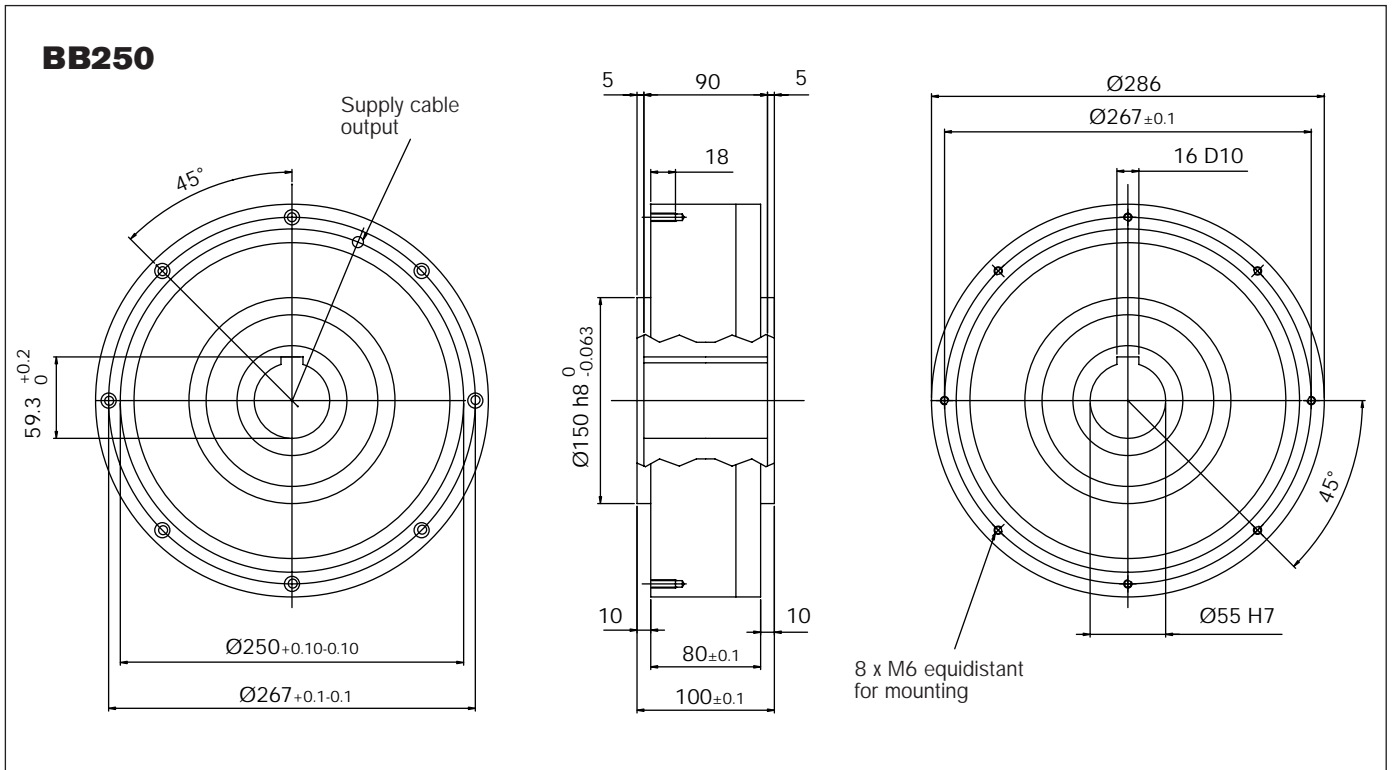

Specifications

Models		BB250	BBR250
Maximum torque	Nm	250	250
Residual torque	Nm	1	1
Voltage	V	24	24
Current	A	1,1	1,1

Attention : For a correct use of the brake, the operating temperature must not be more than 70° C

Models		BB250	BBR250
Resistance at 20° C	Ohm	22	22
Power dissipation	W	600	1200
Weight	kg	32	38

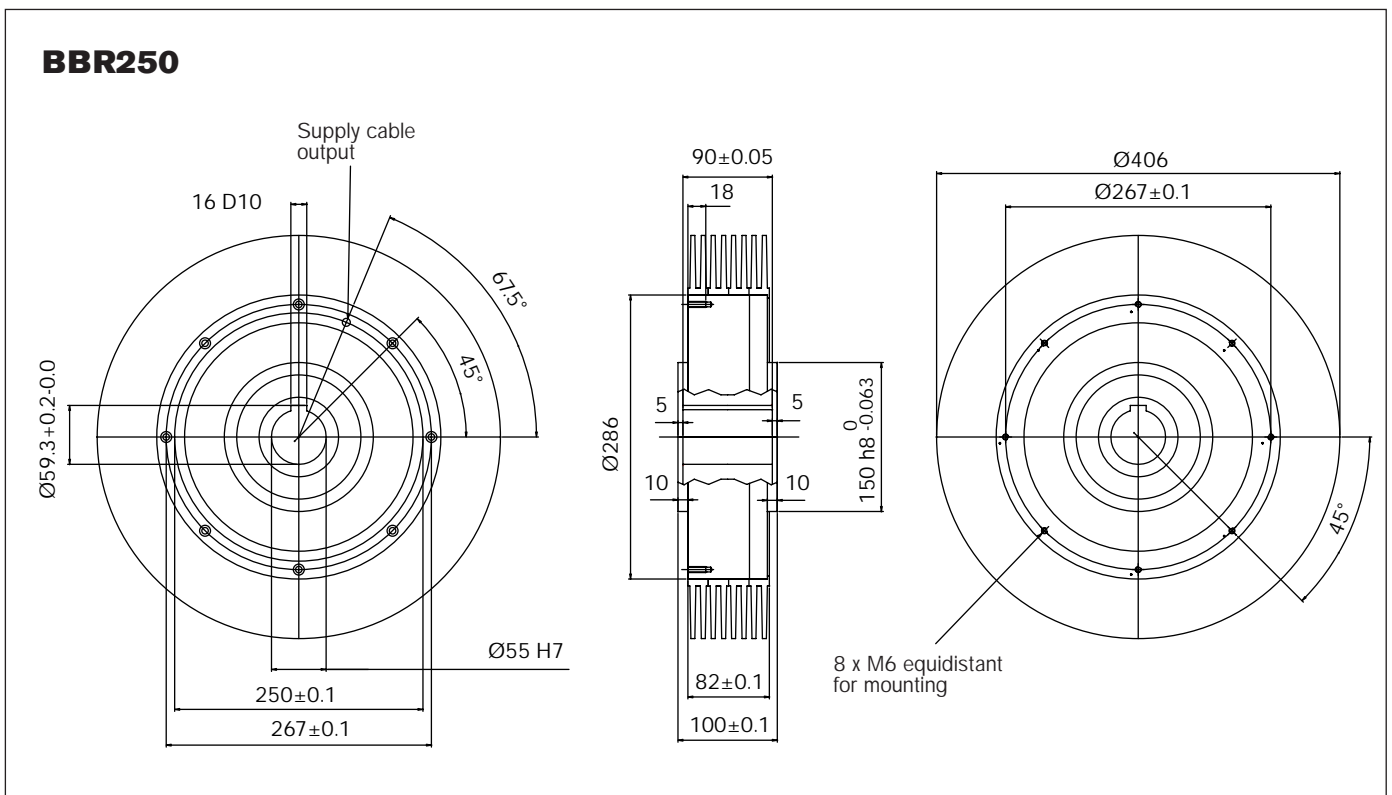

Magnetic particle brakes

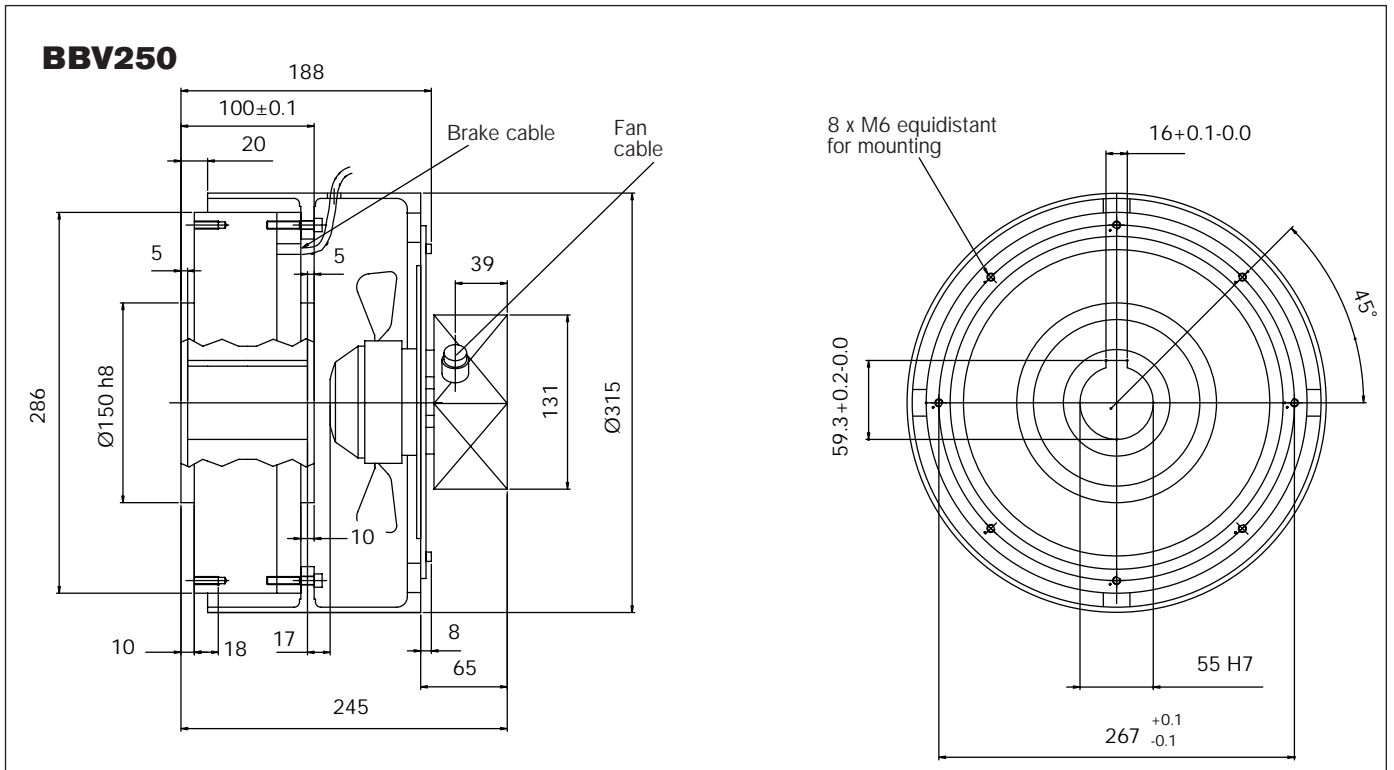

Specifications

Attention : For a correct use of the brake, the operating temperature must not be more than 70° C

Models		BBV250	BB500
Maximum torque	Nm	250	500
Residual torque	Nm	1	1
Voltage	V	24	24
Current	A	1,1	0,9

Models		BBV250	BB500
Resistance at 20° C	Ohm	22	27
Power dissipation	W	2400	1600
Weight	kg	38	59
Fan tension	V	24 VDC, 115/230 AC	-

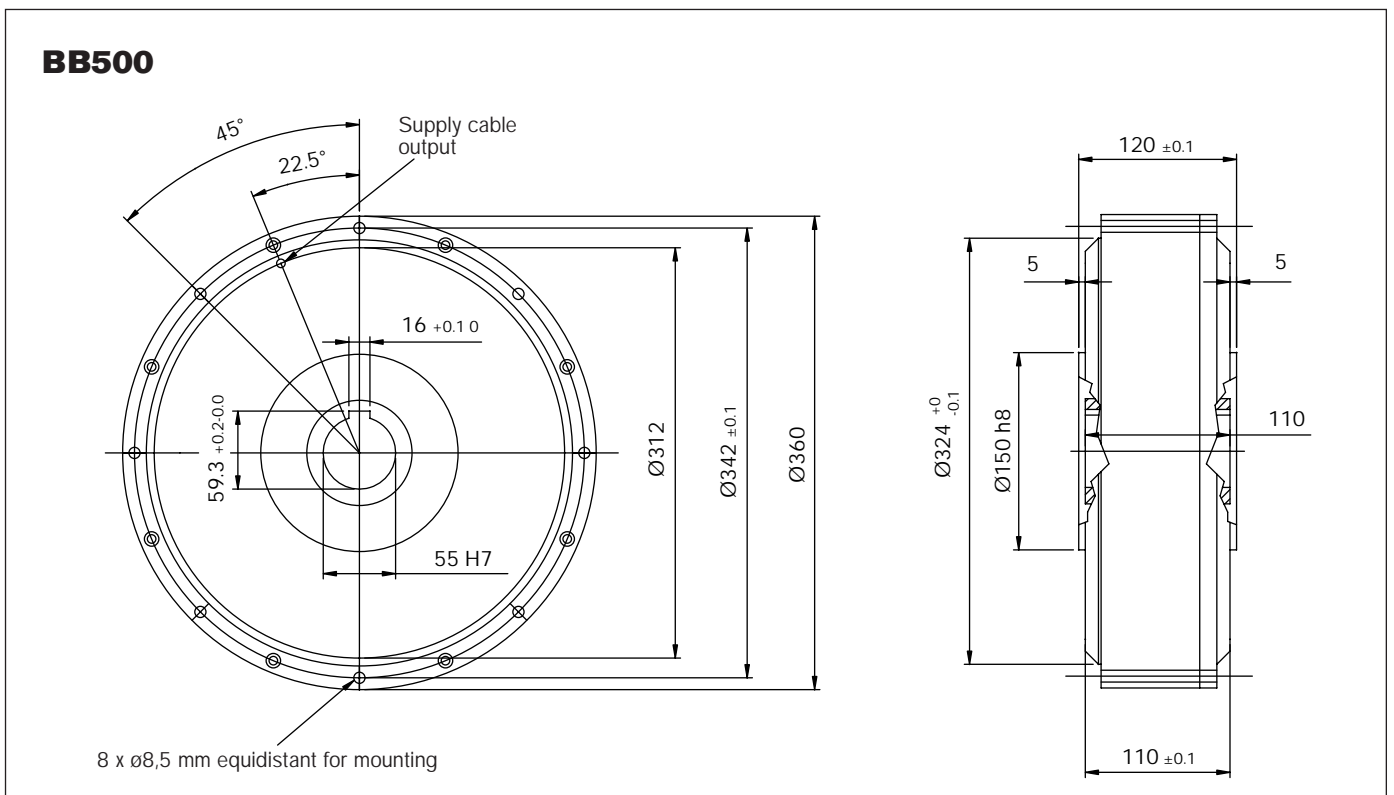

Magnetic particle brakes

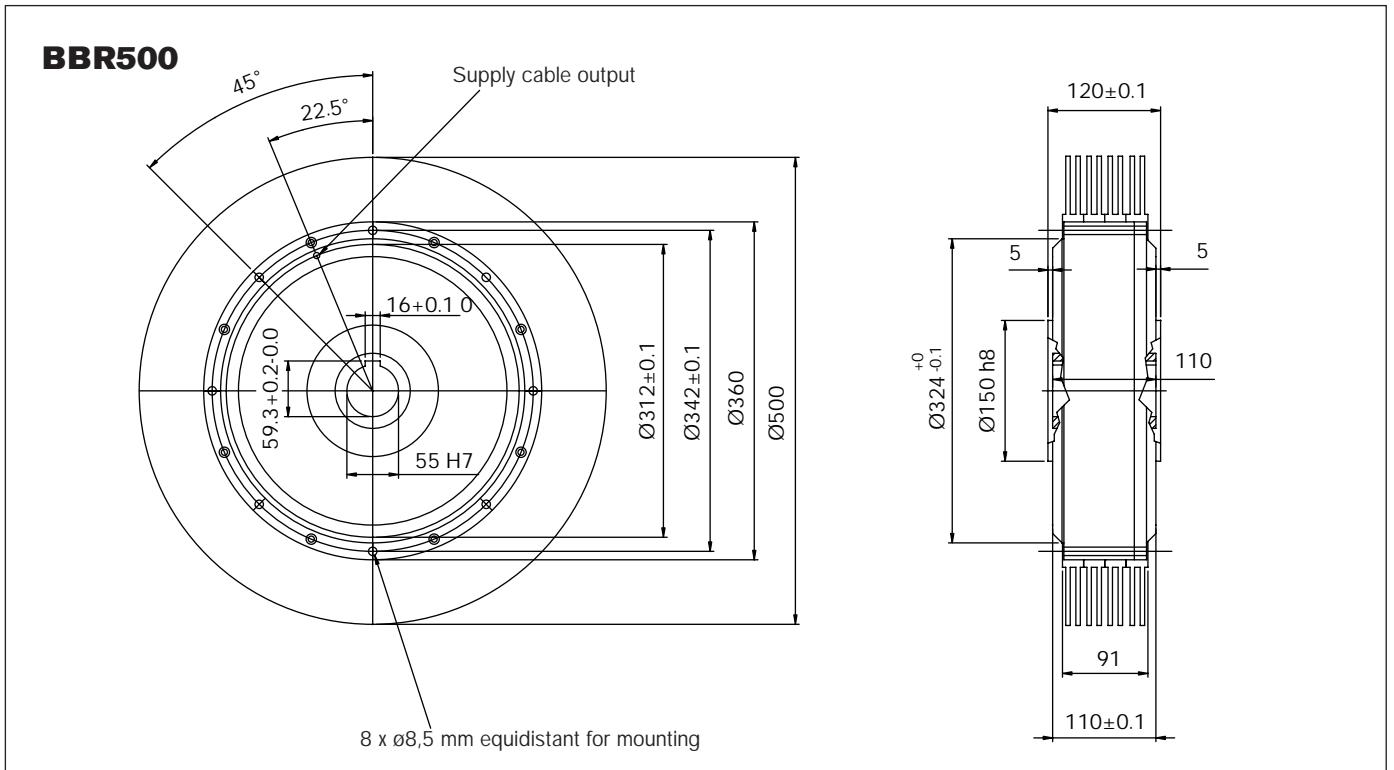

Specifications

Models		BBR500	BBV500
Maximum torque	Nm	500	500
Residual torque	Nm	1	1
Voltage	V	24	24
Current	A	0,9	0,9

Attention : For a correct use of the brake, the operating temperature must not be more than 70° C

Models		BBR500	BBV500
Resistance at 20° C	Ohm	27	27
Power dissipation	W	3200	4800
Weight	kg	62	62
Fan tension	V	-	24 VDC, 115/230 AC

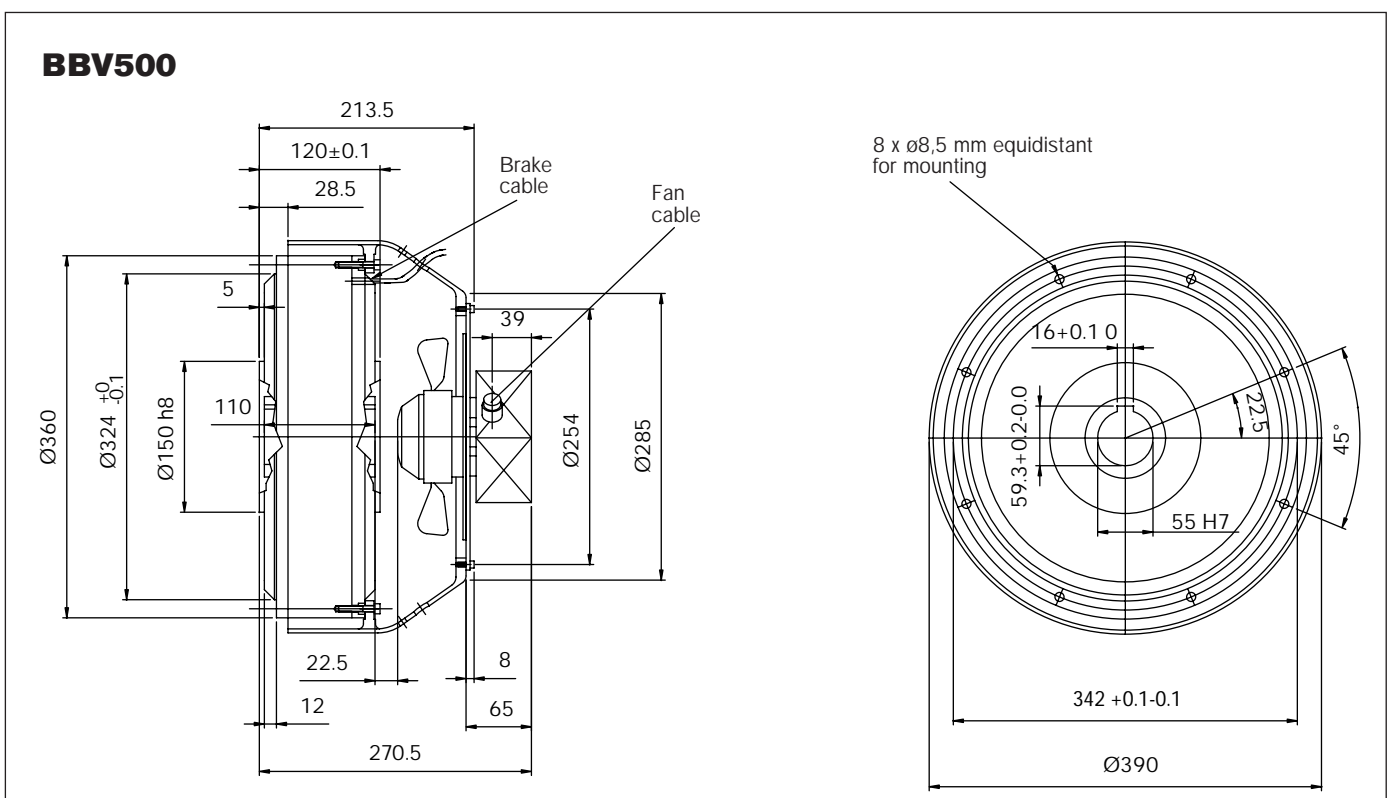

Magnetic particle clutches

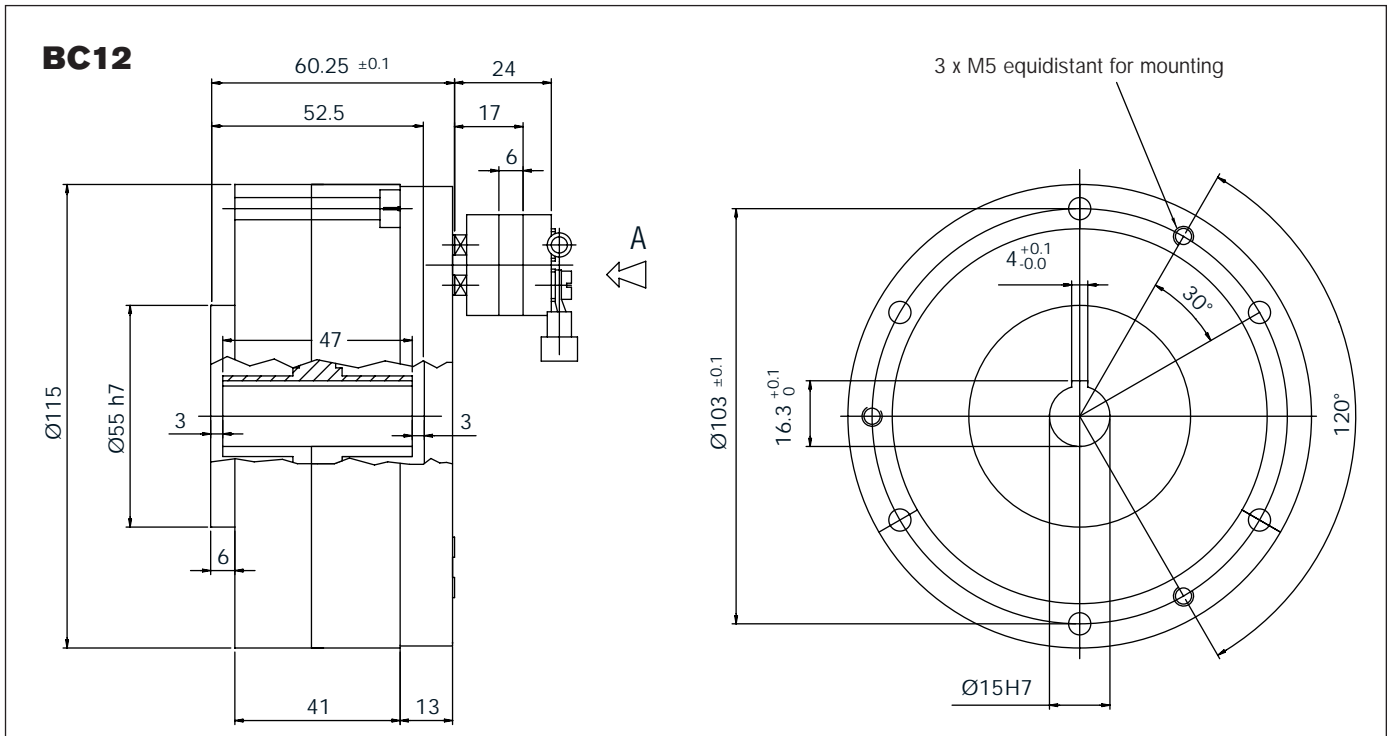

Specifications Attention : the operating temperature must not be more than 70° C

Models		BC12	BCR12
Maximum torque	Nm	12	12
Residual torque	Nm	0,3	0,3
Voltage	V	24	24
Current	A	0,9	0,9
Resistance at 20° C	Ohm	25	25
Power dissipation at 500 RPM	W	120	440
Power dissipation at 1000 RPM	W	150	550
Weight	kg	2,8	4,6

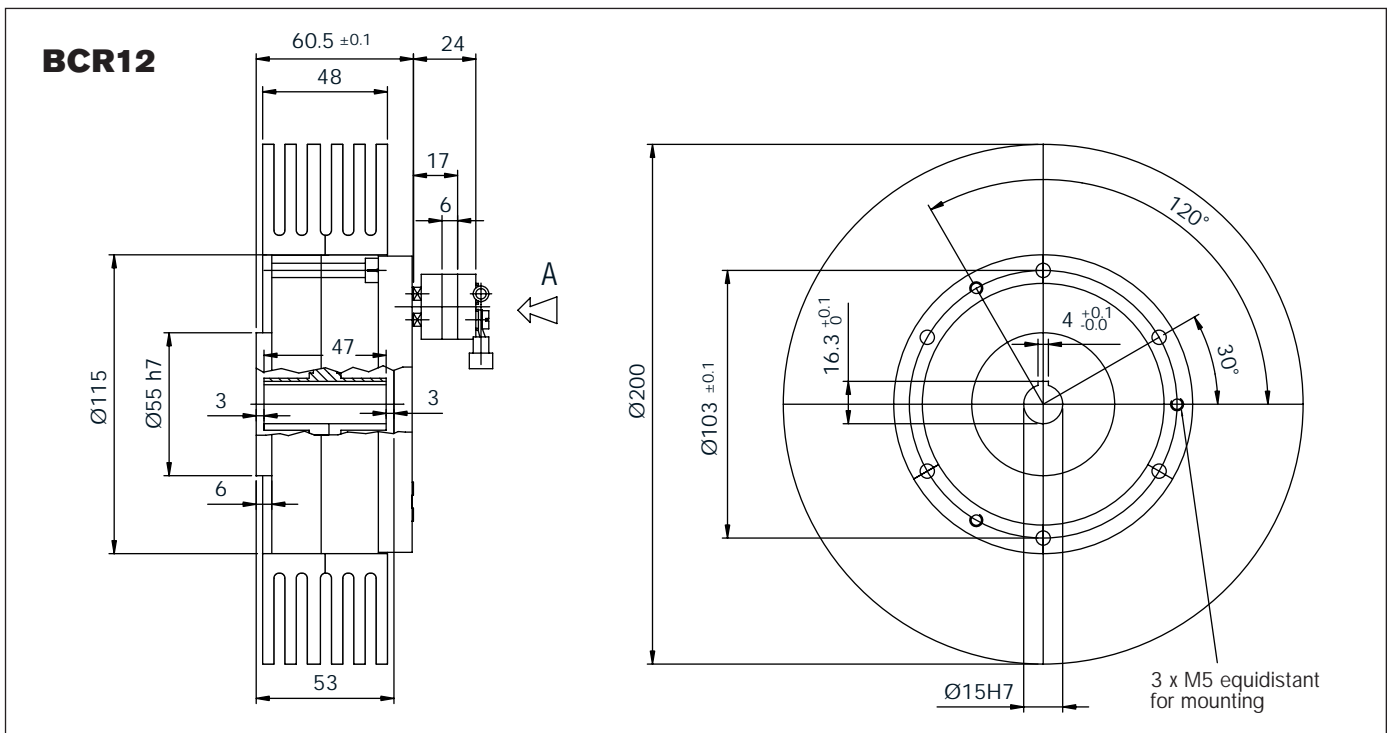
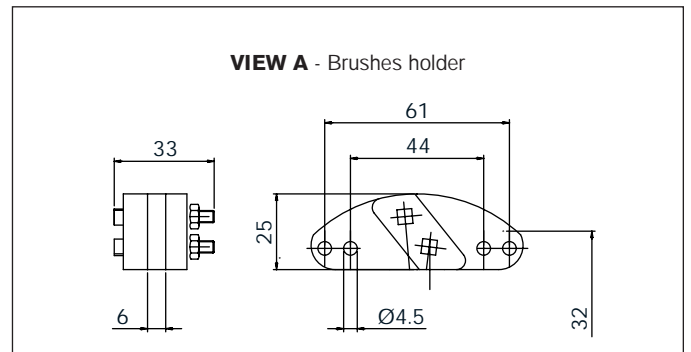

Magnetic particle clutches

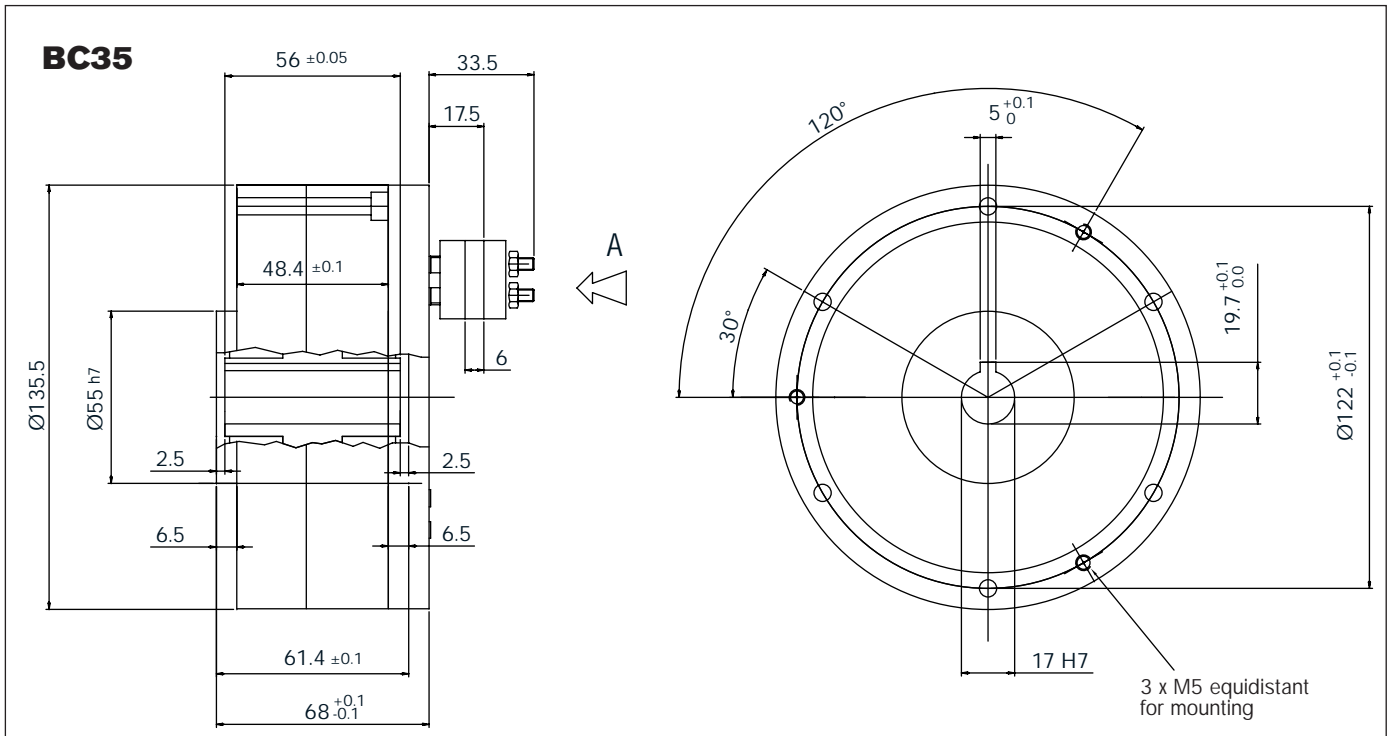

Specifications Attention : the operating temperature must not be more than 70° C

Models		BC35	BCR35
Maximum torque	Nm	35	35
Residual torque	Nm	0,4	0,4
Voltage	V	24	24
Current	A	0,9	0,9
Resistance at 20° C	Ohm	20	20
Power dissipation at 500 RPM	W	200	640
Power dissipation at 1000 RPM	W	250	800
Weight	kg	4,7	7,7

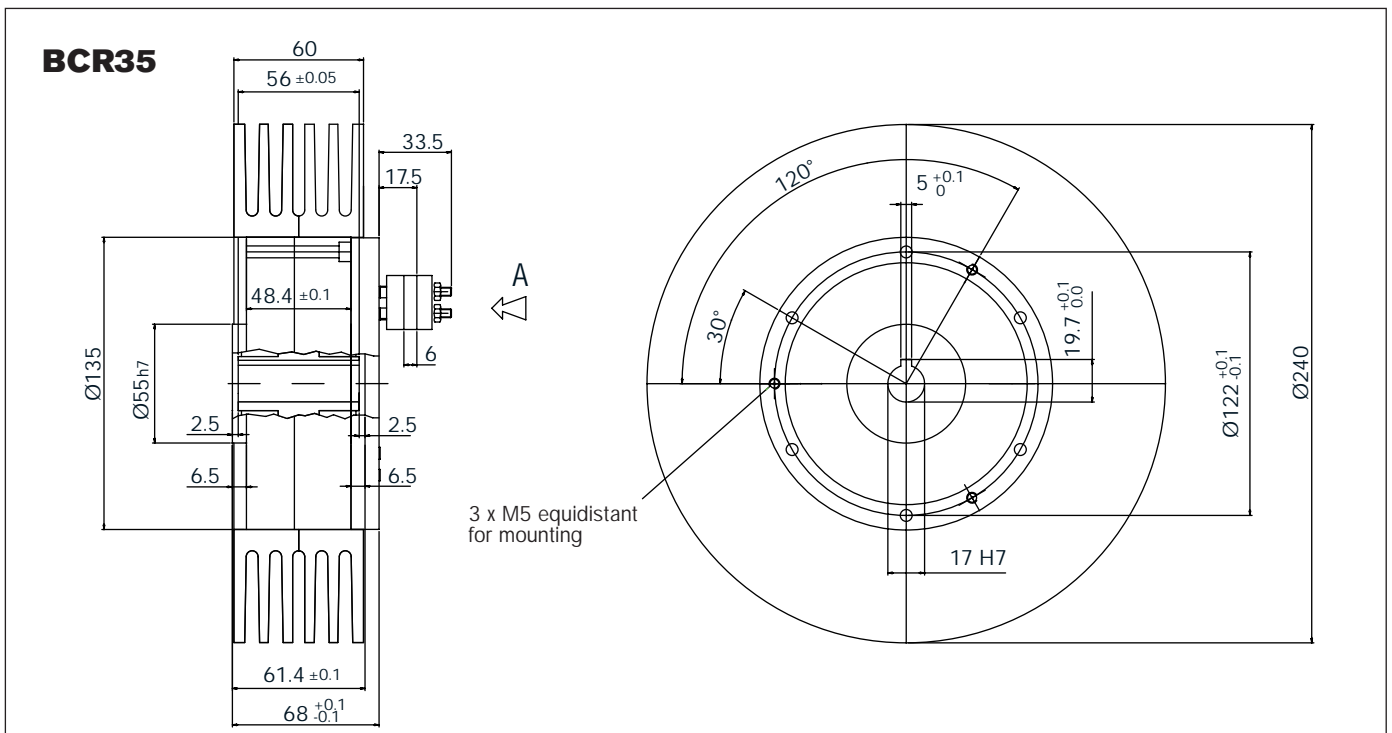
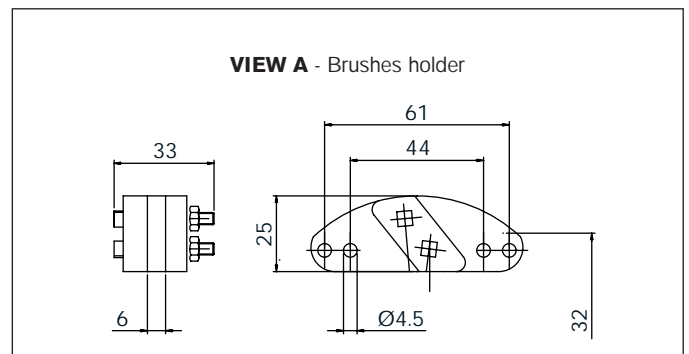

Magnetic particle clutches

BC65-1

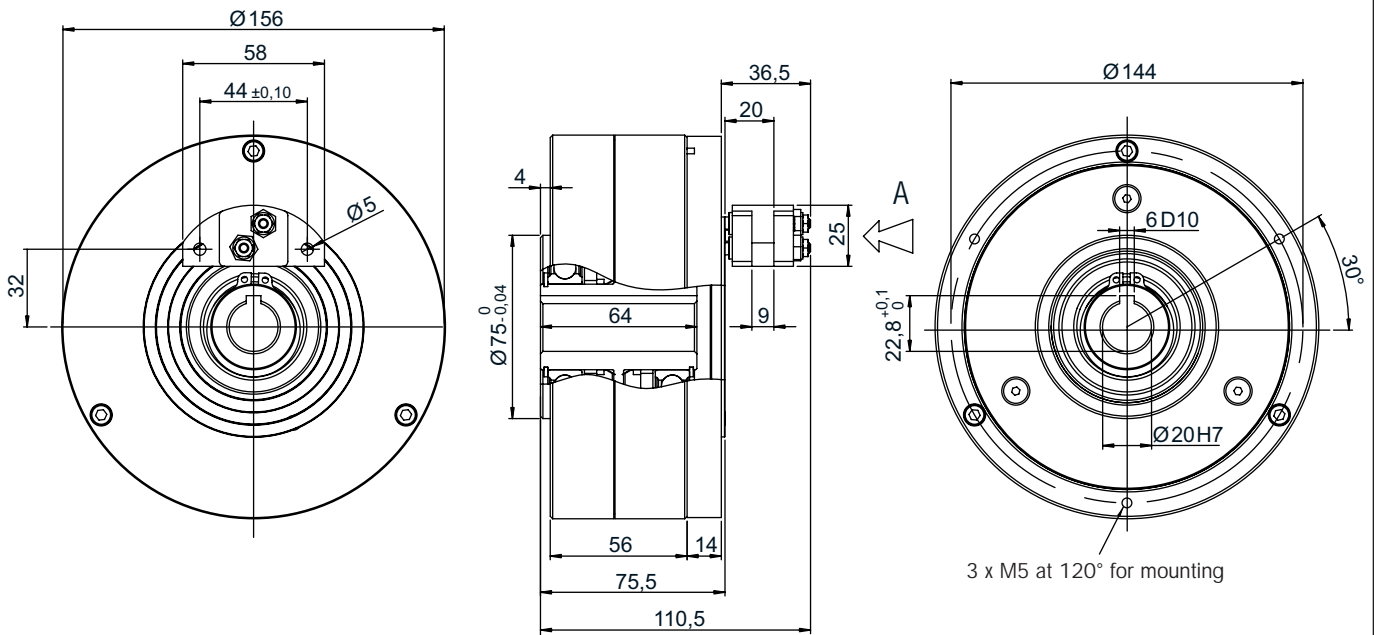

Specifications **Attention :** the operating temperature must not be more than $70^\circ C$

Models		BC65-1	BCR65-1
Maximum torque	Nm	65	65
Residual torque	Nm	0,4	0,4
Voltage	V	24	24
Current	A	1	1
Resistance at $20^\circ C$	Ω	24	24
Power dissipation at 500 RPM	W	280	960
Power dissipation at 1000 RPM	W	350	1200
Weight	kg	7,5	10,5

VIEW A - Brushes holder

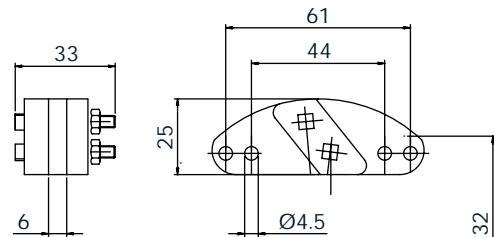

BCR65-1

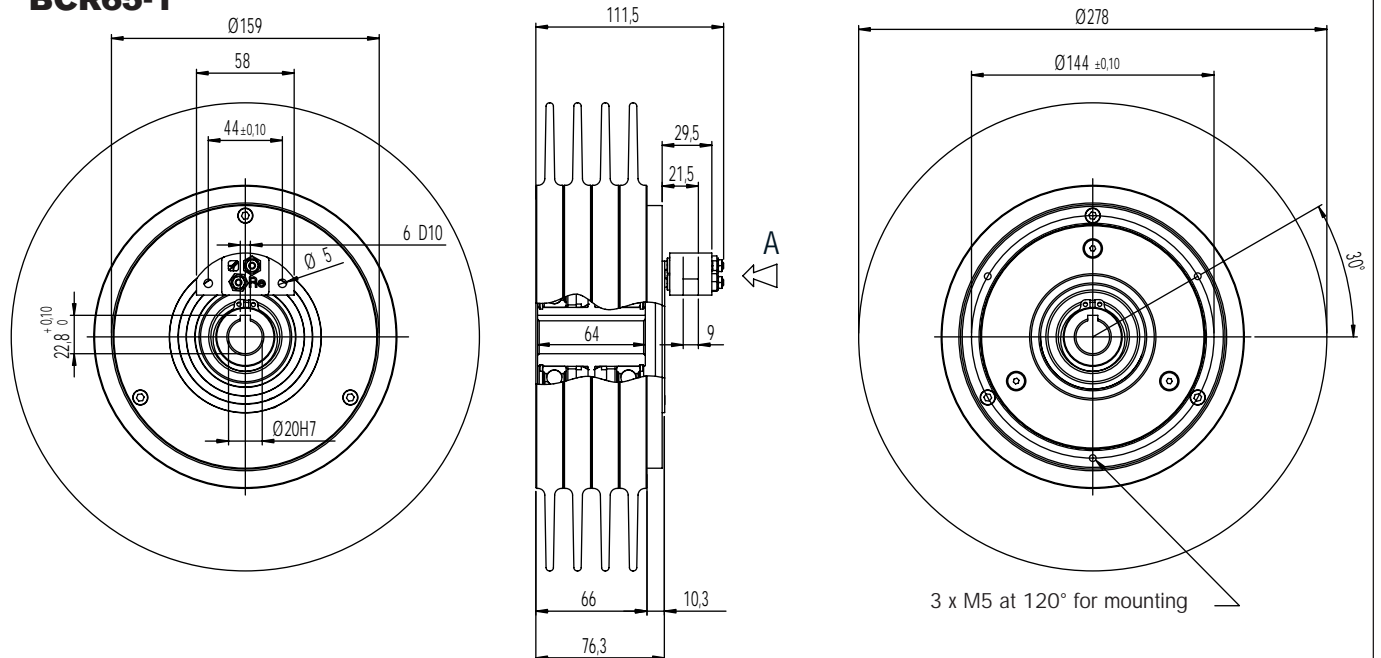

Magnetic particle clutches

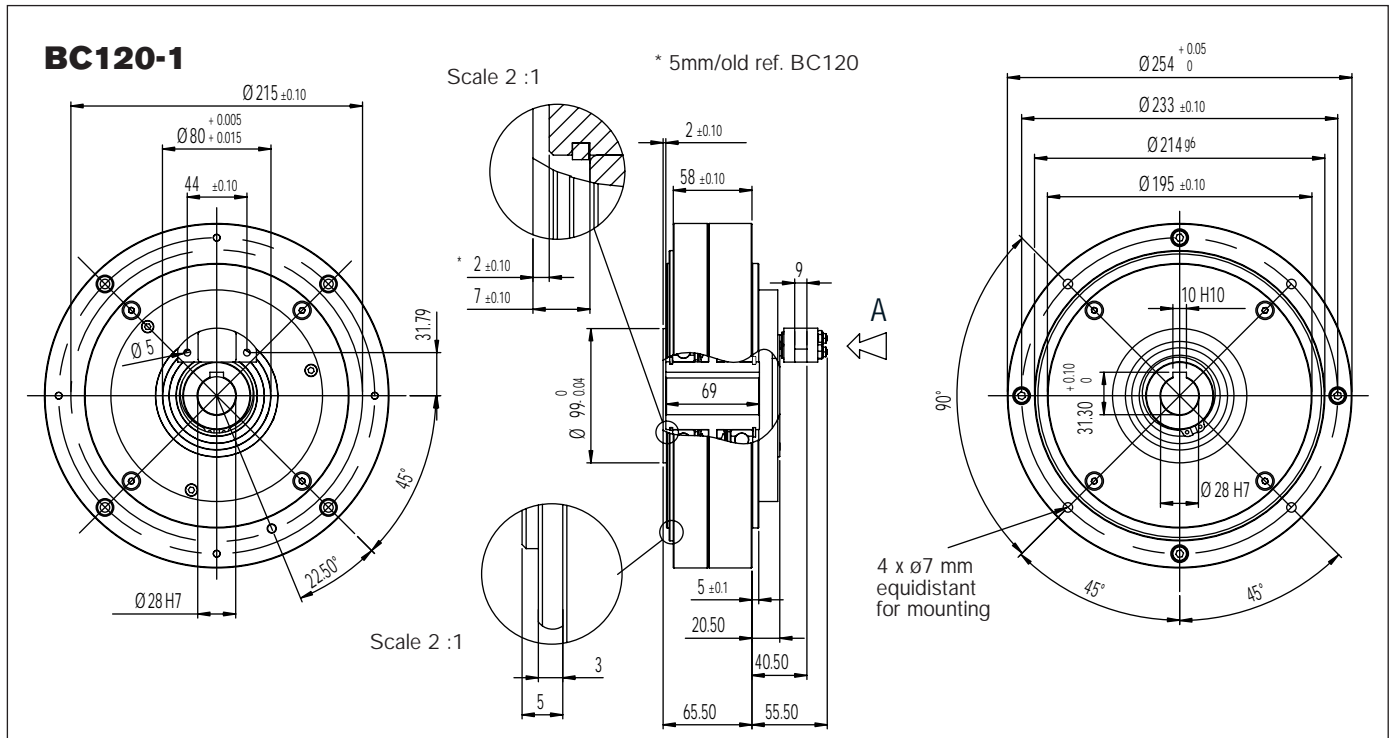

Specifications

Attention : the operating temperature must not be more than 70° C

Models		BC120-1	BCR120-1
Maximum torque	Nm	120	120
Residual torque	Nm	0,6	0,6
Voltage	V	24	24
Current	A	2	2
Resistance at 20° C	Ohm	11	11
Power dissipation at 500 RPM	W	800	1600
Power dissipation at 1000 RPM	W	1000	2000
Weight	kg	19	24

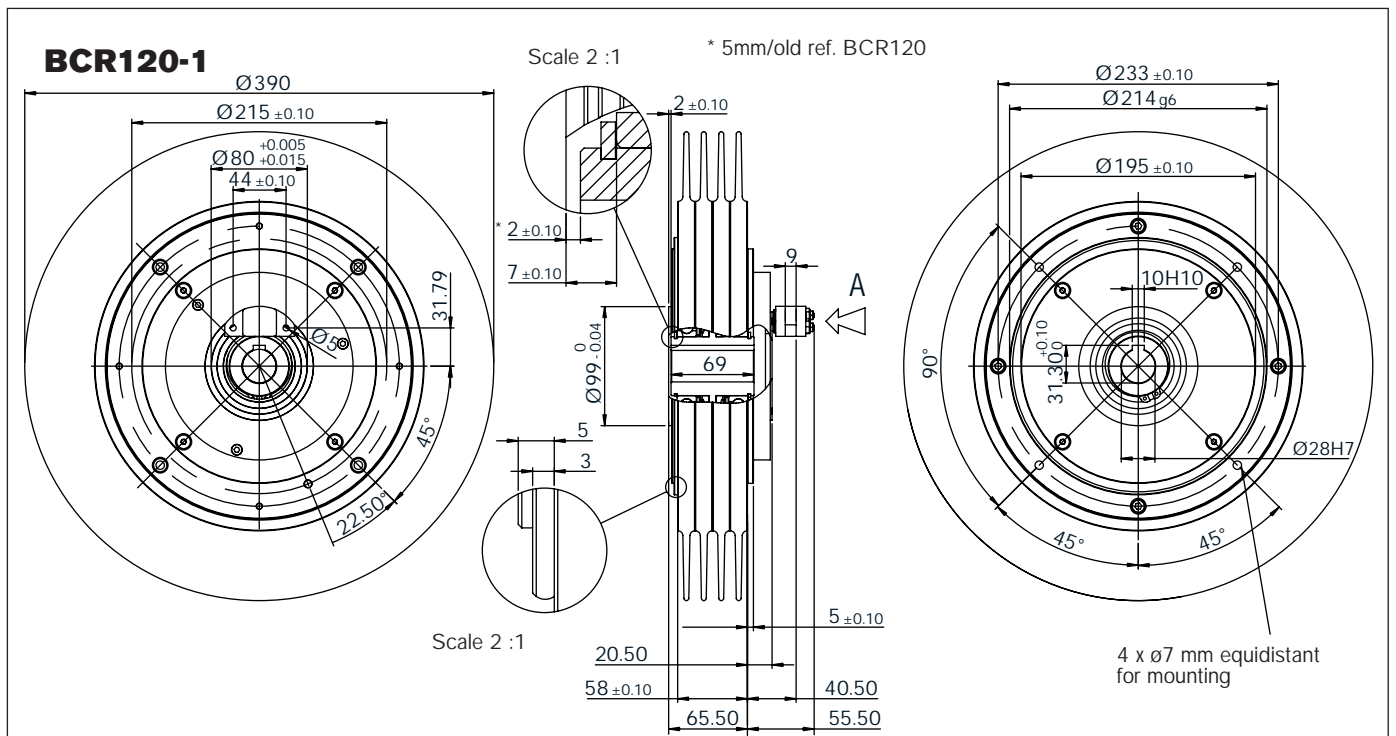
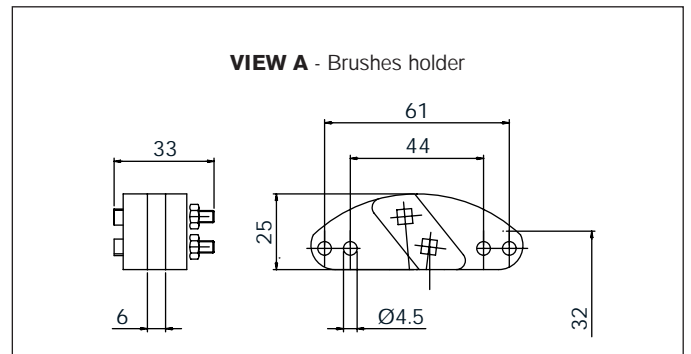

Magnetic particle clutches

BC250

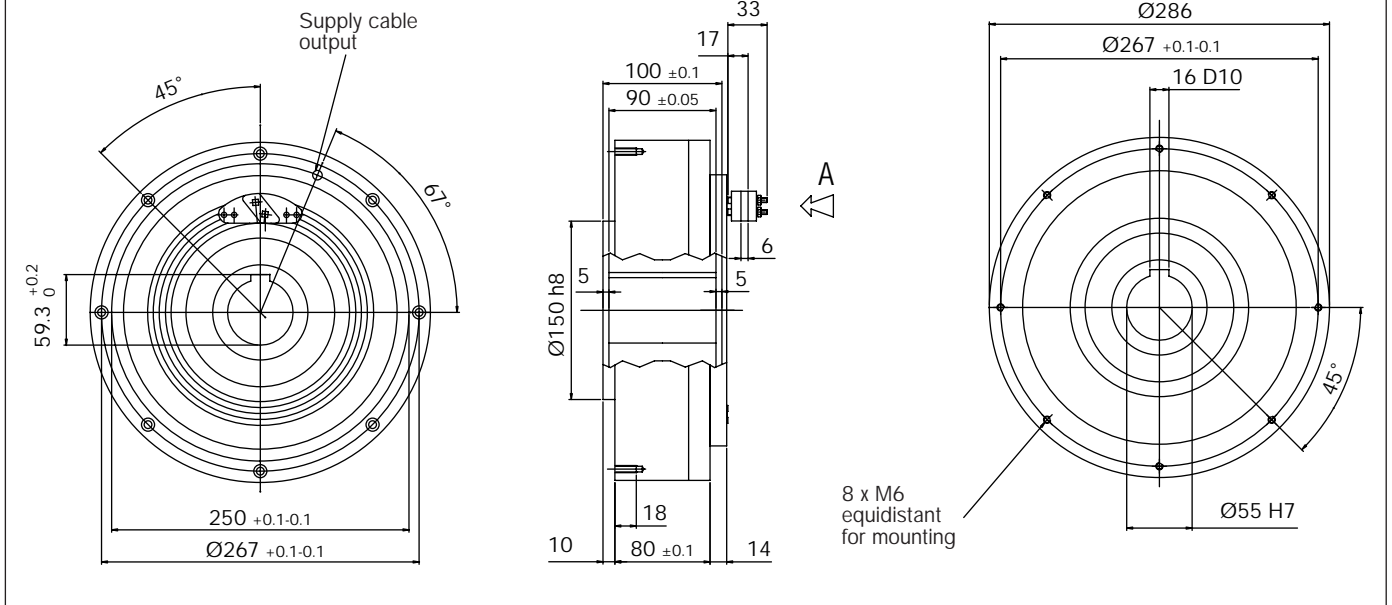

Specifications Attention : the operating temperature must not be more than 70° C

Models		BC250	BCR250
Maximum torque	Nm	250	250
Residual torque	Nm	1	1
Voltage	V	24	24
Current	A	1,1	1,1
Resistance at 20° C	Ohm	22	22
Power dissipation at 500 RPM	W	1440	2600
Power dissipation at 1000 RPM	W	1800	3250
Weight	kg	33	40

VIEW A - Brushes holder

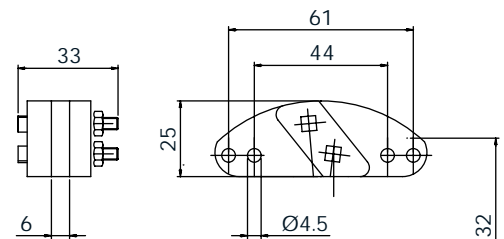

BCR250

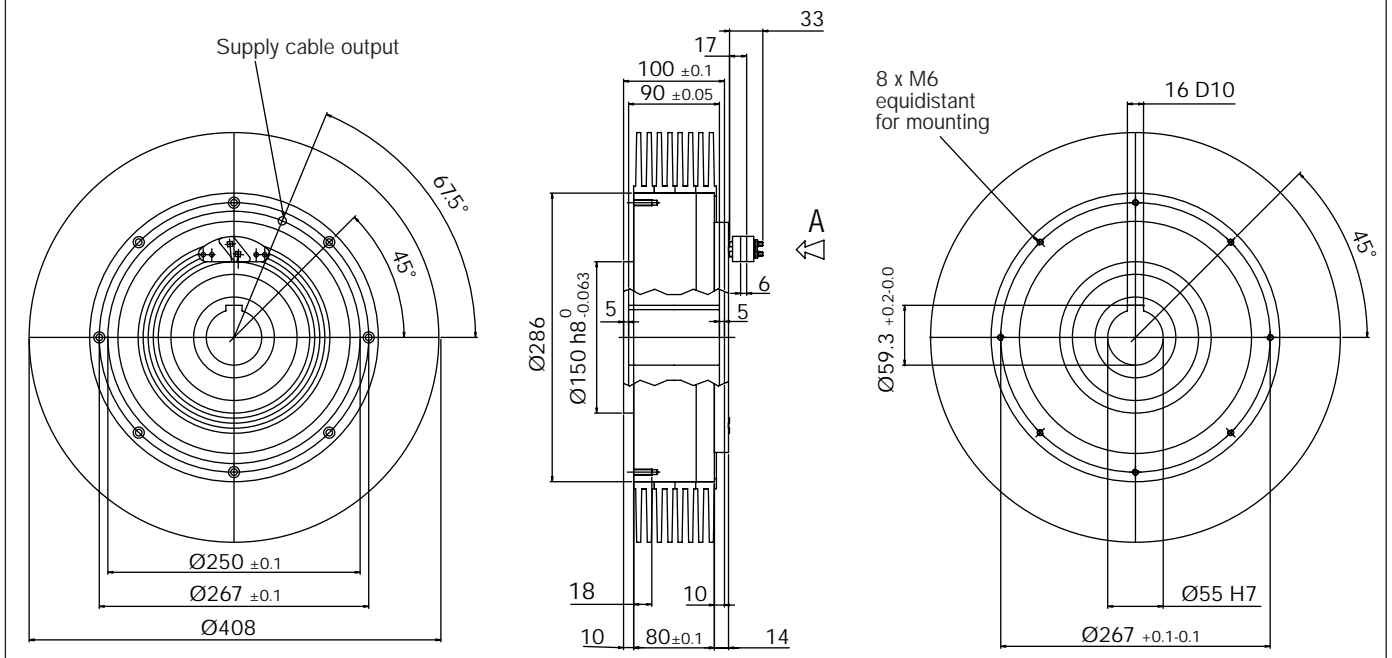

Magnetic clutches and brakes

Precision Tork™ units provide constant torque independent of slip speed. They offer excellent overload and jam protection for all drive train components and also provide soft starts with zero slip when a preset torque is reached. Precision Tork permanent magnet clutches and brakes do not require maintenance and provide extremely long life.

Features and Benefits

Fast, precise torque adjustment

- Torque is set with a large knurled adjustment ring
- Infinite adjustability between minimum and maximum settings. This allows units to be fine tuned to your unique requirement.

Torque is constant with respect to speed

- By using the Precision Tork™ unit, you can solve almost any torque control problem
- Torque is extremely consistent and smooth at low, as well as high speeds

No external control or power source

- Simple to install
- Nothing to monitor
- Unaffected by power interruption or power fluctuation
- Safe to use

Dependable performance

- Smallest possible transition from static to dynamic torque
- Virtually eliminates the "stick-slip" phenomenon associated with friction devices
- Long life. The only wearing parts are the ball bearings
- Extremely accurate. Precision Tork™ units out-perform all other devices at low RPM

Versatile mounting: Easy to retrofit

- Clutches are available with hollow bores for mounting on motor shafts or jack shafts
- Bolt circles allow for fixed mounting, adding a pulley, or stub shaft adapters
- Brakes are available with solid shaft outputs

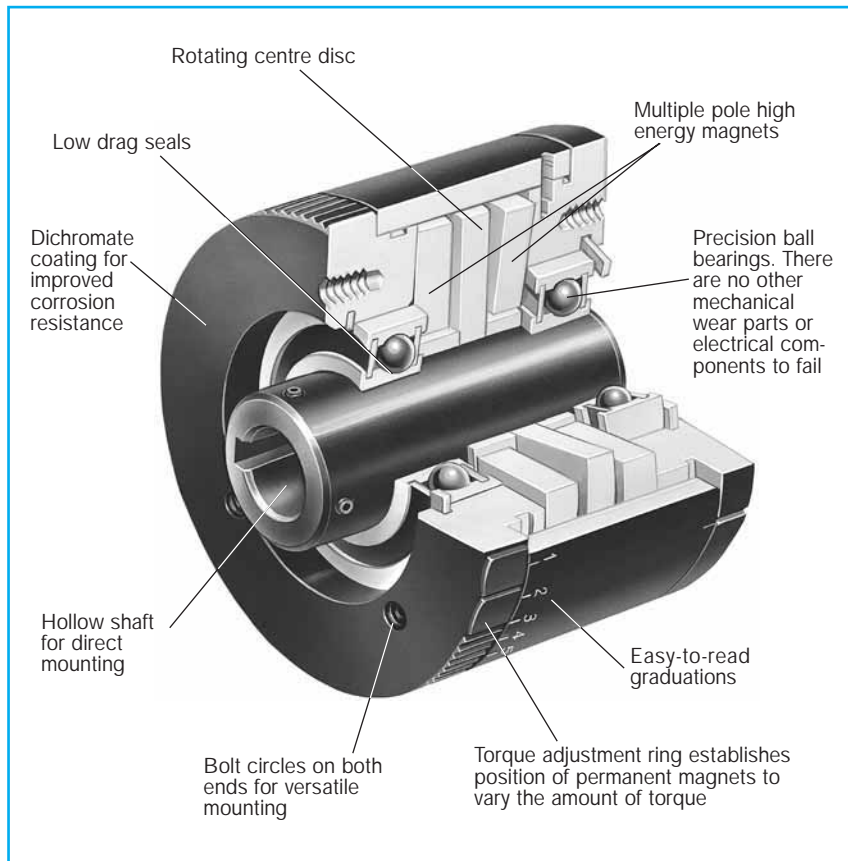

SPECIAL APPLICATIONS

Specials are our business. . .

- Special shaft bores and keyways
- Shaft extensions
- System retrofits
- Fixed torque units



Magnetic brakes - MB

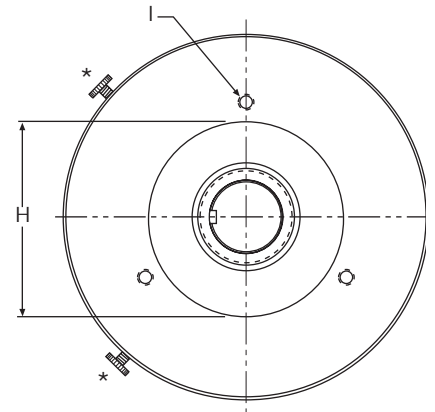
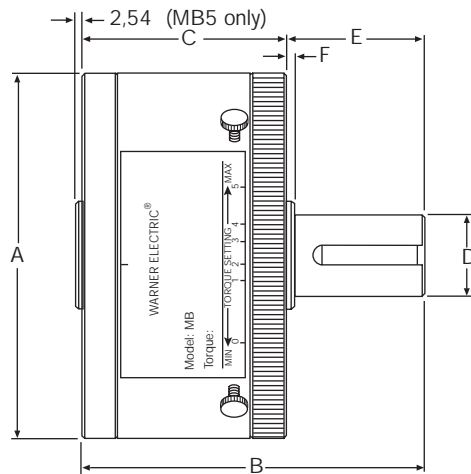

*Set screw adjustment

Drawing C

Specifications

Standard models	Stainless steel models	Max. torque (Nm)	Max. heat dissipation (W)	Inertia of output shaft (kgm ²)	Bending moment (Nm)	Max. speed (RPM)	Weight (kg)
MB1M-5	MB1MS-5	0,0078	3	$2,5 \times 10^{-7}$	0,11	3600	0,057
MB2M-6	MB2MS-6	0,16	10	$6,3 \times 10^{-6}$	0,56	3600	0,31
MB3M-8	MB3MS-8	0,68	18	$4,9 \times 10^{-5}$	1,13	1800	0,9
MB4M-14	MB4MS-14	1,24	22	$9,7 \times 10^{-5}$	1,13	1800	1,13
MB4M-15	MB4MS-15	1,24	22	$9,7 \times 10^{-5}$	1,13	1800	1,13
MB5M-19	MB5MS-19	3,4	72	$5,8 \times 10^{-4}$	2,82	1800	4,08
MB5M-24	MB5MS-24	3,4	72	$5,8 \times 10^{-4}$	2,82	1800	4,08
MB5.5M-19	MB5.5MS-19	5,6	110	$8,8 \times 10^{-4}$	2,82	1800	4,99
MB5.5M-24	MB5.5MS-24	5,6	110	$8,8 \times 10^{-4}$	2,82	1800	4,99
MB6M-19	MB6MS-19	7,9	150	$1,4 \times 10^{-3}$	2,82	1800	5,44
MB6M-24	MB6MS-24	7,9	150	$1,4 \times 10^{-3}$	2,82	1800	5,44
MB6DM-24	-	15,8	300	$2,5 \times 10^{-3}$	2,82	1800	11,37
MB9M-24	-	33,9	345	19×10^{-3}	5,65	1200	20,38

Dimensions (mm)

Models	Drawing	A	B	C	E	F	Pilot ø H
MB1M-5	C	25,1	34,8	21,59	13,2	-	10,01 - 10,06
MB2M-6	C	46,99	59,9	34,29	24,4	-	22,25 - 22,30
MB3M-8	C	69,6	76,71	50,2	26,5	0,76	35,08 - 35,13
MB4M-14	C	82,04	75,6	51,1	22,2	2,29	47,04 - 47,09
MB4M-15	C	82,04	75,6	51,1	22,2	2,29	47,04 - 47,09
MB5M-19	C	118,11	114	67	41,3	3,1	61,98 - 62,00
MB5M-24	C	118,11	114	67	41,3	3,1	61,98 - 62,00
MB5.5M-19	C	134,1	114,6	67,1	47,5	6,2	61,98 - 62,00
MB5.5M-24	C	134,1	114,6	67,1	47,5	6,2	61,98 - 62,00
MB6M-19	D	153,5	113,7	51,2	52,4	4,57	61,98 - 62,00
MB6M-24	D	153,5	113,7	51,2	52,4	4,57	61,98 - 62,00
MB6DM-24	**	**	**	**	**	**	82,50 - 82,55
MB9M-24	D	238,76	137,1	88,65	45,72	3,3	82,50 - 82,55

** Drawing on request

Magnetic brakes - MB

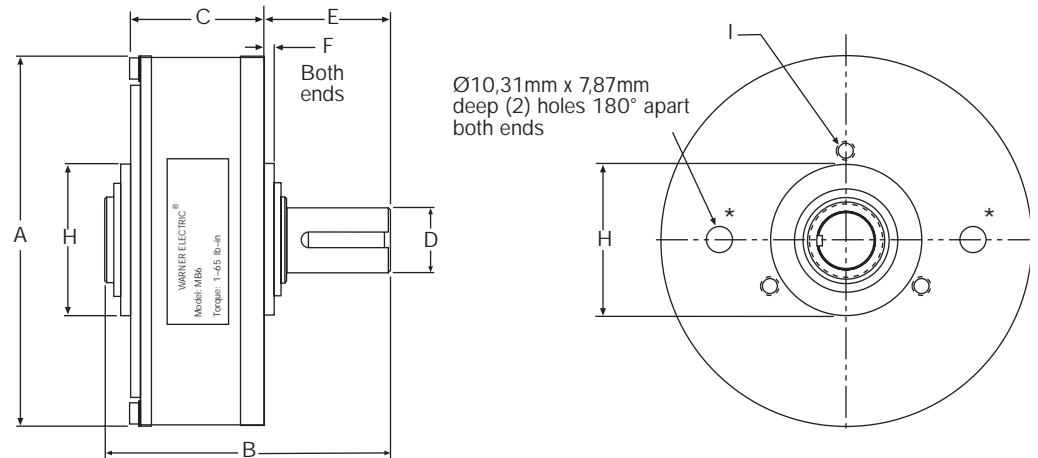

*Spanner wrench adjustment **Drawing D**

Dimensions (mm)

Models	Shaft ø D (h7)	Keyway - DIN 6885 Width x length)	Mounting (I)	Holes depth	Adjust screws
MB1M-5	5	4,5 Flat on 10,2	3 x M3 on ø 15,5 equidistant	6,4	M3
MB2M-6	6	5,5 Flat on 19	3 x M4 on ø 32 equidistant	8	M4
MB3M-8	8	7,5 Flat on 22,4	3 x M4 on ø 48 equidistant	11	M4
MB4M-14	14	5 x 19,3	3 x M5 on ø 60 equidistant	11	M4
MB4M-15	15	5 x 19,3	3 x M5 on ø 60 equidistant	11	M4
MB5M-19	19	6 x 25	3 x M6 on ø 80 equidistant	12,7	M5
MB5M-24	24	8 x 25	3 x M6 on ø 80 equidistant	12,7	M5
MB5.5M-19	19	6 x 25	3 x M6 on ø 100 equidistant	15,5	M5
MB5.5M-19	19	6 x 25	3 x M6 on ø 73,3 equidistant	12,7	M5
MB5.5M-24	24	8 x 25	3 x M6 on ø 100 equidistant	15,5	M5
MB5.5M-24	24	8 x 25	3 x M6 on ø 73,3 equidistant	12,7	M5
MB6M-19	19	6 x 25	3 x M6 on ø 100 equidistant	7,9	M5
MB6M-19	19	6 x 25	3 x M6 on ø 73,3 equidistant	7,9	M5
MB6M-24	24	8 x 25	3 x M6 on ø 100 equidistant	7,9	M5
MB6M-24	24	8 x 25	3 x M6 on ø 73,3 equidistant	7,9	M5
MB6DM-24	24	8 x 25	3 x M8 on ø 101,6 equidistant	13	Knob
MB9M-24	24	8 x 25	4 x M6 on ø 149,23 equidistant	12,7	M5
MB9M-24	24	8 x 25	3 x M6 on ø 107,95 equidistant	12,7	M5

Magnetic clutches - MC

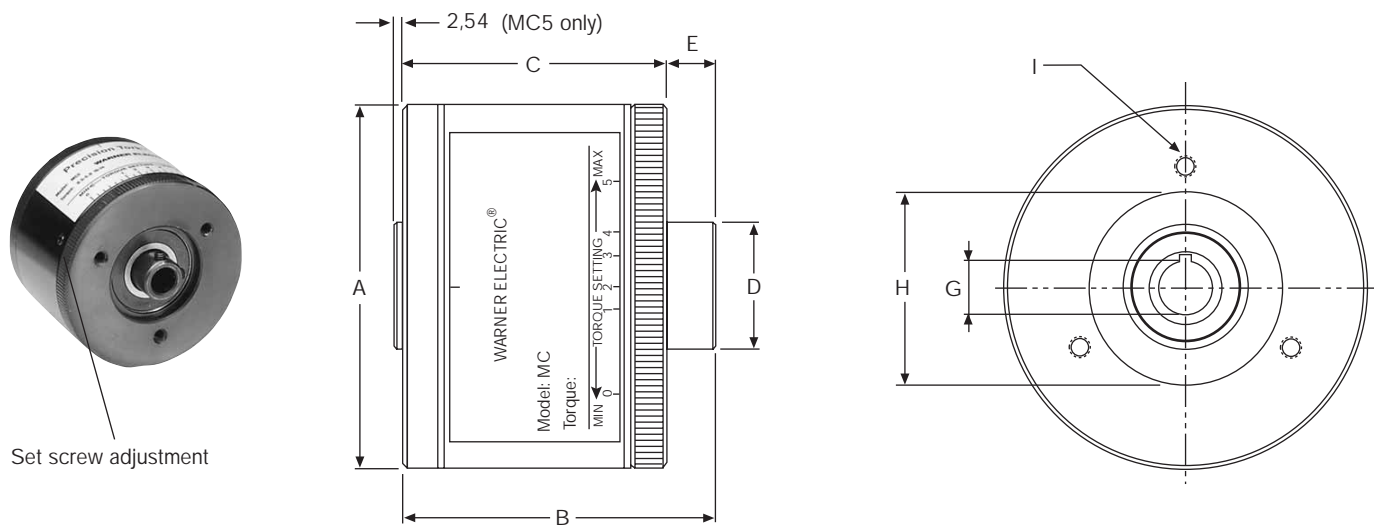

Drawing A

Specifications

Standard models	Stainless steel models	Max. torque (Nm)	Max. heat dissipation (W)	Inertia of output shaft (kgcm ²)	Bending moment (Nm)	Max. speed (RPM)	Weight (kg)
MC2M-6	MC2MS-6	0,16	10	4,9 x 10 ⁻⁶	0,56	3600	0,31
MC3M-8	MC3MS-8	0,68	18	4,6 x 10 ⁻⁵	1,1	1800	0,9
MC4M-8	MC4MS-8	1,24	22	9,4 x 10 ⁻⁵	1,1	1800	1,13
MC4M-14	MC4MS-14	1,24	22	9,4 x 10 ⁻⁵	1,1	1800	1,13
MC4M-15	MC4MS-15	1,24	22	9,4 x 10 ⁻⁵	1,1	1800	1,13
MC4M-16	MC4MS-16	1,24	22	9,4 x 10 ⁻⁵	1,1	1800	1,13
MC4M-001	MC4MS-001	2	22	1,7 x 10 ⁻⁴	1,1	1800	1,58
MC5M-16	MC5MS-16	3,4	72	5,4 x 10 ⁻⁴	2,82	1800	4,08
MC5M-19	MC5MS-19	3,4	72	5,4 x 10 ⁻⁴	2,82	1800	4,08
MC5,5M-16	MC5,5MS-16	5,6	110	8,5 x 10 ⁻⁴	2,82	1800	4,99
MC5,5M-19	MC5,5MS-19	5,6	110	8,5 x 10 ⁻⁴	2,82	1800	4,99
MC6M-16	MC6MS-16	7,9	150	1,4 x 10 ⁻³	2,82	1800	5,44
MC6M-19	MC6MS-19	7,9	150	1,4 x 10 ⁻³	2,82	1800	5,44
MC6DM-19	-	15,8	300	2,5 x 10 ⁻³	2,82	1800	10,84
MC9M-24	-	33,9	345	19 x 10 ⁻³	5,65	1200	20,38

Dimensions (mm)

Models	Drawing	A	B	C	D	E	F	Pilot ø H
MC2M-6	A	46,99	41,1	34,29	9,4	6,8	-	22,25 - 22,30
MC3M-8	A	69,6	56,3	50,2	14,99	6,1	-	35,08 - 35,13
MC4M-8	A	82,04	57,7	51,1	24,99	6,6	-	47,04 - 47,09
MC4M-14	A	82,04	57,7	51,1	24,99	6,6	-	47,04 - 47,09
MC4M-15	A	82,04	57,7	51,1	24,99	6,6	-	47,04 - 47,09
MC4M-16	A	82,04	57,7	51,1	24,99	6,6	-	47,04 - 47,09
MC4M-001	A	82,04	61,95	55,32	24,99	6,6	-	47,04 - 47,09
MC5M-16	A	118,11	80,77	67	35	13,8	-	61,98 - 62,00
MC5M-19	A	118,11	80,77	67	35	13,8	-	61,98 - 62,00
MC5,5M-16	A	134,1	81,7	67,1	35	14,6	-	61,98 - 62,00
MC5,5M-19	A	134,1	81,7	67,1	35	14,6	-	61,98 - 62,00
MC6M-16	B	153,5	80,77	51,82	34,6	19,5	4,57	61,98 - 62,00
MC6M-19	B	153,5	80,77	51,82	35	19,5	4,57	61,98 - 62,00
MC6DM-19	*	*	*	*	*	*	*	82,50 - 82,55
MC9M-24	B	238,76	106,2	88,65	44,8	13,97	3,3	82,50 - 82,55

* Drawing on request

Magnetic clutches - MC

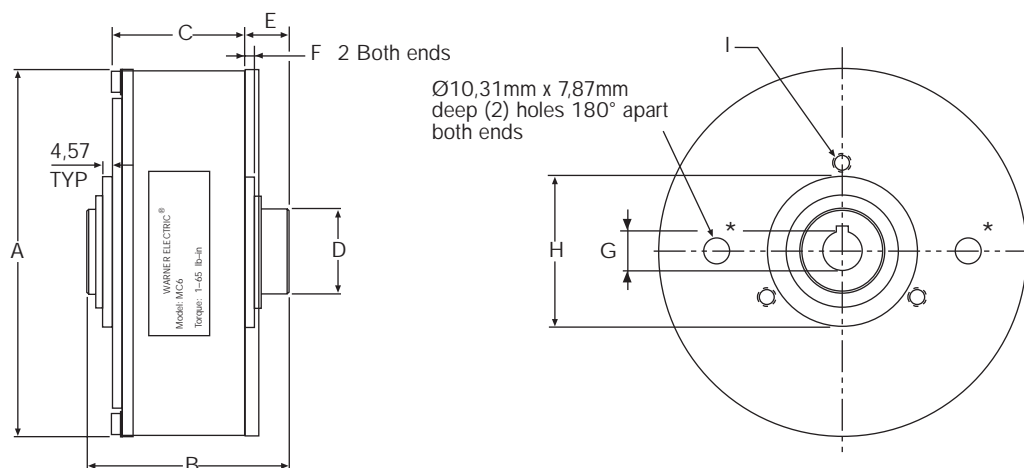

*Spanner wrench adjustment **Drawing B**

Dimensions (mm)

Models	Bore \varnothing G (H8)	Keyway (Width) - DIN 6885	Mounting (I)	Holes depth	Adjust screws
MC2M-6	6	Roll pin \varnothing 3 mm	3 x M4 on \varnothing 32 equidistant	8	M3
MC3M-8	8	2 x M4 90°	3 x M4 on \varnothing 48 equidistant	11	M4
MC4M-8	8	7,5 Flat	3 x M5 on \varnothing 60,33 equidistant	11	M4
MC4M-14	14	3	3 x M5 on \varnothing 60,33 equidistant	11	M4
MC4M-15	15	5	3 x M5 on \varnothing 60,33 equidistant	11	M4
MC4M-16	16	5	3 x M4 on \varnothing 60 equidistant	11	M4
MC4M-001	16	5	3 x M5 on \varnothing 60 equidistant	11	M4
MC5M-16	16	5	3 x M6 on \varnothing 80 equidistant	12,7	M5
MC5M-19	19	6	3 x M6 on \varnothing 80 equidistant	12,7	M5
MC5,5M-16	16	5	3 x M6 on \varnothing 100 equidistant	15,5	M5
	16	5	3 x M6 on \varnothing 73,03 equidistant	12,7	M5
MC5,5M-19	19	6	3 x M6 on \varnothing 100 equidistant	15,5	M5
	19	6	3 x M6 on \varnothing 73,03 equidistant	12,7	M5
MC6M-16	16	5	3 x M6 on \varnothing 100 equidistant	7,9	M5
	16	5	3 x M6 on \varnothing 73,03 equidistant	7,9	M5
MC6M-19	19	6	3 x M6 on \varnothing 100 equidistant	7,9	M5
	19	6	3 x M6 on \varnothing 73,03 equidistant	7,9	M5
MC6DM-19	19	6	3 x M8 on \varnothing 101,6 equidistant	13	M6
MC9M-24	24	8	4 x M6 on \varnothing 149,23 equidistant	12,7	M5
	24	8	3 x M6 on \varnothing 107,95 equidistant	12,7	M5

Typical mounting

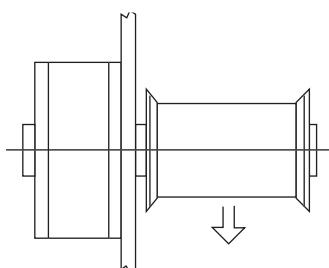

Brake

Typical setup for tensioning wire, film and fibers.

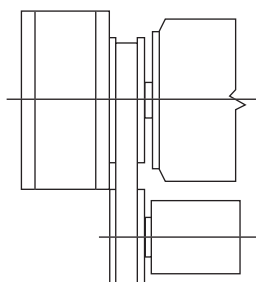

Clutch

Typical setup for material handling, soft starts and torque limiting.

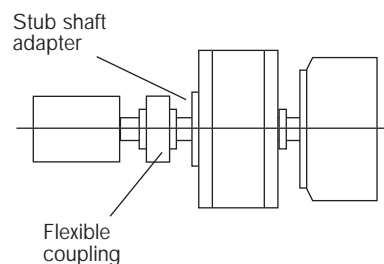

Clutch coupling

Typical setup for torque limiting protection used for labeling, capping and printing applications.

Magnetic clutches and brakes

Heat Dissipation Charts

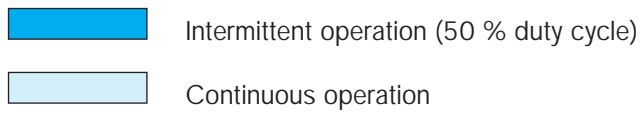

MB1

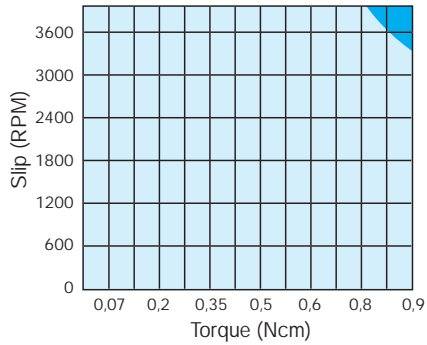

MC1.5/MB1.5

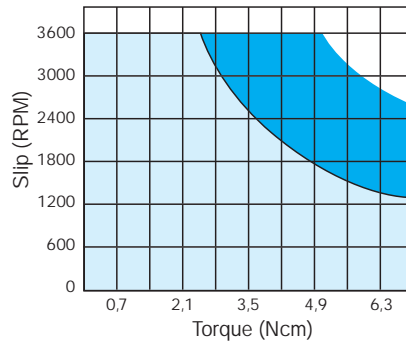

MC2/MB2

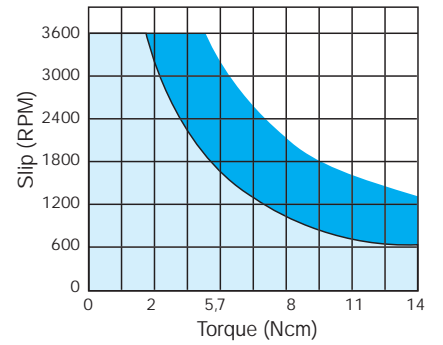

MC3/MB3

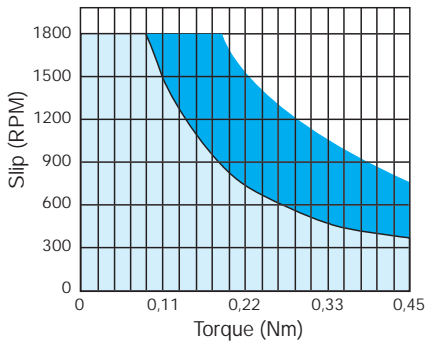

MC4/MB4

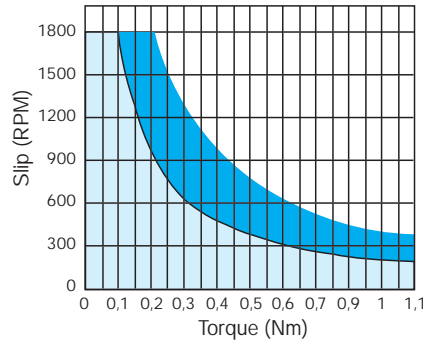

MC5/MB5

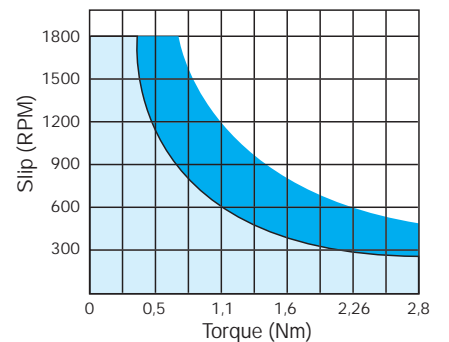

MC5.5/MB5.5

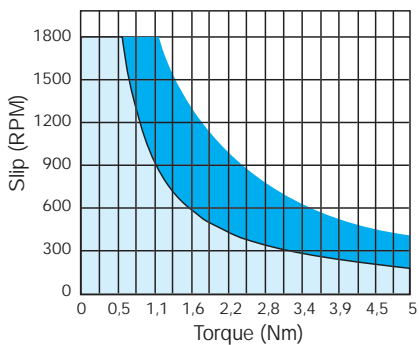

MC6/MB6

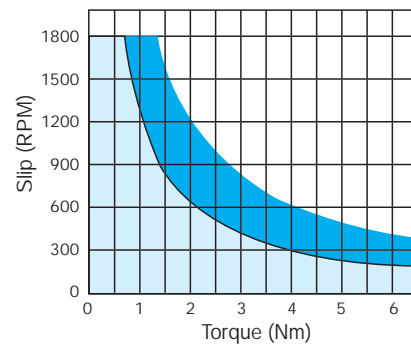

MC9/MB9

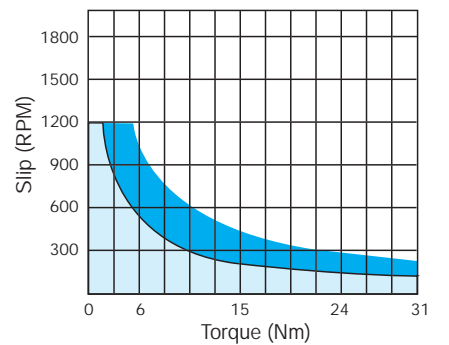

Magnetic clutches and brakes

Torque Setting Charts

MB1

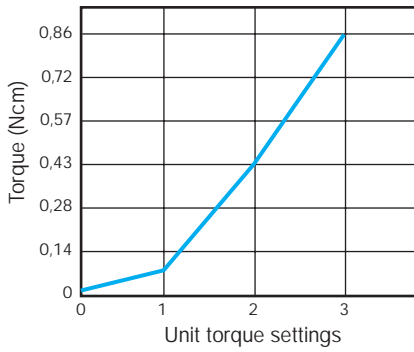

MC2/MB2

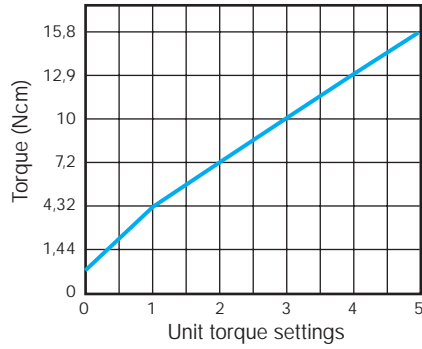

MC3/MB3

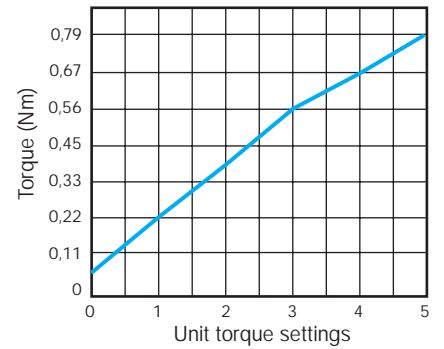

MC4/MB4

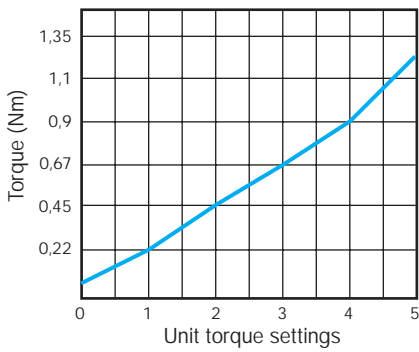

MC5/MB5

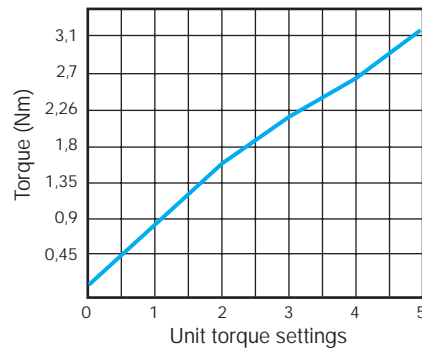

MC5.5/MB5.5

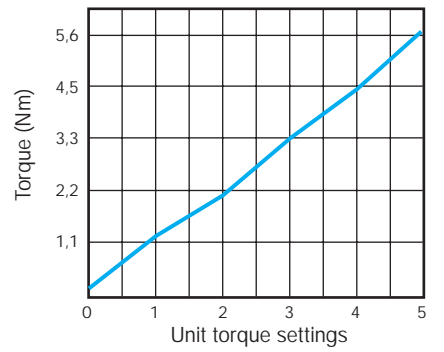

MC6/MB6

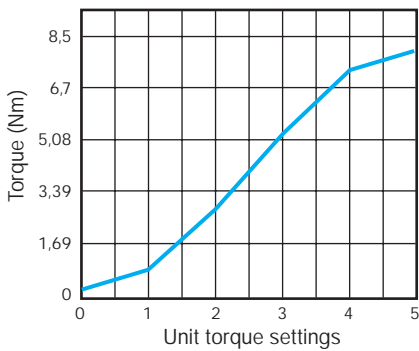

MC9/MB9

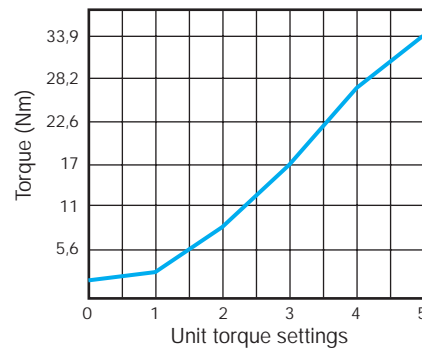

Applications

Unwind tension control

Brake mounted on shaft of unwinds spool or bobbin

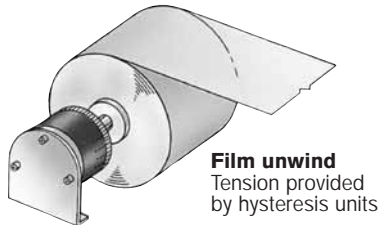

Information required:

Full roll \varnothing (m) = 0,15
 \varnothing core (m) = 0,1
 Average tension (N) = 18
 Velocity (m/mn) = 30

How to size:

Average radius = (Full roll \varnothing + core \varnothing) / 4 = (0,15 + 0,1) / 4 = 0,06 m

Average tension (Nm) =

Average tension · Average radius =
 18 · 0,06 = 1,08 Nm

Check tension range:

Max. tension =
 Torque · 2 / core \varnothing =
 1,08 · 2 / 0,1 = 21,6 N

Min. tension =
 Torque · 2 / full roll \varnothing =
 1,08 · 2 / 0,15 = 14,4 N

Slip watts (watt) =

(Max. tension · velocity) / 60 =
 (21,6 · 30) / 60 = 10,8 watts

Select **MB4 Model**

Cycling application

Bottle capping

Constant torque provided by a hysteresis clutch

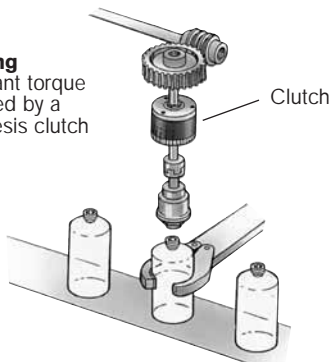

Information required:

Slip = 500 tr/mn
 Torque = 0,90 Nm
 % slip time of total cycle time = 25%

Select an **MC4 Model** from the specification chart.

* Consult factory if peak slip watts are extremely high or if duration of slip period is in excess of 1 minute

How to size:

$$*Watts = \frac{\text{Torque} \cdot \text{slip}}{9,55} \cdot 0,25 = \frac{500 \cdot 0,9}{9,55} \cdot 0,25 = 11,8 \text{ watts}$$

Nip roll or pulley tension control

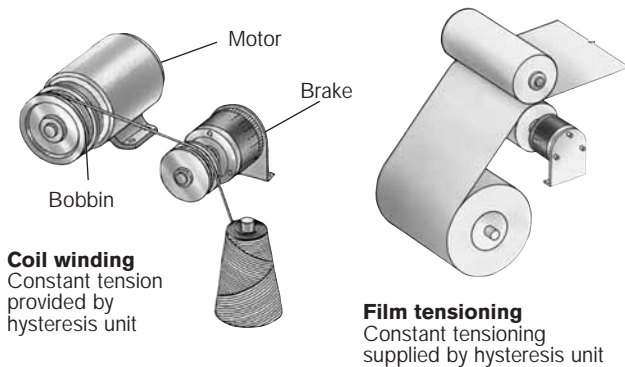

Information required:

Pulley or nip roll diameter = 0,1 m
 Tension = 26 N
 Velocity = 30 m/mn

How to size:

Torque = Tension · \varnothing / 2 = 26 · 0,1 / 2 = 1,3 Nm

Slip watts = (max. tension · velocity) / 60
 = (26 · 30) / 60 = 13 watts

Select **MB5 Model**

Overload protection / Torque limiting / Soft start

Motor horsepower method

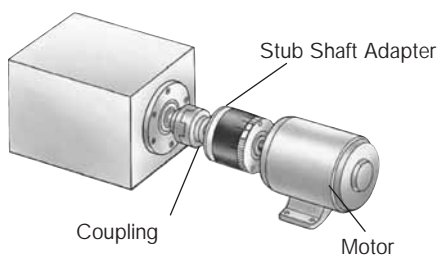

Torque limiting

Hysteresis clutch provides overload protection

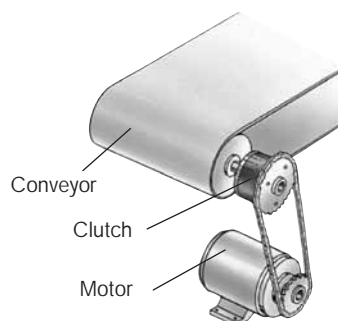

Material handling

Hysteresis clutch can provide overload protection and soft start

Information required:

Power motor = 0,37 kw
 Speed motor = 1750 RPM

How to size:

Torque = 9550 · kw / N =
 9550 · 0,37 / 1750 = 2 Nm

Select an **MC5 Model** from the specification chart.

Tension selection

The **WARNER ELECTRIC** experience enables us to offer a tension guide as shown below. For any special material not included in the chart below, please consult **WARNER ELECTRIC**. These values are usual values for information only, please check exact tension you need in your application.

PAPER WEIGHT *

$$F = f \times \text{width [cm]}$$

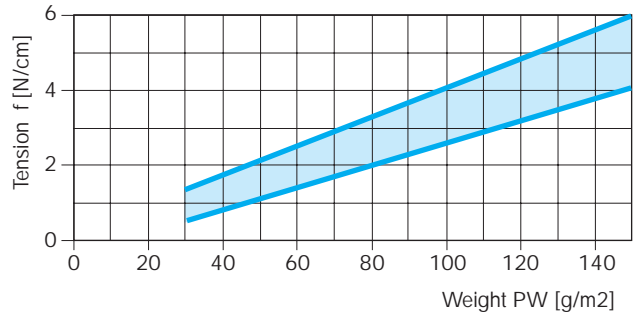

FOIL*

$$F = f \times \text{width [cm]}$$

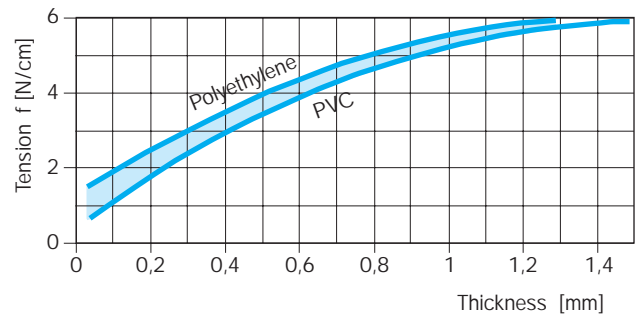

WIRE *

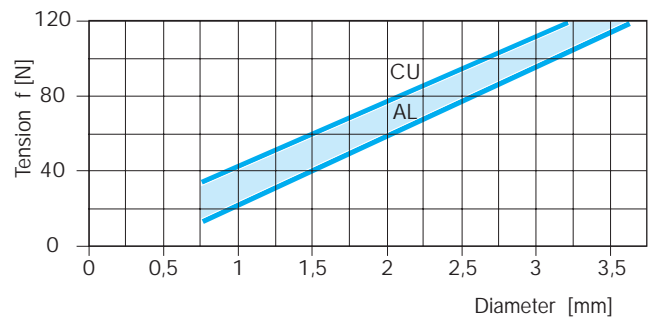

* Usual values for information only.

MATERIAL DENSITY

	kg/m ³
Paper	920
Paper board	1420
Alu foil	2720
Alu wire	2750
Copper	8550
PVC	400-1050

Data application form

To enable us to assist you in selecting the best product type and specification to ensure reliable and accurate tension control, please submit this **APPLICATION FORM**.

Company/Contact name: _____ Tel. _____ Fax: _____

Address: _____ e mail: _____

City: _____ Country: _____ Date: _____ Business: _____

MAX. ROLL DIAMETER : _____ m MASS: _____ kg

MIN. ROLL DIAMETER : _____ m

LINE SPEED : _____ m/mn

BRAKE RATIO : _____ $i = z2/z1$ (Brake on roll axis $i = 1$)

FIRST CASE : unwind tension known

TENSION FORCE ON TOTAL WEB WIDTH : _____ N max. _____ N min.

SECOND CASE : unwind tension unknown

If unknown precise type of material :

CURRENT VALUES USED :

ALUMINIUM FOIL : 00,7 N/cm / thickness micron
 CELLOPHANE : 0,05 N/cm/ thickness micron
 ACETATE : 0,035 N/cm / thickness micron
 MYLAR (POLYESTER) : 0,505 N/cm / thickness micron
 POLYETHYLENE : 0,017 N/cm / thickness micron
 POLYPROPYLENE: 0,017 N/cm / thickness micron
 POLYSTIRENE : 0,06 N/cm /thickness micron
 SARAN : 0,008 N/cm / thickness micron
 VINYL : 0,01 N/cm / thickness micron

PAPER		PAPER	
10 gr/m ²	0,5 N/cm	130 gr/m ²	3,1 N/cm
25 gr/m ²	0,7 N/cm	150 gr/m ²	3,8 N/cm
40 gr/m ²	1 N/cm	200 gr/m ²	5,5 N/cm
60 gr/m ²	1,5 N/cm	250 gr/m ²	7,7 N/cm
80 gr/m ²	2 N/cm	330 gr/m ²	11,5 N/cm
100 gr/m ²	2,5 N/cm	400 gr/m ²	14,8 N/cm

VALUE PER CENTIMETER WIDTH : _____ N/cm / micron

NUMBER OF MICRON MATERIAL THICKNESS : _____ (Paper note 1)

TENSION FORCE BY CENTIMETER WIDTH : _____ N max. _____ N min.

ROLL WIDTH : _____ cm max. _____ cm min.

TOTAL FORCE ON ROLL WIDTH : _____ N _____ N min.

MAX. ROLL SPEED : _____ RPM

MIN. ROLL SPEED : _____ RPM

THEORIC BRAKE TORQUE : _____ Nm max. _____ Nm min.

SLIDDING TORQUE : _____ Nm

REQUIRED BRAKE TORQUE : _____ Nm max. _____ Nm min.

TOTAL HEAT DISSIPATION : _____ kW

REQUIRED BRAKE SIZE :

NUMBER OF BRAKE PER ROLL : _____

REQUIRED TENSION CONTROL REGULATION :

Data application form

START - STOP :

t1 = MACHINE STARTING TIME _____ secondes

t2 = ROLL ACCELERATING TIME _____ secondes

t3 = MACHINE DECELERATING TIME _____ secondes

t4 = BRAKE ACCELERATING TIME _____ secondes

MB (see catalogue MTB-II or TB) or stopping brake applied _____ Nm

ACCELERATION TIME = $t_2 = m \cdot v / 120 \cdot F$ _____ secondes

(force must accelerate the roll)

Storage length = $l = v / 120 \cdot (t_2 - t_1)$ _____ metres

(if machine is accelerating faster : $t_1 < t_2$)

If the dancer load is a mass, _____ Newtons

the tension force will increase = $F' = F \cdot v / 118 \cdot t_1$

or

If the dancer load is a mass, _____ Newtons

the tension force will increase = $F' = F \cdot v / 118 \cdot t_2$

DECELERATION :

1) Maintaining the web force, (warning : exact values if MB or t3 defined) :

Braking torque = $MB = (m \cdot D \cdot v / 240 \cdot t_4) + F \cdot D / 2) \cdot 1/i$ _____ Nm 0 if MB not defined

Time t4 = $m \cdot D \cdot v / 240 \cdot (MB \cdot i - F \cdot D / 2)$ _____ secondes 0 if MB not defined

If $t_4 > t_3$ necessary length = $l = v \cdot (t_4 - t_3) / 120$ _____ metres 0 if t3 not defined

2) Uncontrolled emergency stop :

Emergency stopping time = $t = m \cdot D \cdot v / 240 \cdot MB \cdot i$ _____ secondes

Material length spillage = $l = v \cdot t / 120$ _____ metres

ALTRA INDUSTRIAL MOTION

Altra Industrial Motion

Altra Industrial Motion, Inc.
14 Hayward Street
Quincy, MA 02171, U.S.A.
Tel. +01 (617) 328 3300, Fax +01 (617) 689 6202

EUROPE

FRANCE

WARNER ELECTRIC EUROPE
Siège social et usine
7, rue Champfleury, BP 20095
F-49182 St Barthélemy d'Anjou Cedex
Tel. +33 (0)2 41 21 24 24, Fax +33 (0)2 41 21 24 00
e-mail: sales.dept@warnerelectric-eu.com

ASIA

HONG KONG + P.R. CHINA

WARNER - SHUI HING Ltd
Unit 4A, 3rd Floor
Join-In Hang Sing Centre
71-75 Container Port Road
Kwai Chung, Hong Kong
Tel. +852 2615 9313, Fax +852 2615 9162

INDIA

M/s. FRANCIS KLEIN & Co. Pvt. Ltd.
70/1, Mission Road
IND - Bangalore 560 027
Tel. +91 802 272781, Fax +91 802 276324

KOREA + SINGAPORE

WARNER ELECTRIC SINGAPORE
30 Pioneer Road
Singapore 628502
Tel. +65 487 4464, Fax +65 487 6674

TAIWAN

WARNER ELECTRIC Ltd
3rd Fl., No. 35, Lane 32
Kwang-Fu South Road
105 Taipei, TAIWAN R.O.
Tel. +886 2 2577 8156, Fax +886 2 2570 6358

THAILAND

WARNER ELECTRIC Co. Ltd
199/19 Soi Anamai
Srinakharin Rd. Prawes
Bangkok 10250, Thailand
Tel. +66 2 322 0481, Fax +66 2 320 2380

AMERICA

U.S.A.

WARNER ELECTRIC, Gardner Street 449
South Beloit, Illinois 61080 U.S.A.
Tel. +01 (815) 389 3771
Fax +01 (815) 389 2582

OCEANIA

AUSTRALIA

WARNER ELECTRIC AUSTRALIA
Unit 1/11, Packard Avenue
Castle Hill, N.S.W. 2154
Tel. +612 9894 0133, Fax +612 9894 0368

DISTRIBUTION

Most products are available through authorised local distributors, please contact your nearest WARNER office for information. Distributors are located in the following countries:

Argentina	Greece	Portugal
Austria	Holland	Scotland
Belgium	India	Slovakia
Brazil	Ireland	Slovenia
Croatia	Israel	South Africa
Bosnia	Italy	Spain
Czech Rep.	Lithuania	Sweden
Egypt	New Zealand	Switzerland
Finland	Norway	Turkey
France	Poland	U.S.A.

www.warnerelectric-eu.com



MC507r-gb-0607 - © 2007